

The Electric Force of a Current

A. K. T. Assis

University of Campinas – Brazil

www.ifc.unicamp.br/~assis

The Electric Force of a Current

A grayscale portrait of Heinrich Weber, a German physicist, wearing a dark suit, white shirt, and dark bow tie. He has long, wavy hair and is wearing glasses.

Weber and the surface charges of
resistive conductors carrying steady
currents

Andre Koch Torres Assis
and
Julio Akashi Hernandez

Assis and Hernandez,
The Electric Force of a Current
(Apeiron, Montreal, 2007)

www.ifi.unicamp.br/~assis

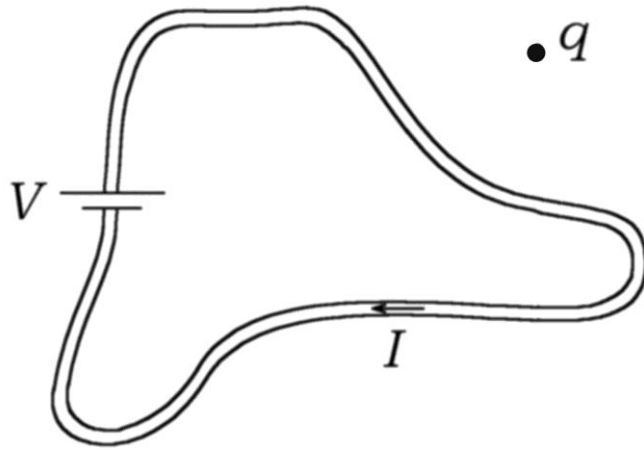

$$\vec{F} = ?$$

- Is there a force between a stationary charge and a stationary circuit carrying a steady current?
- Is the wire neutral at all points?
- Where are the charges which generate the electric field inside the resistive wire?

Maxwell (Treatise of Electricity and Magnetism, 1873, article 848):

“Such an action has never been observed.”

Clausius (1877): “We accept as criterion the experimental result that a constant current in a stationary conductor exerts no force on stationary charge.”

Feynman Lectures on Physics, Vol. 2, Section 13-6 (1964): “In a normal conductor, like copper, the electric currents come from the motion of some of the negative electrons. (...) There is thus no electric field outside the wire.”

Jackson, Classical Electrodynamics, 1975, Exc. 14.13: “For a real circuit the stationary positive ions in the conductor will produce an electric field which just cancels that due to the moving charges.”

There must be an electric field outside resistive wires carrying steady currents. Reasons:

Continuity of the tangential component of \vec{E}

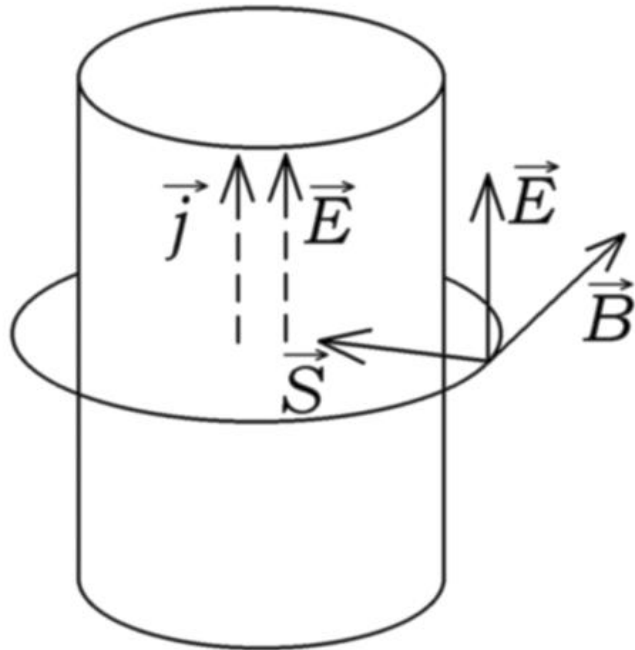

Where are the electric charges which generate the electric field inside a wire carrying a constant current?

Bending a wire:

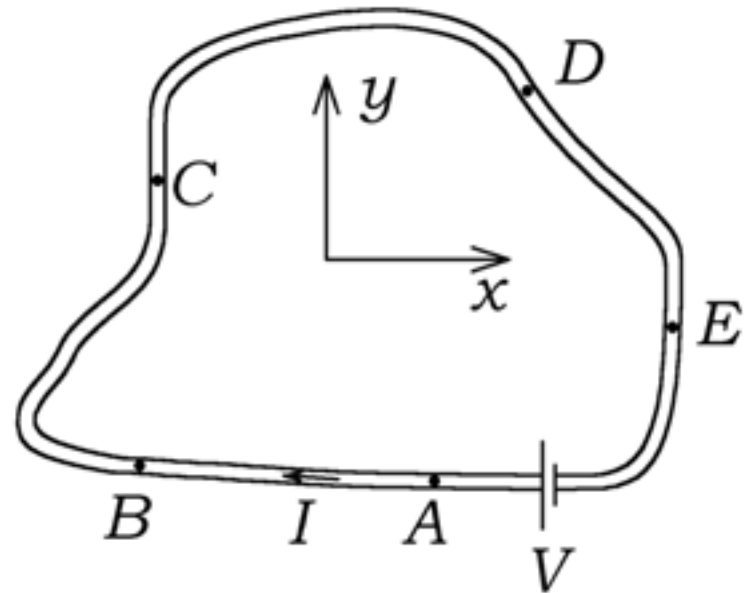
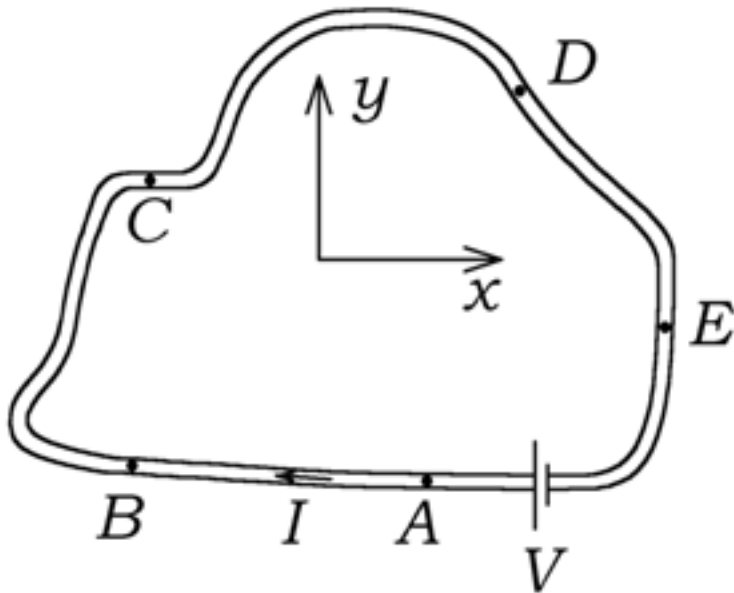

Ohm's law $\vec{E} = \rho \vec{J}$

Weber and Kirchhoff in 1850-7:

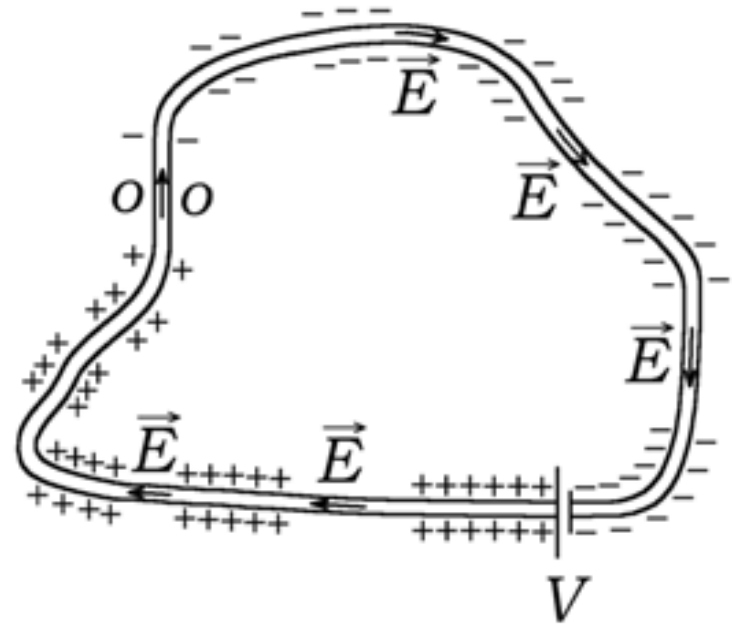
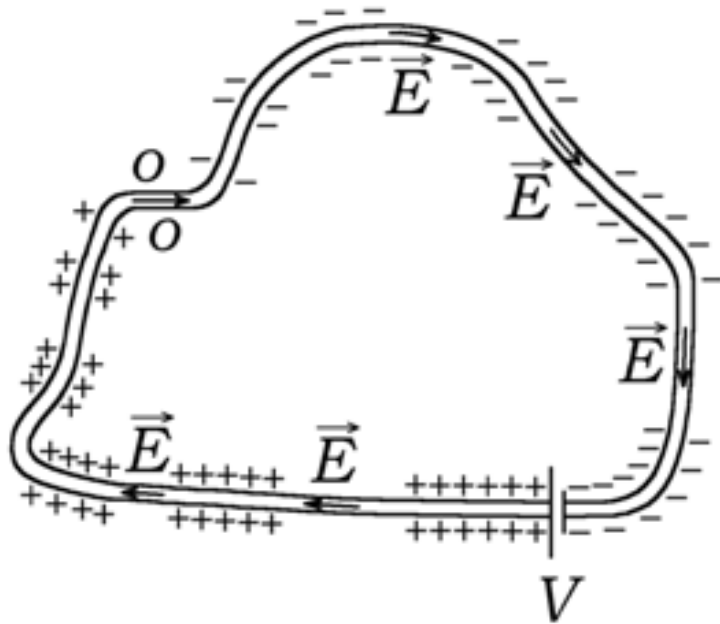

Consequences:

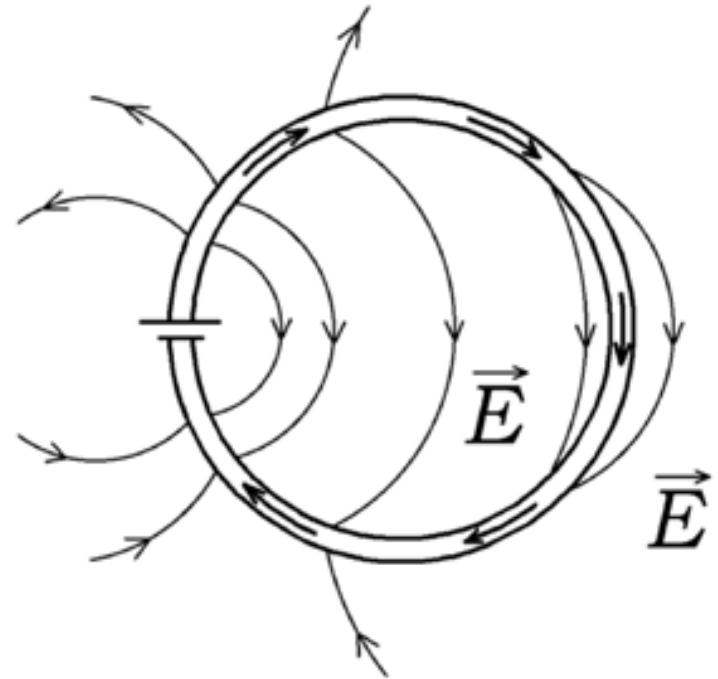
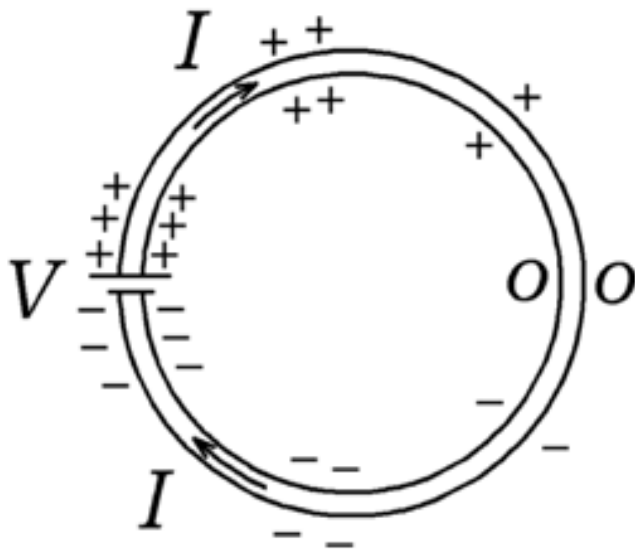

Solution of the problem:

$$\phi(\vec{r}) = \frac{1}{4\pi\epsilon_0} \frac{q'}{|\vec{r} - \vec{r}'|} = \frac{1}{4\pi\epsilon_0} \iint \frac{\sigma(\vec{r}') da'}{|\vec{r} - \vec{r}'|}$$

$$\nabla^2 \phi = 0$$

and the boundary conditions over the surface of the wire.

Straight wire with steady current:

$$\sigma = -\sigma_0 \frac{z}{a}$$

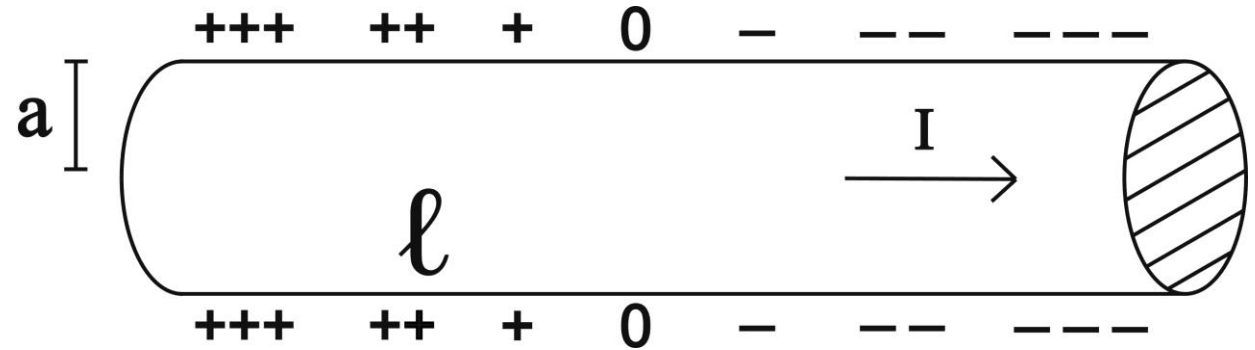

$$\vec{E}(\rho < a) = E_0 \hat{k}$$

$$\vec{E}(\rho > a) = \frac{E_0}{\ln \frac{l}{a}} \left(\ln \frac{l}{\rho} \hat{k} - \frac{z}{\rho} \hat{\rho} \right)$$

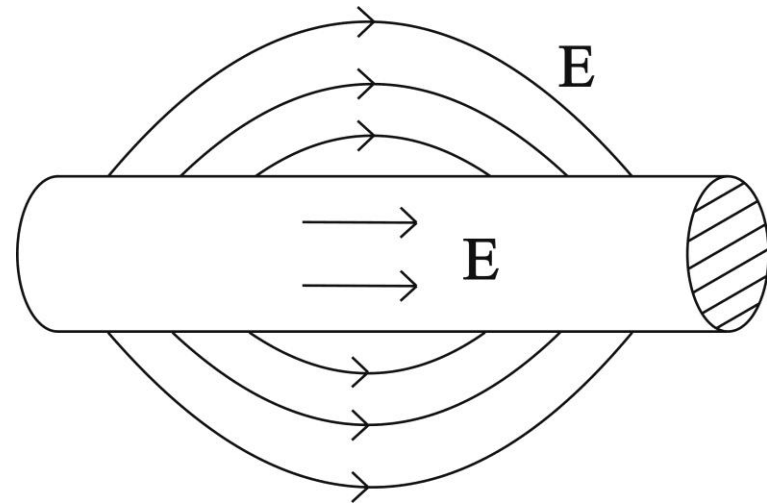

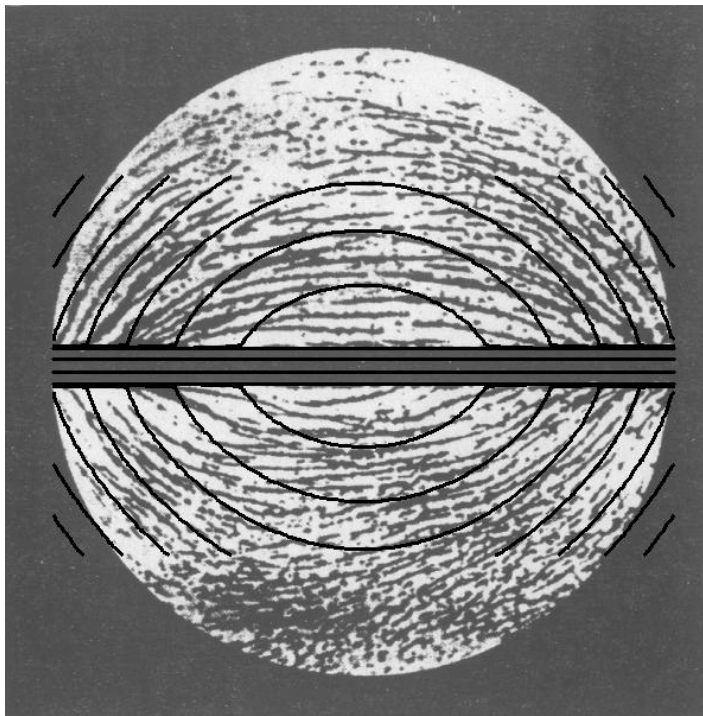

Bergmann and Schaefer
(Elektrizität und
Magnetismus, 1950).

$$\Delta V = 30 \text{ kV.}$$

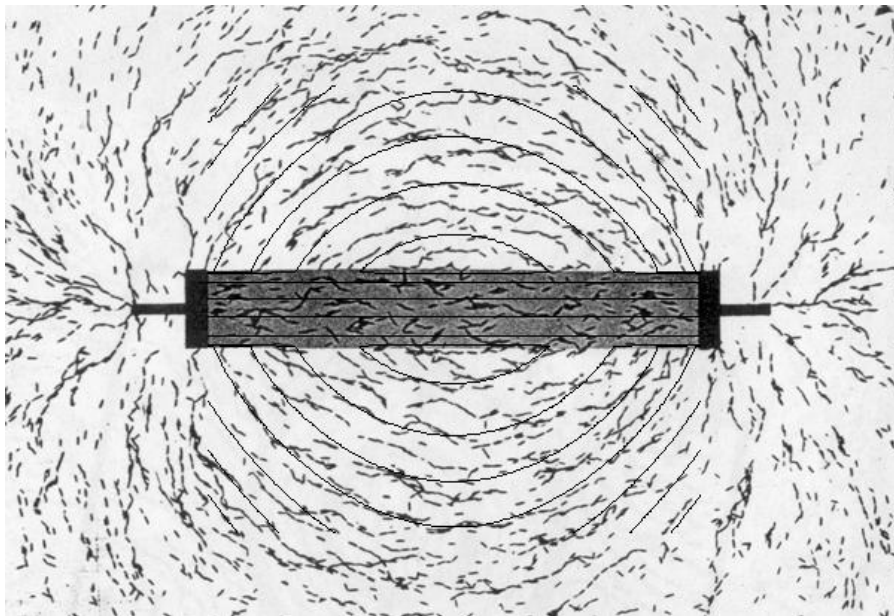

Jefimenko, AJP 30,
19 (1962).

$$\Delta V = 10 \text{ kV.}$$

Jefimenko et al., Proc. West Virginia Acad. Sci. 34, 163 (1962).

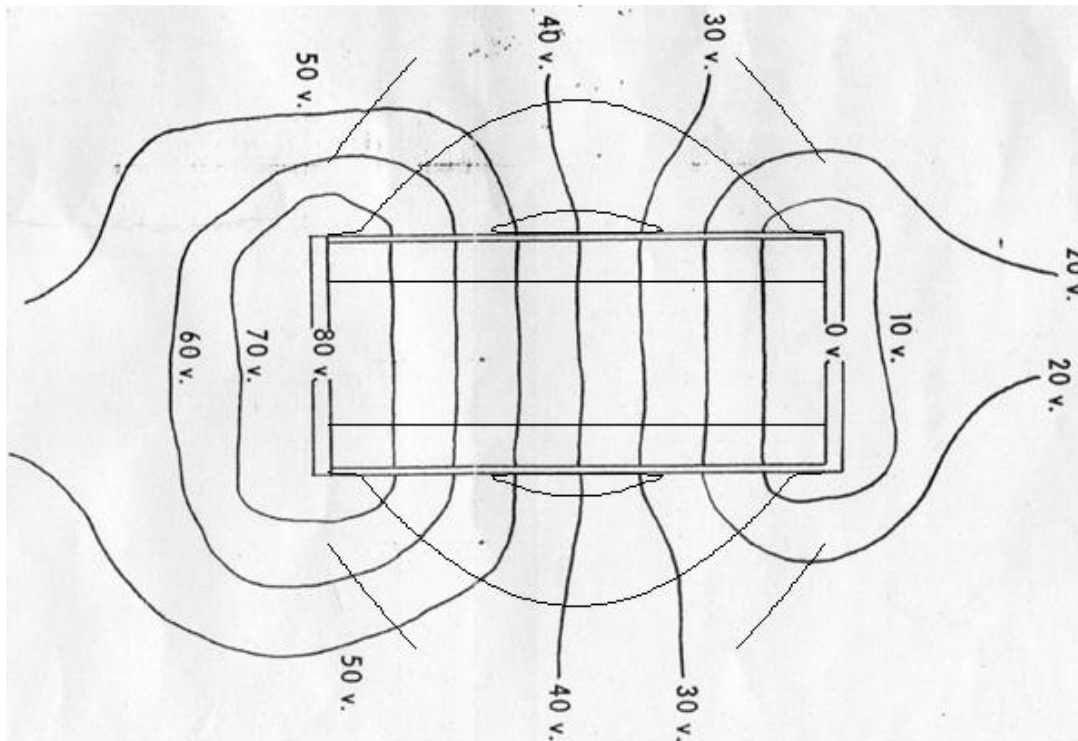

Transmission line:

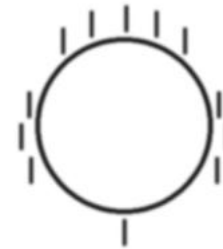
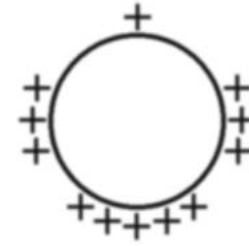
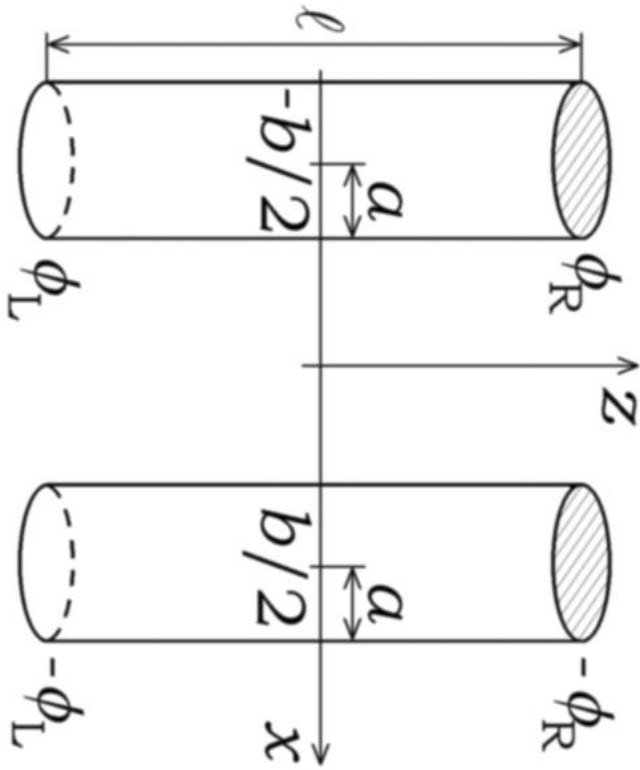

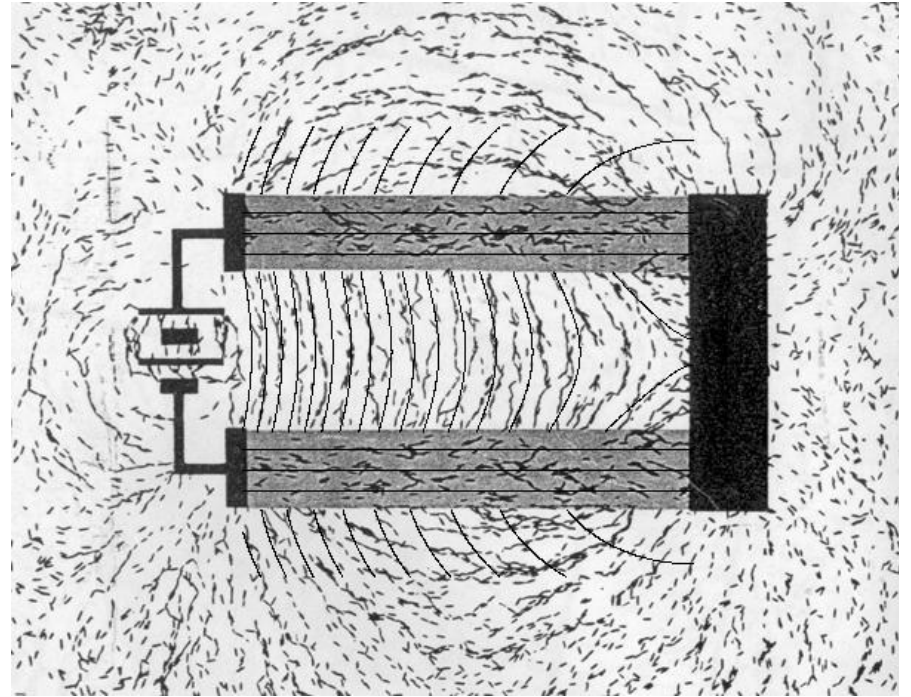
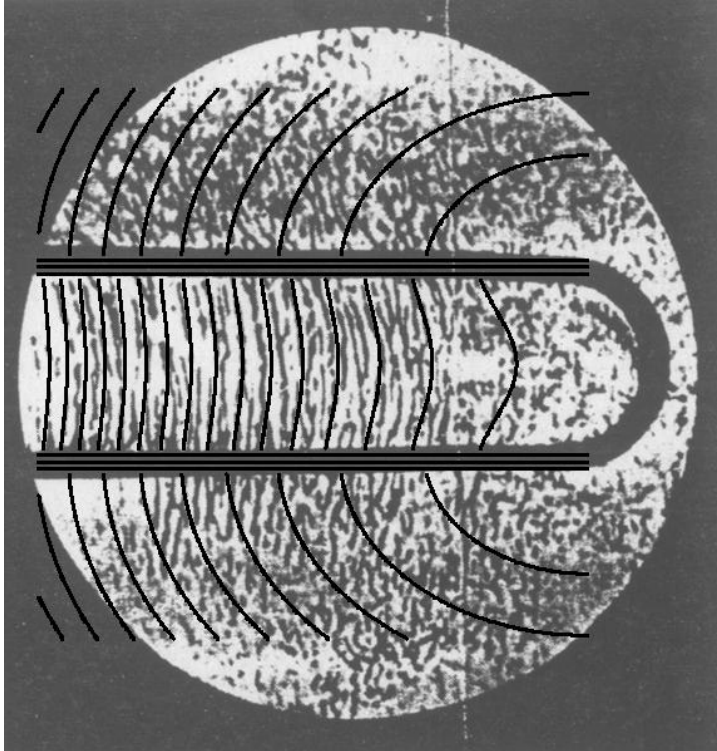

Coaxial cable: Analogous situation to that of a straight wire.

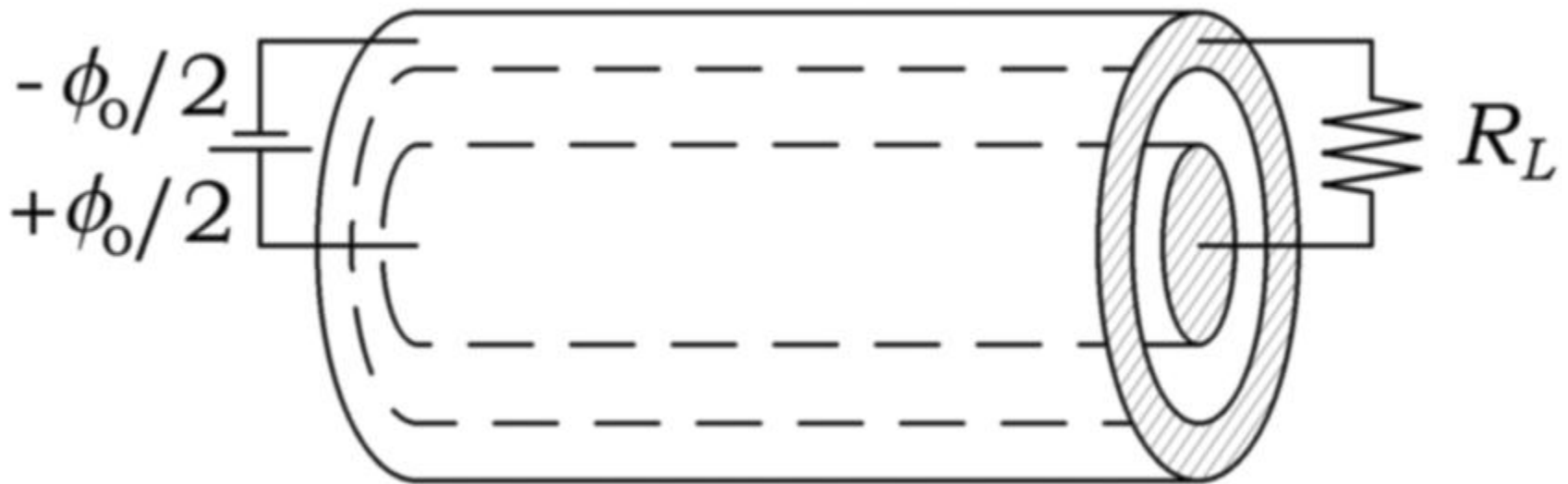

E outside $\neq 0$. There should be interference between two coaxial cables.

Infinite solenoid, Heald,
AJP 52, 522 (1984):

$$\sigma = \sigma_0 \tan \frac{\varphi}{2}$$

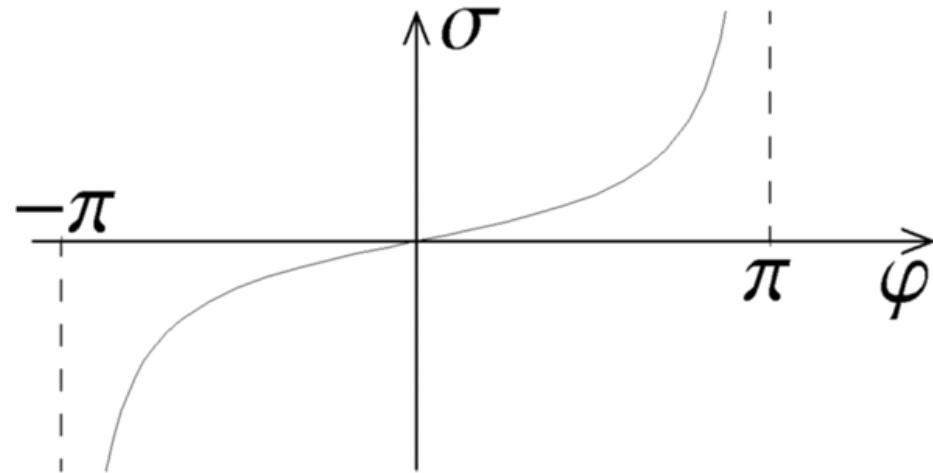
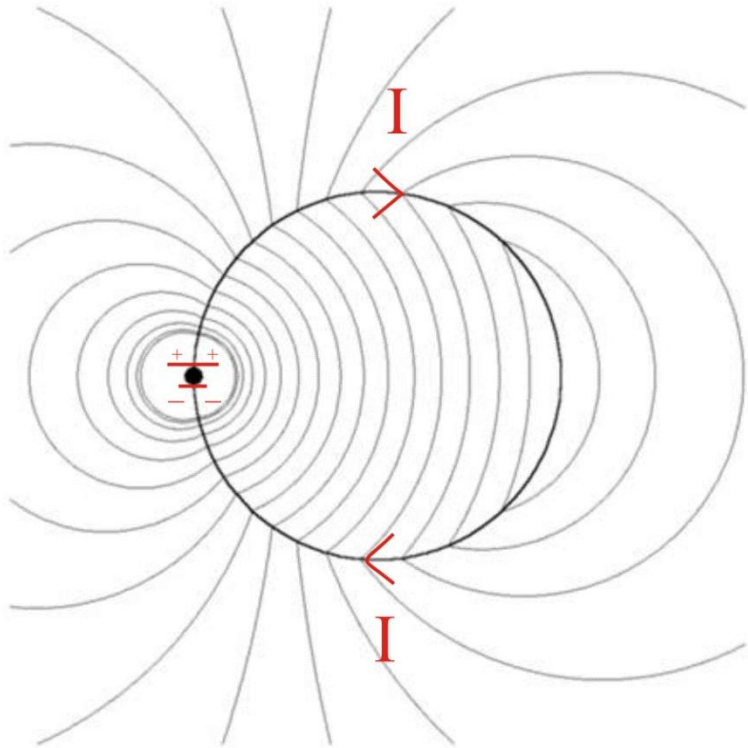

E outside $\neq 0$

Resistive ring with steady current

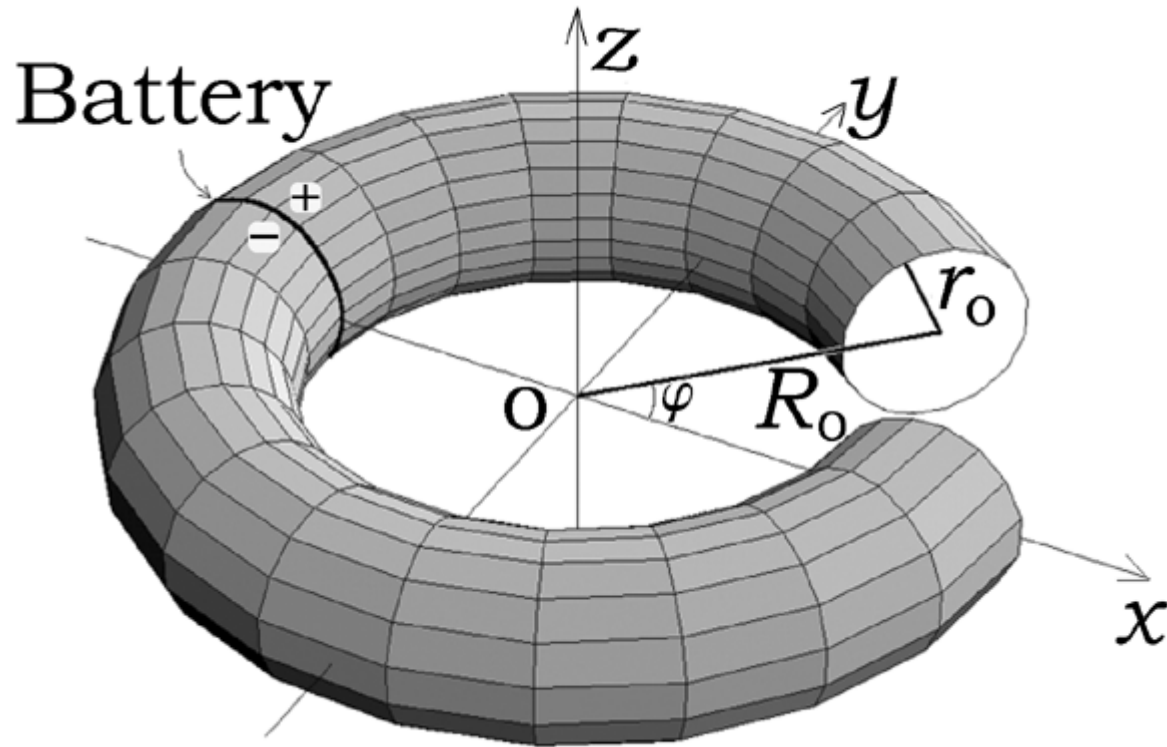

J. A. Hernandez and A. K. T. Assis,
Phys. Rev. E 68, 046611 (2003).

Toroidal coordinates $\approx, \mathfrak{M}, \mathfrak{E}$:

$$\tan \eta = \frac{2a\sqrt{x^2 + y^2}}{x^2 + y^2 + z^2 + a^2}, \quad \tan \chi = \frac{2za}{x^2 + y^2 + z^2 - a^2}, \quad \tan \varphi = \frac{y}{x}$$

$$\nabla^2 \phi = 0, \quad \phi = \sqrt{\cosh \eta - \cos \chi} H(\eta) X(\chi) \Phi(\varphi)$$

$$\phi = \sqrt{\cosh \eta - \cos \chi} \left\{ \sum_{p=0}^{\infty} A_p \cos(p\chi) P_{p-1/2}(\cosh \eta) \right. \\ \left. + \sum_{q=1}^{\infty} \sin(q\varphi) \left[\sum_{p=0}^{\infty} B_{pq} \cos(p\chi) P_{p-1/2}^q(\cosh \eta) \right] \right\}$$

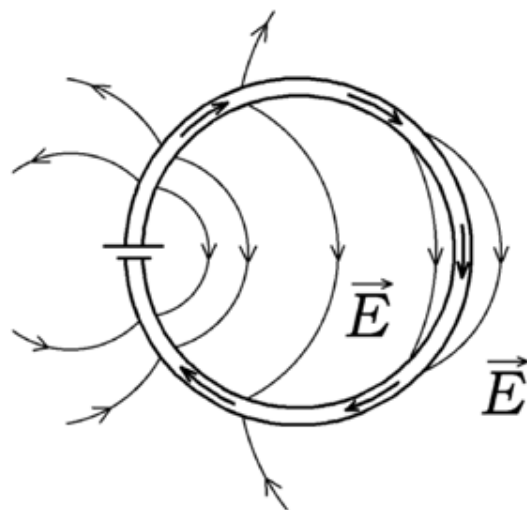
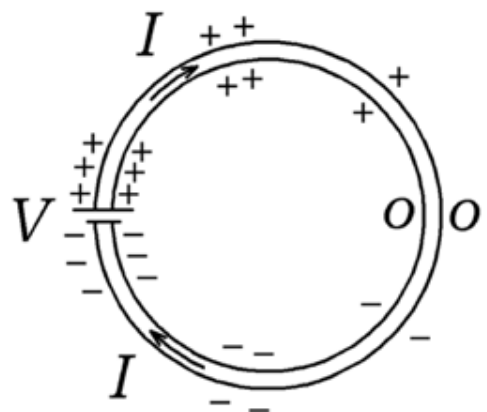
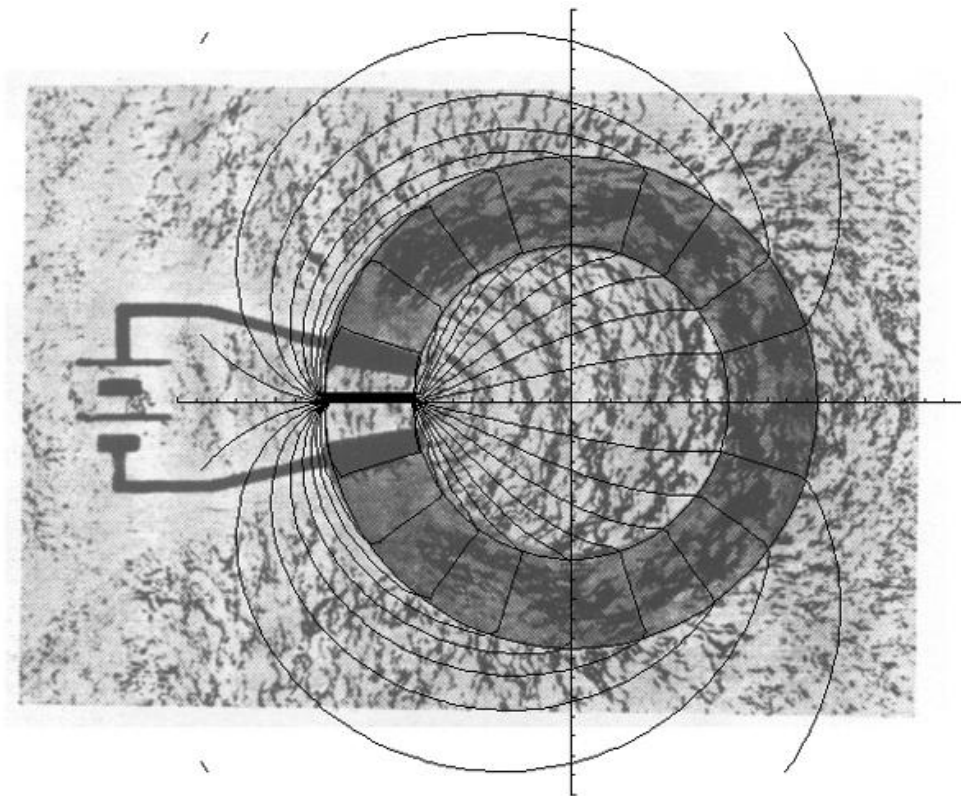
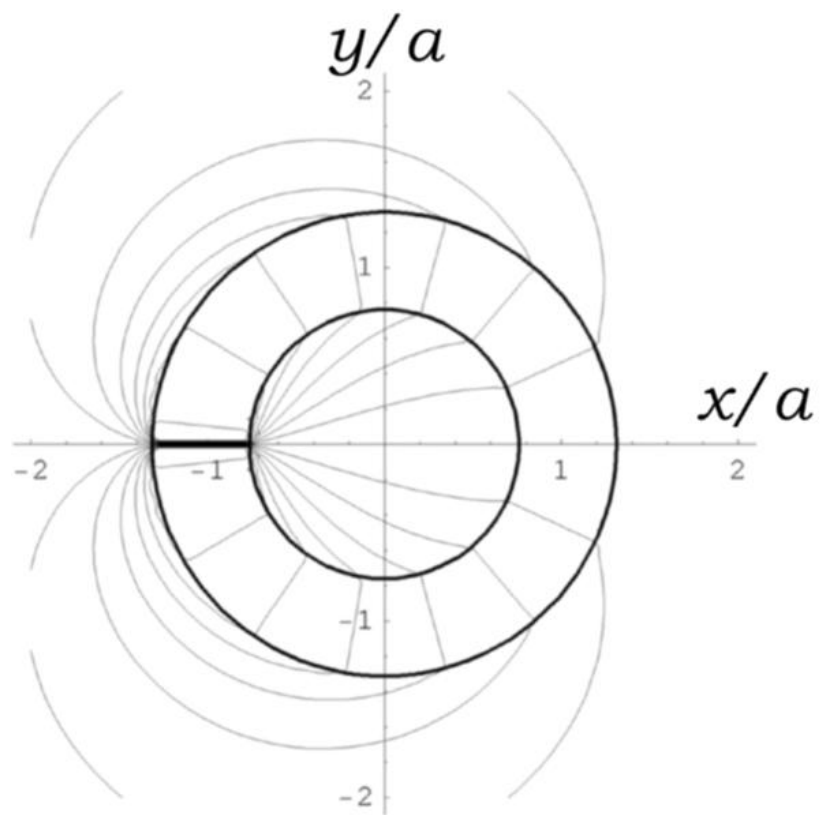

Density of surface charges in the resistive ring with steady current:

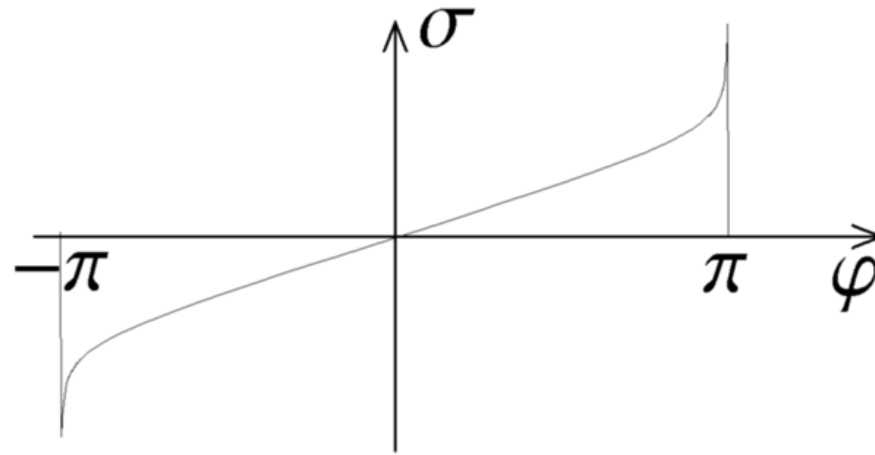

Weber in 1852: “The electric charge of the circuit increases from the neutral point to the contact point not uniformly, but accelerates gradually.”

Sansbury, Rev. Scientific Instruments 56, 415 (1985)

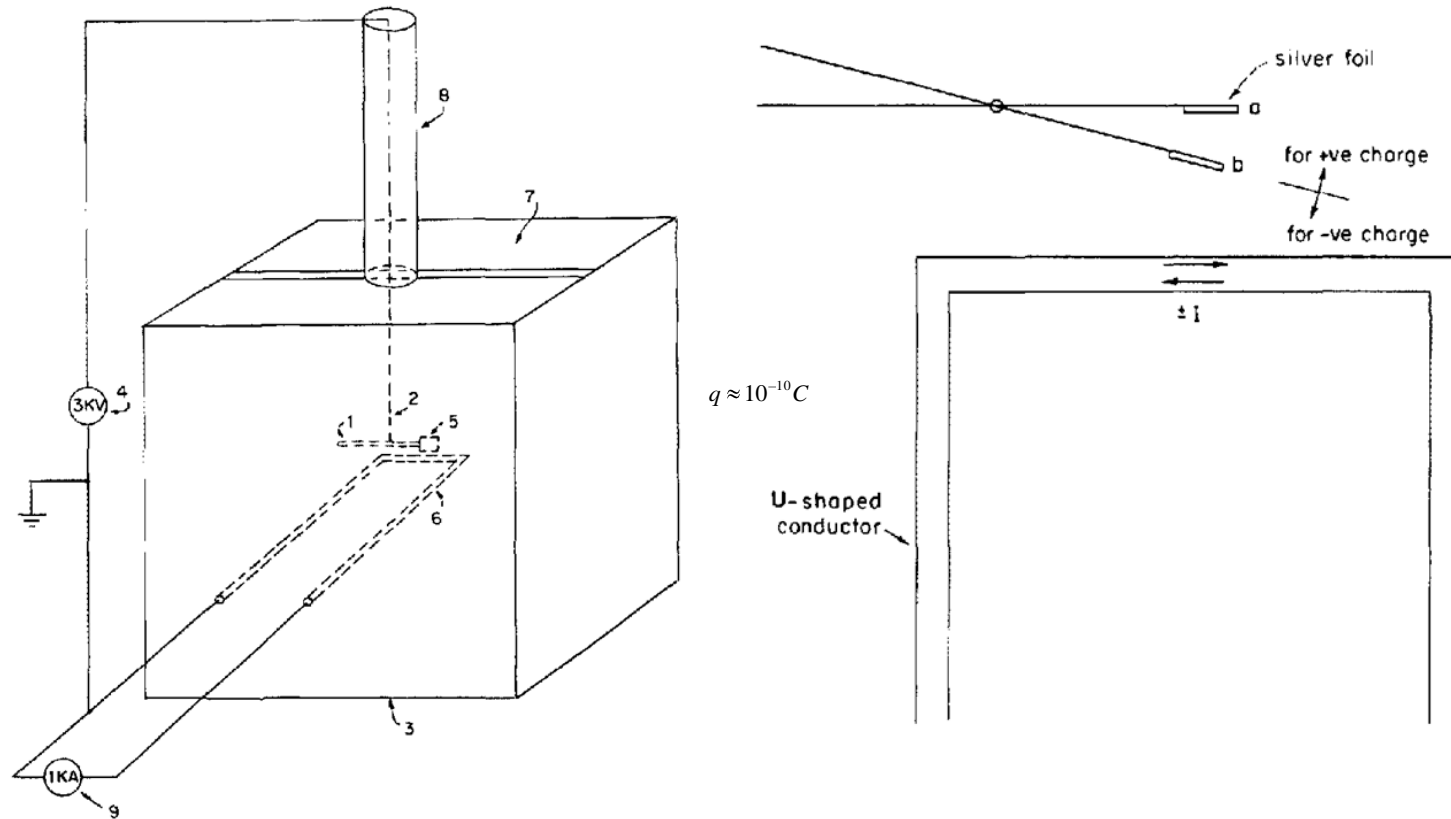

$$q \approx 10^{-10} C, \quad I \approx kA, \quad F \approx 10^{-7} N$$

Moreau et al., AJP 53, 552 (1985).

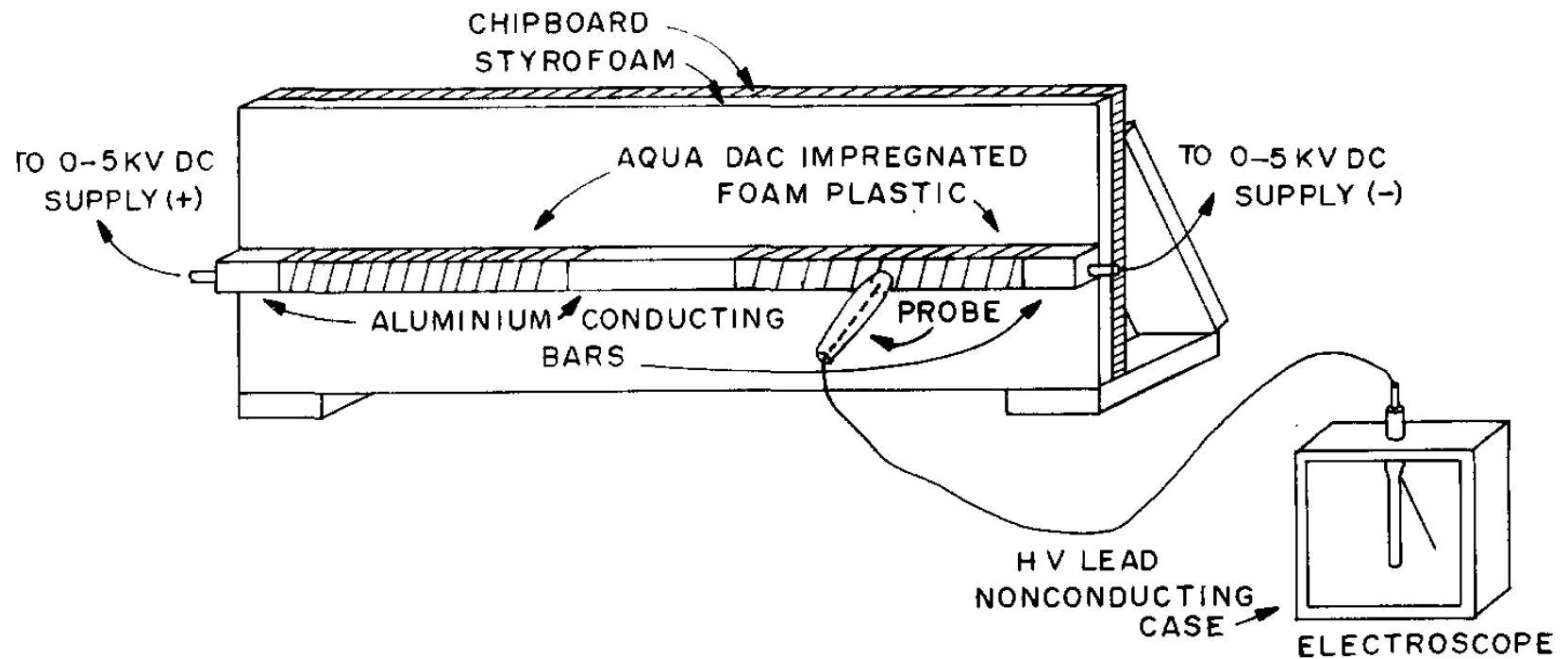

$$\Delta V = 2kV, \quad R_1 = R_2 = 75M\Omega, \quad I = 13\mu A$$

Chabay and Sherwood, Electric and Magnetic Interactions (2002).

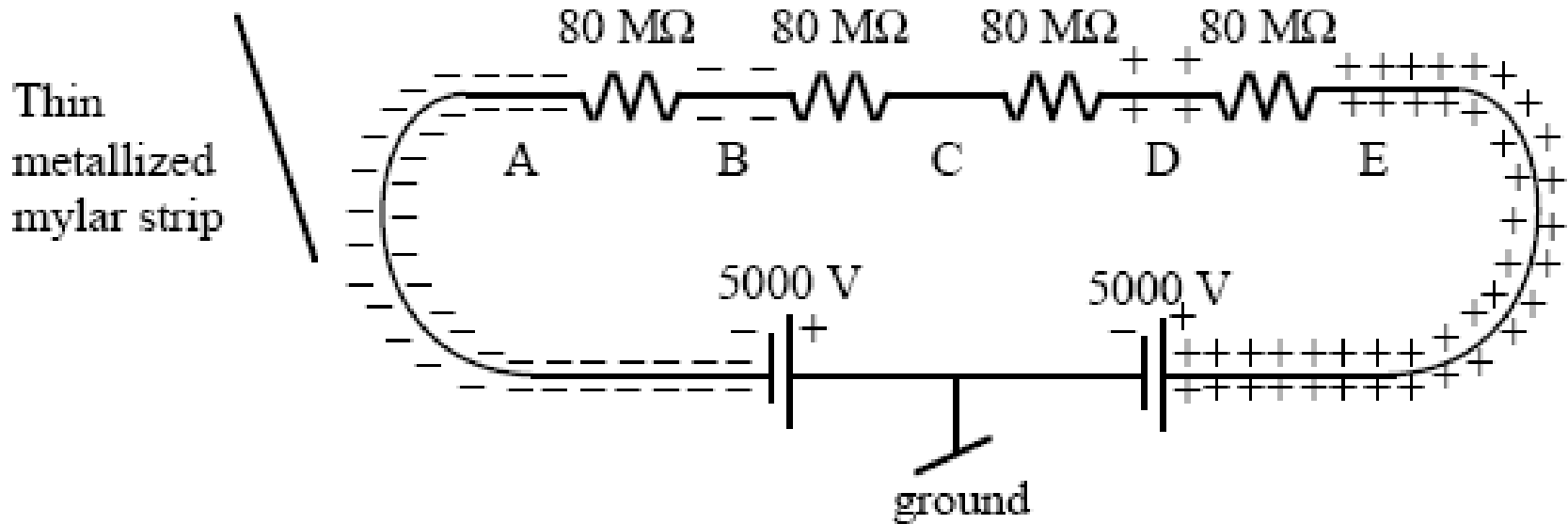

Video showing this experiment:

www.matterandinteractions.org/Content/Materials/Videos/SurfaceCharge.mov

The Electric Force of a Current

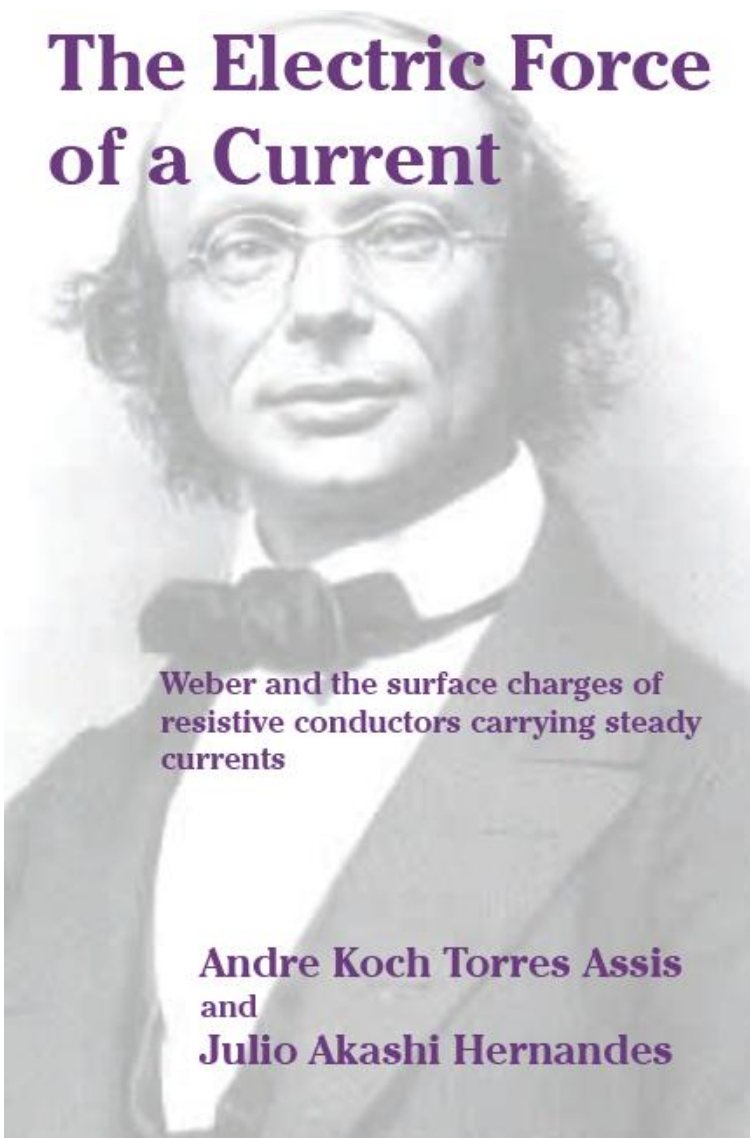
A grayscale portrait of Heinrich Weber, a German physicist and mathematician, wearing a dark suit, white shirt, and dark bow tie. He has long, wavy hair and is wearing glasses.

Weber and the surface charges of
resistive conductors carrying steady
currents

Andre Koch Torres Assis
and
Julio Akashi Hernandez

Assis and Hernandez,

The Electric Force of a Current

(Apeiron, Montreal, 2007)

www.ifi.unicamp.br/~assis

Conclusion:

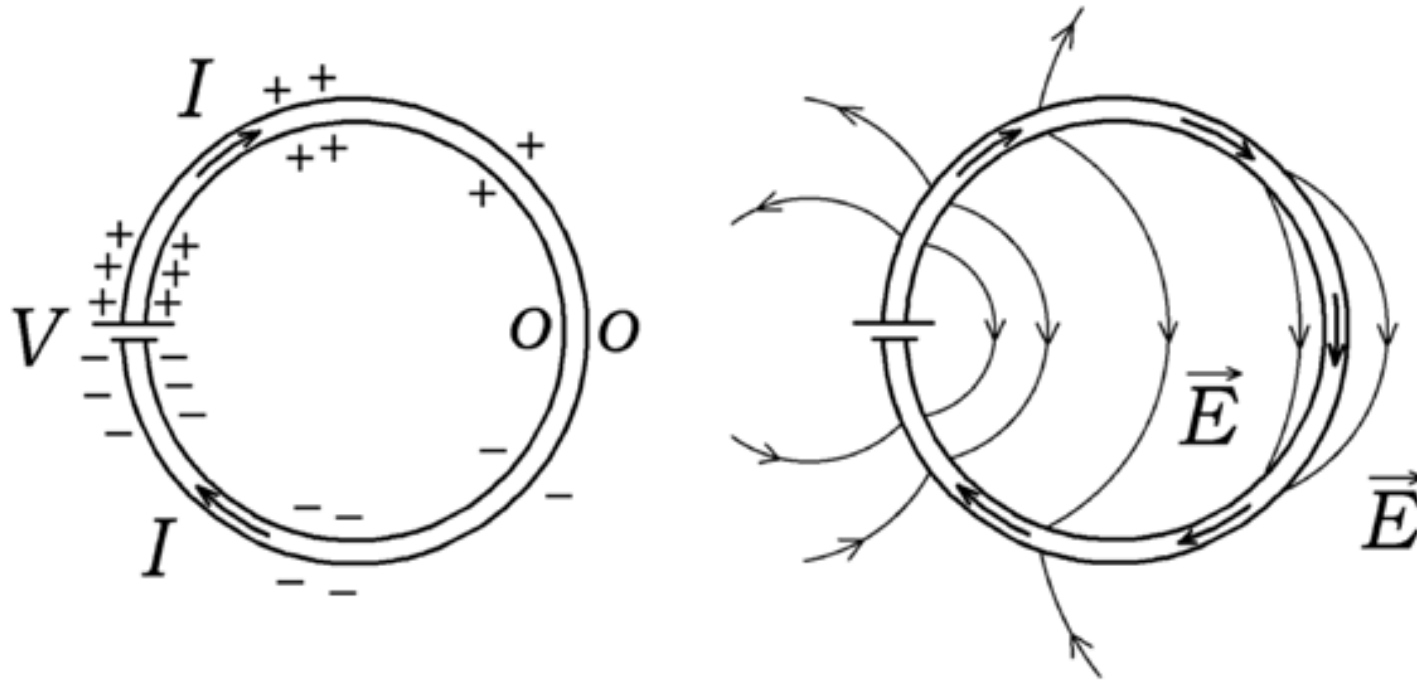

But Weber got there first!

www.ifi.unicamp.br/~assis

Additional material

Weber, 1852:

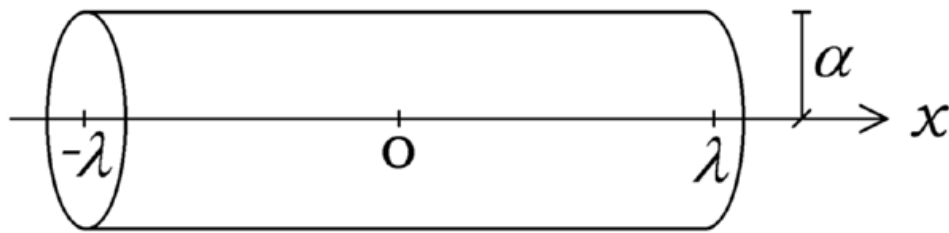

$$\sigma = A + Bx$$

$$\vec{E}(x) = \left(E_0 \ln \frac{\lambda}{\alpha} \right) \hat{i}$$

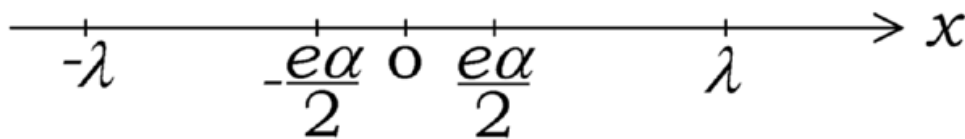

$$\sigma_L = A + Bx$$

Resistive strip

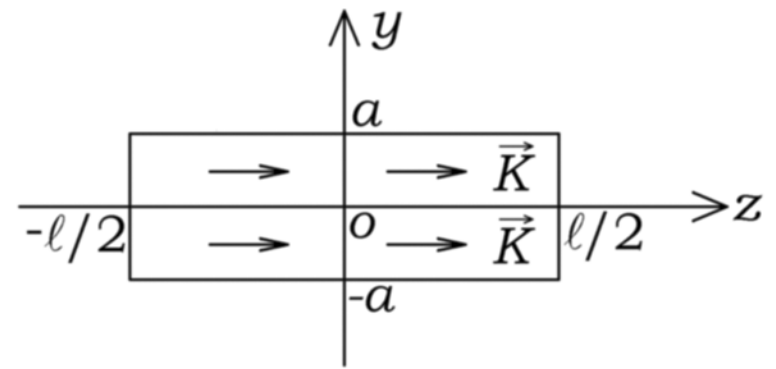

Elliptic-cylindrical coordinates

$$\sigma = \frac{k_1 + k_2 z}{\sqrt{a^2 - y^2}}$$

Jefimenko, AJP
30, 19 (1962).

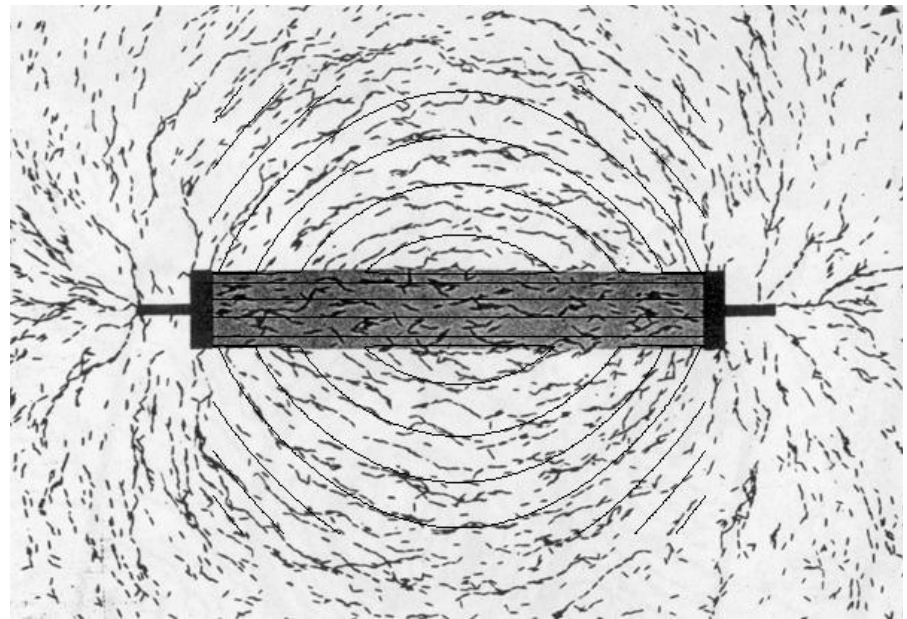

$$\Delta V = 10 \text{ kV.}$$

Lumped resistor, Heald, AJP 52, 522 (1984):

