



# Double Chooz: soon ready to build the detector

Angras, 24th of February

H. De Kerret



# A strong collaboration..

- **USA** Argonne National Lab.+ 6 universities (Univ. of Alabama, Univ. of Drexel, Kansas State Univ., Louisiana State Univ., Univ. of Notre Dame Univ. of Tennessee) US proposal - fall 04
- **Germany** : Max Planck Institute of Heidelberg + 3 universities (Hamburg, Munich, Tübingen)
- **Russia**: Kurchatov Institute + Science Academy
- **France**: CEA/Saclay + APC/Collège de France+ Subatech-Nantes
- **Italy** (still discussing)

... organized



- **Executive committee**
  - 2 persons/country
  - Phone meeting each 2 weeks
- **Working groups**
  - 12 working groups
- **Project manager** (F.Ardellier CEA) + **spokesperson** (HDK)

Executive management group



Director  
Spokesman & cc  
spokesamr

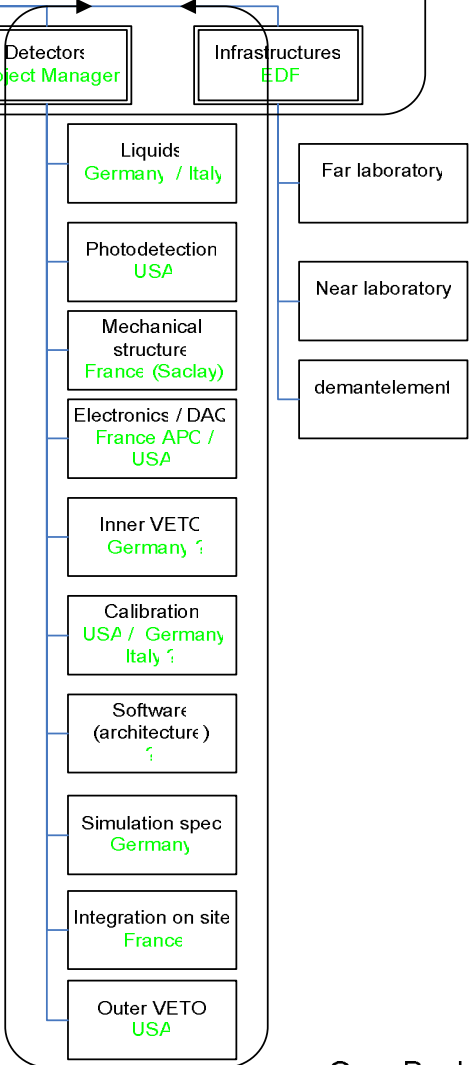
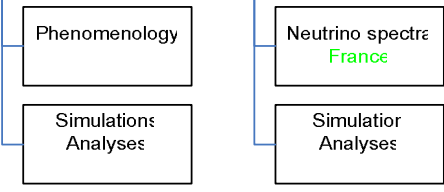
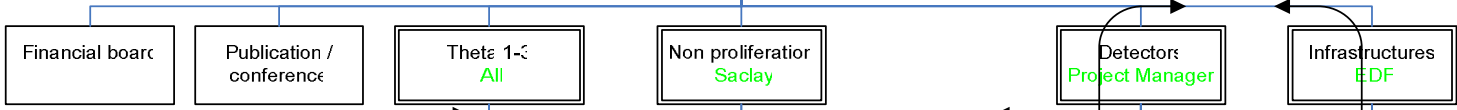

System group: technical board

Orga Double Chooz dec C



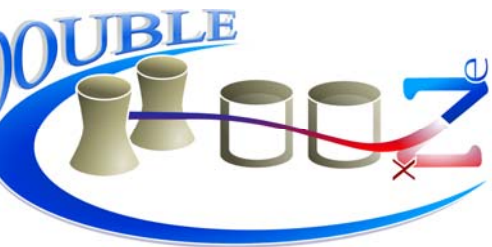

# US Management

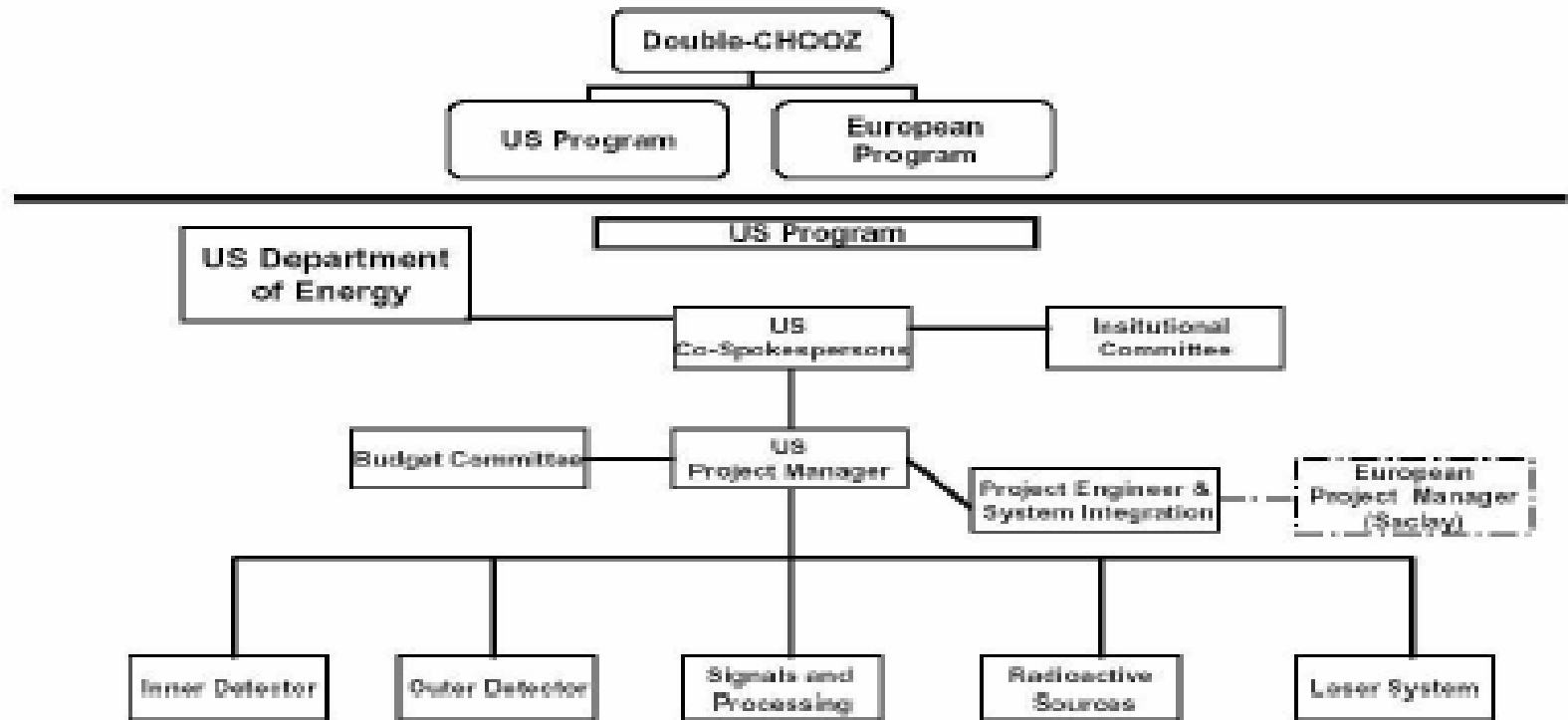
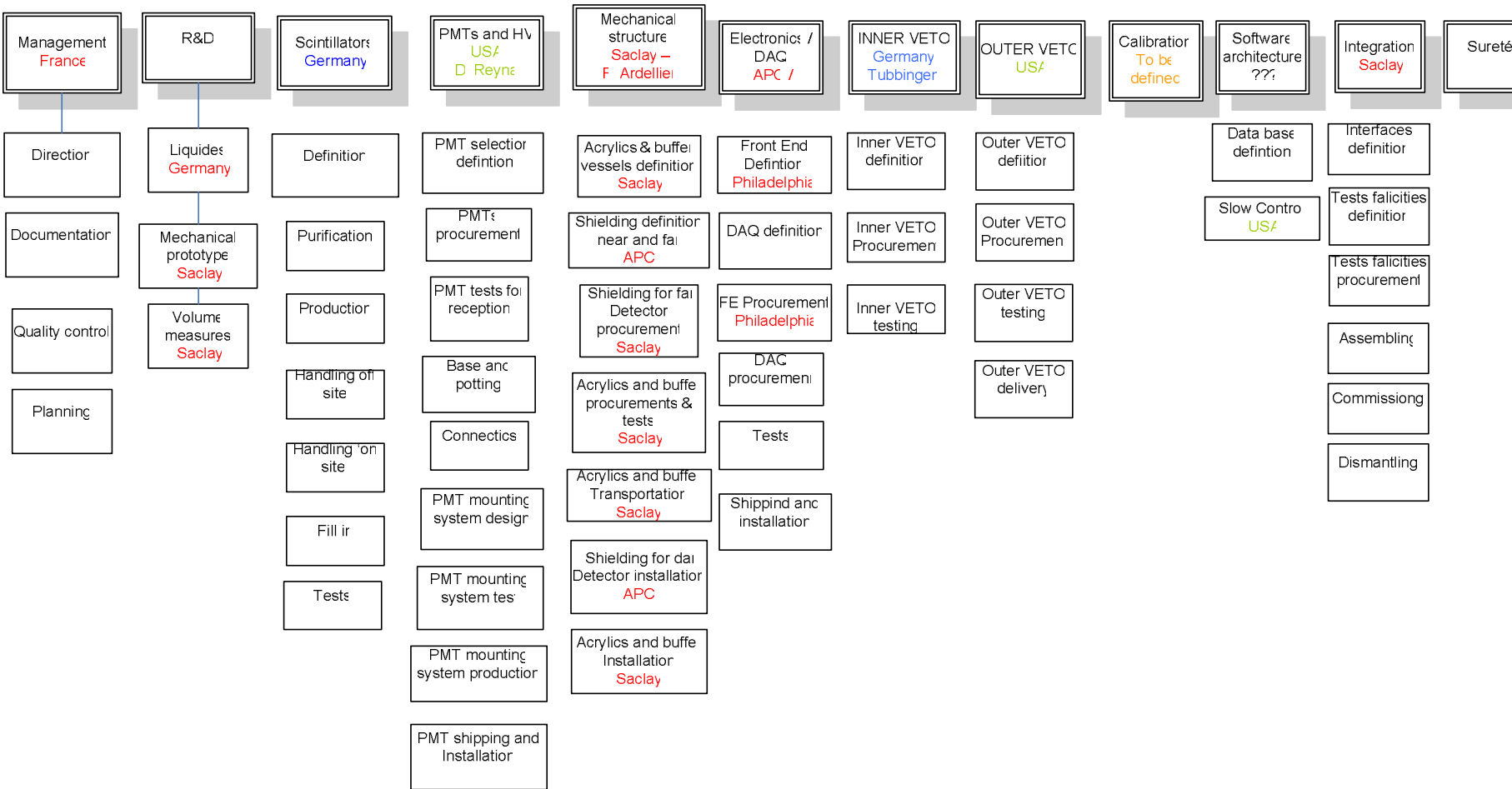

Figure 23: Proposed management structure for CHOOZ-US.

# Working Breakdown Structure



# WBS – Next Level: example of the outer veto

## Outer Veto WBS Structure

### 2.2 OuterVeto

#### 2.2.1 EDIA

- 2.2.1.1 Modules
- 2.2.1.2 Support Structure
- 2.2.1.3 Fabrication Tooling and Fixtures
- 2.2.1.4 Gas System

#### 2.2.2 Factory Setup

- 2.2.2.1 Module Assembly Fixtures and Tooling
- 2.2.2.2 Lifting and handling fixtures
- 2.2.2.3 Crimping and Stringing Fixtures

#### 2.2.3 Module Construction

- 2.2.3.1 Module component procurement
  - 2.2.3.1.1 Aluminum Tubes
  - 2.2.3.1.2 End-Plugs
  - 2.2.3.1.3 Brass Terminals
  - 2.2.3.1.4 Crimps
  - 2.2.3.1.5 Tungsten/Gold Wire
  - 2.2.3.1.6 Copper Tubing
  - 2.2.3.1.7 O-Rings
  - 2.2.3.1.8 Epoxy and RTV
- 2.2.3.2 Tube Assembly (Wire Stringing, End Plugs inserted, crimping, etc)
  - 2.2.3.2.1 Clean Tubes
  - 2.2.3.2.2 Insert Wire
  - 2.2.3.2.3 Insert and align endplugs
  - 2.2.3.2.4 Crimp Endplugs to Tubes
  - 2.2.3.2.5 Tension and crimp wire

#### 2.2.3.3 Module Assembly

- 2.2.3.3.1 Assemble tube on alignment fixture
- 2.2.3.3.2 Glue Tubes together
- 2.2.3.3.3 Insert Copper tubing
- 2.2.3.3.4 Attach straps and lifting points

#### 2.2.4 Module and Material Shipping

#### 2.2.5 Gas System

- 2.2.5.1 Component Procurement
  - 2.2.5.1.1 Tubing
  - 2.2.5.1.2 Fittings
  - 2.2.5.1.3 Manifolds
- 2.2.5.2 System Assembly

#### 2.2.6 Support Structure

- 2.2.6.1 Component Procurement
- 2.2.6.2 Travel
- 2.2.6.3 Assembly of Structure

#### 2.2.7 Installation of Modules

- 2.2.7.1 Misc. Materials
- 2.2.7.2 Travel
- 2.2.7.3 Installation



# Organisation of the technical group

Management group of detectors is called **'technical group'**

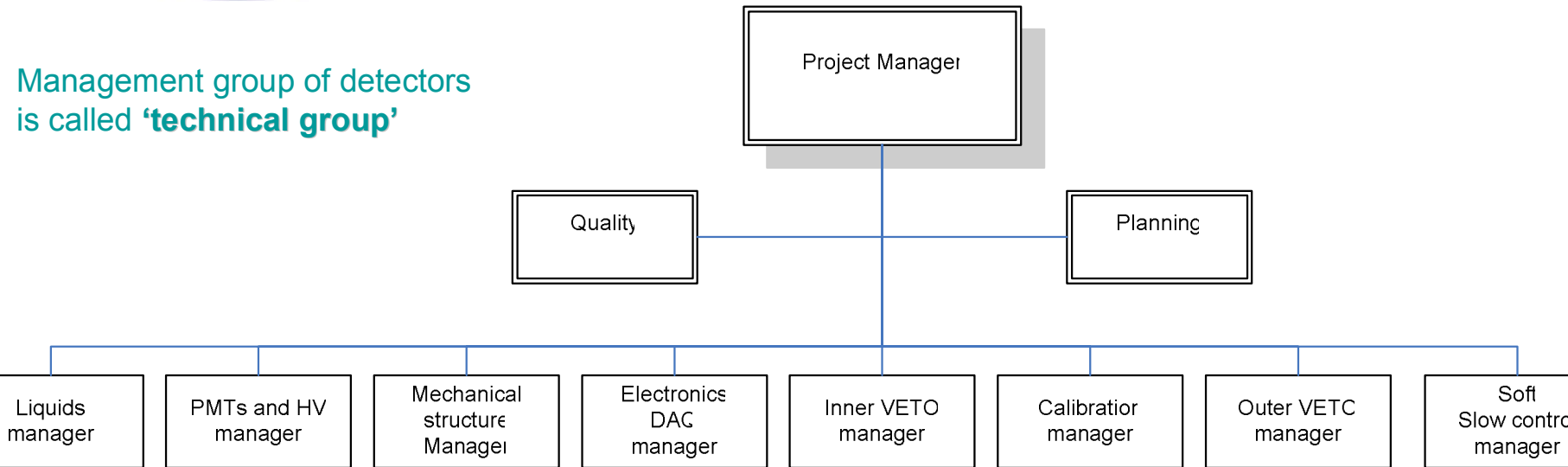

## Technical group :

### •Goals :

- Ensures compliance between specifications and production
- Monitor the schedule
- Coordinated the activities at detector level (development plan)
- Ensures compliance of sub systems interfaces (Interface Control Document)



# Interfaces identification at detector level Ongoing...

## Electrical interfaces :

- Outer VETO / DAQ
- Architecture system
- Slow control

## Chemical interfaces

- materials compatibility

## Interface detectors / labs

- radiopurity
- handling on site
- Safety, accessibility...

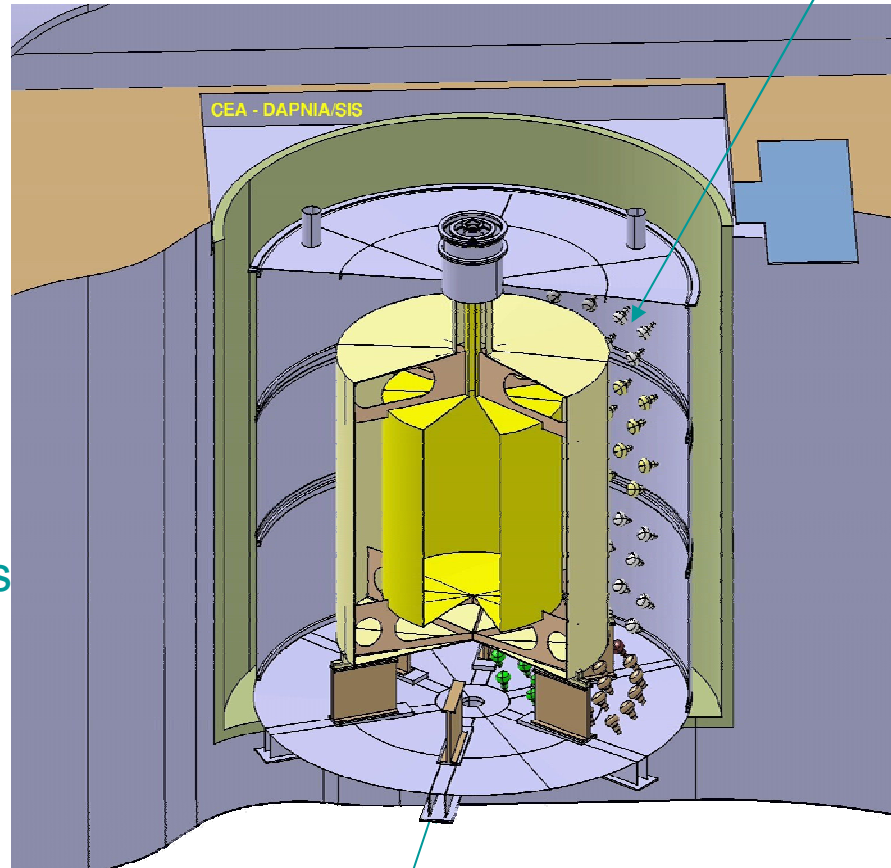

Mechanical interfaces Buffer / PMTs

Cables paths

Calibration

Mechanical Interfaces Buffer / inner veto vessel



# Development plan at detector level

- **June 2005** : technological prototype (1/5)
- **June / sept 2005** : Preliminary Design Review
  - General configuration of the detector is given
  - Interfaces between subsystems are defined
  - PMTs : elements are available for call for bid
- **Mid 2006** : Production Readiness Review
- **2007** : Commissioning / reception of the far detector
- **2008** : Commissioning / reception of the near detector





# Funding

- Total detectors cost: 9.5 Meuros
- Approved and funded in France (2.5Me)
- Discussion still ongoing with the electricity company EDF
  - They will not fund the civil engineering
  - Both French agencies accepted to take it in charge (unless the cost happen to be anomalously high: this is under study)
- In progress in other countries
  - Germany: to be reviewed in the next months by agencies
  - USA



## conclusion

- Start of the experiment building in June
  - Collaboration Meeting at Chooz
- Still room for serious new collaborators
  - Italy discussing
  - Work sharing does exist, but can be discussed





# US Budget

PMTs	\$2.11M
Outer Veto	1.32
Front End Electronics	0.23
High Voltage	0.42
Slow Controls	0.09
Calibration Deployment	0.24
Laser	0.05
Management	0.35
Total	\$4.86M