

21st CENTURY



SCIENCE & TECHNOLOGY

First English translation of Wilhelm Weber's *Determinations of Electrodynamic Measure* (1846), the report of groundbreaking work conducted with Carl Friedrich Gauss to prove the Ampère angular force. 146 pages in pdf. Posted March 2007.

<http://www.21stcenturysciencetech.com>

**DETERMINATIONS OF ELECTRODYNAMIC MEASURE:
Concerning a Universal Law of Electrical Action**

by Wilhelm Weber

[Treatise at the founding of the Royal Scientific Society of Saxony on the day of the 200th anniversary celebration of Leibniz's birthday, published by the Prince Jablonowski Society, Leipzig 1846, pp. 211-378.]

[Translated by Susan P. Johnson and edited by Laurence Hecht and A. K. T. Assis (homepage: <http://www.ifi.unicamp.br/~assis/>) from Wilhelm Weber, "Electrodynamische Maassbestimmungen: Ueber ein allgemeines Grundgesetz der elektrischen Wirkung," *Werke*, Vol. III: *Galvanismus und Electrodynamik*, part 1, edited by H. Weber (Berlin: Julius Springer Verlag, 1893), pp. 25-214. The author's notes are represented by [N. A.], the notes by H. Weber, the editor of this third volume of Weber's *Werke*, are represented by [N. H. W.], while the notes of the editors of this English translation are represented by [N. E.].]

The electrical fluids, when they are *moved* in ponderable bodies, cause reciprocal actions on the part of the *molecules of these ponderable bodies*, from which all galvanic and electrodynamic phenomena arise. These reciprocal actions of the *ponderable bodies*, which are dependent upon the *motions* of the electrical fluids, are to be divided into two classes, whose differentiation is essential to the more precise investigation of the laws, namely, (1) such reciprocal actions which those molecules exert upon one other, when the distance between them is immeasurably small, and which one can designate galvanic or electrodynamic *molecular forces*, because they occur in the interior of the bodies through which the galvanic current flows; and (2) such reciprocal actions which those molecules exert upon one another, if the distance between them is measurable, and which one can designate galvanic or electrodynamic forces acting *at a distance* (in inverse proportion to the square of the distance). These latter forces also operate between the molecules which belong to two different bodies, for instance, two conducting wires. One may easily see, that for a complete investigation of the laws of the *first* class of reciprocal actions, a more precise knowledge is required of molecular relationships inside the ponderable bodies than we currently possess, and that without it, one could not hope to bring the investigation of this class of reciprocal actions to a full conclusion by establishing complete and general laws. The case is different, on the other hand, with the *second* class of galvanic or electrodynamic reciprocal actions, whose laws can be sought in the forces which two ponderable bodies, through which the electrical fluids are moving, exert upon each other in a *precisely measurable position and distance with respect to one another*, without it being necessary to presuppose that the *internal molecular relationships* of those ponderable bodies are known.

From these two classes of reciprocal actions, which were discovered by Galvani and Ampère, a *third* class must meanwhile be fully distinguished, namely, the *electromagnetic* reciprocal actions, discovered by Oersted, which take place between the molecules of two *ponderable* bodies at a measurable distance from each other, when in the one the electrical fluids are put into motion, while in the other the magnetic fluids are separated. This distinction between *electromagnetic* and *electrodynamic* phenomena is necessary for presenting the laws, so long as Ampère's conception of the essence of magnetism has not fully supplanted the older and more customary conception of the actual existence of magnetic fluids. Ampère himself gave expression to the essential distinction to be made between these two classes of reciprocal actions in the following way:

“As soon as Mr. Oersted had discovered the force which the conducting wire exerted on the magnet,” he said on page 285 of his Treatise,^{1, 2} “one could in fact suspect that a reciprocal action might exist between two conducting wires. But this was not a necessary consequence of that famous physicist's discovery: for a soft iron bar also acts upon a magnetic needle, without, however, any reciprocal action occurring between two soft iron bars. As long as one knew simply the fact of the deflection of the magnetic needle by the conducting wire, could one not assume, that the electrical current simply imparted to this conducting wire the property of being influenced by the magnetic needle, in a way similar to that in which the soft iron was influenced by the same needle, for which it sufficed that it [the wire] acted on the needle, without any sort of effect resulting thereby between two conducting wires, if they were withdrawn from the influence of magnetic bodies? Simple experimentation could answer the question: I carried it out in September 1820, and the reciprocal action of the voltaic conductors was proven.”

Ampère rigorously develops this distinction in his Treatise, declaring that it is necessary for the laws of reciprocal action discovered by himself and Oersted to be separately and completely derived, each by itself, from experimental evidence. After he has spoken of the difficulties of precisely observing the reciprocal action of the conducting wires, he says on page 183, *loc. cit.*: “It is true that one meets with no such difficulties, when one measures the effect of a conducting wire on a magnet; however, this method cannot be used when it is a matter of determining the forces which two voltaic conductors exert upon each other. In fact, it becomes clear, that if the action of a conducting wire on a magnet, proceeds from a cause other than that which occurs between two conducting wires, the experiments made on the former would prove nothing at all with respect to the latter.”

From this, it becomes clear, that even if many fine experiments have been conducted more recently in further pursuit of Oersted's discovery, nothing has directly occurred yet toward further pursuit of Ampère's discovery, and that this requires specific and unusual experiments which hitherto have been sorely lacking.

Ampère's classic work itself is concerned only in a lesser way with the phenomena and laws of the reciprocal action of the conducting wires vis-à-vis each other, while the larger part is devoted to the development and application of his conception of magnetism, based on those laws. Nor did he consider his work on the reciprocal action between two conducting wires as in any way complete and final, either from an experimental or theoretical standpoint, but on the contrary, repeatedly drew attention to what remained to be done in both connections.

He states on page 181 of the cited Treatise, that in order to derive the laws of reciprocal action between two conducting wires *from experimental evidence*, one can proceed in two different ways, of which he could pursue only one, and presents the reasons which kept him from attempting the other way, the most essential being the lack of precise *measuring instruments*, free of indeterminable foreign influences.

“There is, moreover,” he says on page 182 f., *loc. cit.*, “a far more decisive reason, namely, the limitless difficulties of the experiments, if, for example, one intended to *measure* these forces by means of the number of vibrations of a body subjected to their influence. These difficulties arise from the fact that, when one causes a fixed conductor to act on a moveable part of a voltaic circuit those parts of the apparatus, which are necessary to connect it to the dry battery, have an effect on this moveable part as well as the fixed conductor, and thus destroy the results of the experiments.”

¹ [N. A.] Mémoire sur la théorie mathématique des phénomènes électrodynamiques uniquement déduite de l'expérience. Mémoires de l'académie royale des sciences de l'institut de France, 1823.

² [N. E.] There is a partial English translation in R. A. R. Tricker, *Early Electrodynamics – The First Law of Circulation* (New York: Pergamon, 1965), pp. 155-200: A. M. Ampère, “On the Mathematical Theory of Electrodynamics Phenomena, Experimentally Deduced.”

Likewise, Ampère repeatedly drew attention to what remains to be done from the *theoretical* standpoint. For example, he says on page 299, after showing that it is impossible to account for the reciprocal action of the conducting wires on each other, by means of a certain distribution of static electricity in the conducting wires:

“If one assumes, on the contrary, that the electrical particles in the conducting wires, set in motion by the influence of the battery, continually change their position, at every moment combining in a neutral fluid, separating again, and immediately recombining with other particles of the fluid of the opposite kind, then there exists *no contradiction* in assuming that from the influences which each particle exerts in inverse proportion to the square of the distance, a force could result, which did not depend solely upon their distances, but also on the alignments of the two elements, along which the electrical particles move, combine with molecules of the opposite kind, and instantly separate, in order to combine again with others. The force which then develops, and for which the experiments and calculations discussed in this Treatise have given me the quantitative data, depends, however, directly and indeed exclusively, on this distance and these alignments.”

“If it were *possible*,” Ampère continued on page 301, “to prove on the basis of this consideration, that the reciprocal action of two elements were in fact proportional according to the formula with which I have described it, then this account of the fundamental fact of the entire theory of electrodynamic phenomena would obviously have to be preferred to every other theory; it would, however, require investigations with which I have had no time to occupy myself, any more than with the still more difficult investigations which one would have to undertake in order to ascertain whether the opposing explanation, whereby one attributes electrodynamic phenomena to motions imparted by the electrical currents of the ether, could lead to the same formula.”

Ampère did not continue these investigations, nor has anyone else published anything to date, from either the experimental or theoretical side, concerning further investigations, and since Ampère, science has come to a halt in this area, with the exception of Faraday's discovery of the phenomena of galvanic currents induced in a conducting wire when a nearby galvanic current is increased, weakened, or displaced. This neglect of electrodynamics since Ampère, is not to be considered a consequence of attributing less importance to the fundamental phenomenon discovered by Ampère, than to those discovered by Galvani and Oersted, but rather it results from dread of the great difficulty of the experiments, which are very hard to carry out with present equipment, and no experiments were susceptible of such manifold and exact determinations as the electromagnetic ones. To remove these difficulties for the future, is the purpose of the work to be presented here, in which I will chiefly confine myself to the consideration of purely galvanic and electrodynamic reciprocal actions *at a distance*.

Ampère characterized his mathematical theory of electrodynamic phenomena in the title of his Treatise as *derived solely from experimental results*, and one finds in the Treatise itself the simple, ingenious method developed in detail, which he used for this purpose. In it, one finds the experiments he selected and their significance for the theory discussed in detail, and the instruments for carrying them out fully and precisely described; but an exact description of the experiments themselves is missing. With such fundamental experiments, it does not suffice to state their purpose and describe the instruments with which they are conducted, and add a general assurance that they were accompanied by the expected results, but it is also necessary to go into the details of the experiments more precisely, and to state how often each experiment was repeated, what changes were made, and what influence those changes had, in short, to communicate in protocol form, all data which contribute to establishing a judgment about the degree of reliability or certainty of the result. Ampère did not make these kinds of more specific statements about the experiments, and they are still missing from the completion of an actual direct proof of the fundamental electrodynamic law. The fact of the reciprocal action of conducting wires has indeed

been generally placed beyond doubt through frequently repeated experiments, but only with such equipment and under such conditions, that *quantitative* determinations are out of the question, not to speak of the possibility that these determinations could achieve the rigor required to consider the law of those phenomena as empirically proven.

Now, Ampère, of course, more frequently made use of the *absence* of electrodynamic effects which he observed, similar to the use of measurements which yield the result = 0, and, by means of this expedient, he attempted, with great acuity and skill, to obtain the most necessary basic data and means of testing for his theoretical conjectures, which, in the absence of better data, was the only method possible; we cannot, however, in any way ascribe to such *negative* experimental results, even if they must temporarily take the place of the results of *positive* measurements, the entire value and the full force of proof which the latter possess, if the negative results are not obtained with the use of such techniques, and under such conditions, where true measurements can also be carried out, which was not possible with the instruments used by Ampère.

One may consider more precisely, for example, the experiment which Ampère describes on page 194 ff. of his Treatise as the third case of equilibrium, where a metal arc lies on two trays filled with mercury, from one of which the current is introduced and from the other drawn off, and where, additionally, the arc is fastened by a hinge to an arm which connects it with a vertical shaft pivoting between the ends.³ Ampère now observed that, while a galvanic current is passing through

³ [N. A.] Ampère gives in another location the following description of his instrument: On a frame TT' (Figure 1) in the form of a table two vertical poles EF and EF' protrude, bound together by crosspieces $LL' FF'$; an axle GH is held in a vertical position between these two crosspieces. Its two ends G and H are sharpened and are seated in conical depressions, one of which is in the lower crosspiece LL' , the other on the end of a screw KZ which passes through the upper crosspiece FF' and which serves to steady the axle GH without fixing it. An arm QO is fastened at C to the axle. The end of the arm is equipped with a hinge, into which fits the middle of an arc AA' , which is formed from a conductor. The arm, whose radius is equal to the distance from O to the axle GH , is always in a horizontal position. This arc is balanced with a counterpoise at Q , in order to decrease the friction at points GH where it is seated in the conical depressions.

Under the arc AA' are two trays M and M' filled with mercury, so that the surface of the mercury, which rises above the rim of the tray, just touches the arc AA' at B and B' . These two trays communicate through the metallic conductors MN and $M'N'$ with the mercury-filled cups P and P' . The cup and the wire MN which connects it with the tray M are fastened on a vertical axle, which sits on the table so that it can turn freely. This axle passes through the cup P' , with which the wire $M'N'$ is connected, in order that it may turn independently from the other cup. The axle is insulated by a little glass tube which surrounds it, and is kept separate by a little glass disc from the conductor of the tray M , so one may form an arbitrary angle with the conductors MN and $M'N'$.

Two other conductors, JR and $J'R'$, fastened to the table, are submerged respectively in cups P and P' , and connect these with mercury-filled depressions in the table R and R' . Finally, between these two depressions, there is a third, S , also filled with mercury.

that arc, it is not displaced from its supports, if a closed circuit of current is made to act upon the arc, provided that the midpoint of the arc falls on the axis of the shaft to which the arc is attached. However, one easily sees that, in order to put the arc into motion, a fourfold friction must be overcome, namely, the friction on the two supports on which the arc is lying (arc AA' on B and B' in Figure 1), and the friction on the two ends G and H , on which the vertical shaft pivots. Further, it is known that the electrodynamic forces which are produced with the strongest imaginable galvanic current in a simple wire, like the section of the arc BB' with current flowing through it, are so weak, that the wire must be extremely mobile, in order to show any perceptible effect at all. One would accordingly be inclined to expect, that that arc would not be displaced in the case where its midpoint lay in the axis of rotation, but also that in the opposite case, where its midpoint did not coincide with the axis of rotation, no displacement would occur, because the just-cited fourfold friction would counterpose far too great a resistance. Ampère now says, nevertheless, on page 196, *loc. cit.*: “When, by means of the hinge O , the arc is placed in such a position that its center lies outside the GH axis, the arc takes on motion and slides on the mercury of the little troughs M and M' , in virtue of the action of the closed curvilinear current which goes from R' to S . If, on the contrary, its midpoint is on the axis, it remains immobile.” It is regrettable, that Ampère did not mention the obvious problem of that fourfold friction, and never explicitly says that he himself saw and observed the movement of the eccentric arc. However, aside from the doubt that could therefore be raised about the actual observation of the datum, and assuming that Ampère himself

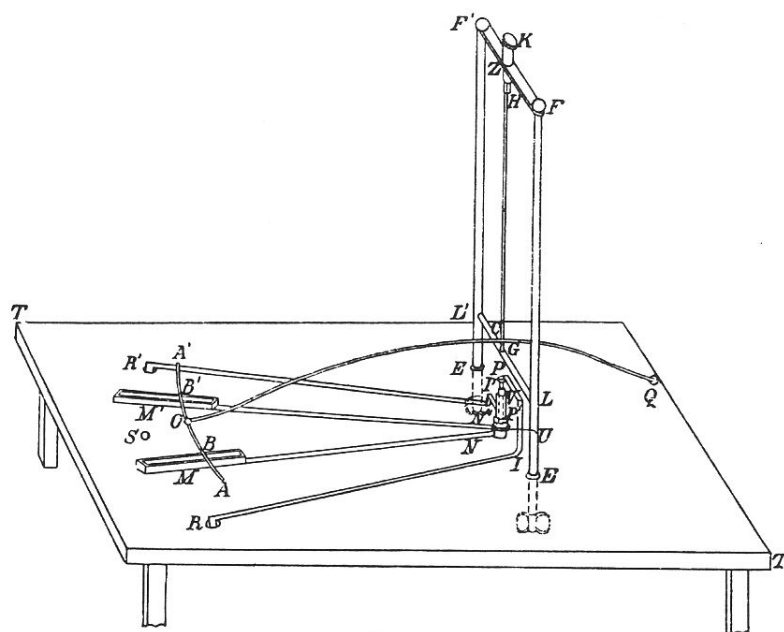

Fig. 1.

The apparatus is used in the following way: One battery lead, for instance, the positive, is dipped into depression R , and the negative into depression S , and the latter is connected with depression R' through an appropriately bent conductor. The current goes through the conductor RJ to cup P , from there through the conductor NM to tray M , through the conductor $J'R'$, and finally from the depression R' through the arbitrarily curved conductor to depression S , in which the negative battery lead is dipped.

The voltaic circulation is accordingly formed: (1) from arc BB' in contact with conductors MN and MN' ; (2) from a circuit, which from the part RJP and $P'J'R'$ of the device, out of the curved conductor which goes from R' and S and from the pillar itself originates. The latter circuit works like a closed one because it is only interrupted by the thickness of the glass plate which separates the cups P and P' ; hence, it suffices to observe its action on the arc BB' in order to experimentally confirm the effect of a closed current on an arc at the different positions which one can set up with respect to it.

saw the displacement of the arc under the conditions described, and also made certain that it had actually been the effect of *electrodynamic* forces, which were strong enough, to overcome all opposing obstacles, it is still in no way stated at what eccentricity of the arc this motion began, and within which *limits* it did *not* occur. Yet without determining such limits, no full force of proof can be attributed to this experiment. It is not known to me whether, since that time, this experiment has been successfully repeated and more precisely described by other physicists, yet this much can be summarily stated, that even in the most favorable of cases, the displacement occurred only at great eccentricities, from which, however, it cannot be concluded that the electrodynamic force acts precisely at right angles to the elements of the arc.

By means of these remarks about Ampère's experiments, I have only wished to demonstrate that the electrodynamic laws have found no sufficient proof in these experiments, communicated as they are without more precise details, and why I believe that such a proof could not be given by means of observations with Ampère's instruments, but instead, observations are required with precise measuring instruments which have not previously been used. If, despite the lack of direct factual proof, one remains convinced of the correctness of the laws advanced by Ampère, this conviction is based on grounds which in no way make direct proof superfluous. Electrodynamic measurements hence remain desirable in order to provide the direct proof which is lacking.

In fact, amidst the universal attempt to determine all natural phenomena according to number and measure, and thereby to obtain a basis for theory which is independent of either sensory perception or mere estimation, it seems amazing that in electrodynamics, no attempt of this kind has been made; nevertheless, I am aware of neither refined nor gross measurements of the reciprocal actions of two conducting wires vis-à-vis each other. All the more do I consider myself authorized to present here the first attempts which I have made toward such measurements. I hope thereby to prove, that these electrodynamic measurements possess importance and significance in quite other respects than as proof of the fundamental electrodynamic laws, namely, by becoming the source of entirely new investigations for which they are uniquely suited, and which, indeed, cannot be conducted without them.

1.

Description of an instrument for the measurement of the reciprocal action of two conducting wires.

The instruments Ampère used for his electrodynamic experiments, are not of the sort that allow the probative force of more rigorous measurements to be ascribed to the experiments made with them. The reason for this lies in the *friction* which often annuls the entirety of the electrical force to be observed, or a large part of it, and eliminates it from observation. Neither is it possible with those instruments, even under favorable conditions, to overcome this adverse friction by means of the weak electrodynamic forces, while by any more rigorous measurement it must be presupposed that the friction is a negligible fraction in comparison with the force to be measured.

Already, twelve years ago, for the purpose of excluding friction and introducing truer measurements, I equipped a wire wound on a thin wooden frame, through which a galvanic current was to be conducted, and which then was to be set into motion by the electrodynamic attraction and repulsion of a multiplier, with a *bifilar* suspension of two fine metal wires (in future, I will call these wire spirals with bifilar suspension the *bifilar coils*) and used one of these suspension wires for supplying the galvanic current, the other for drawing it off. I first came to know the full significance of this apparatus for the purpose of measurement, however, by way of the bifilar magnetometer of Gauss, from whom I then borrowed the use of a mirror fastened to the bifilar coil. In the summer of 1837, I made such an instrument and carried out a series of experiments with it, all of which prove, that one can achieve the greatest refinement in the observation of

electrodynamic phenomena with currents so weak, that previously, no one ever succeeded in eliciting these phenomena with them.

The instrument to be described here firstly, was constructed by Inspector Meyerstein in Göttingen in 1841, yet it was in Leipzig that I first found occasion to provide a suitable setup for a greater series of measurements.

This instrument consists essentially of two parts: the *bifilar coil* with a mirror, and the *multiplier*.

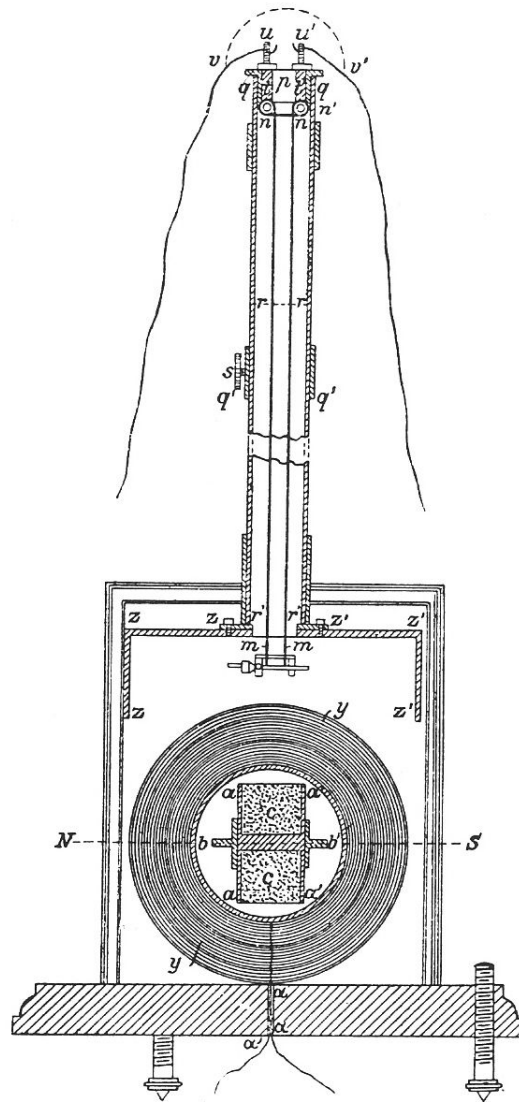

Fig. 2.

The *bifilar coil*, which is presented in a vertical cross-section in Figure 2, consists of two thin brass discs aa and $a'a'$ of 66.8 mm diameter, which are held in a fixed position by a 3-mm thick brass axis bb' at a distance of 30 mm apart. Around this axis between these discs is wound roughly 5,000 times a copper wire cc of 0.4 mm diameter, sheathed in silk, which completely fills up the space between the two discs. Figure 3 presents this coil in a vertical cross-section perpendicular to the previous one. One end of the wire is led, close to the brass axis, through a

small opening lined with ivory in one disc at e (Figure 3) outward from e to e' ; the other end is fastened at d on the periphery of the cylinder formed by the wire windings with silk thread.

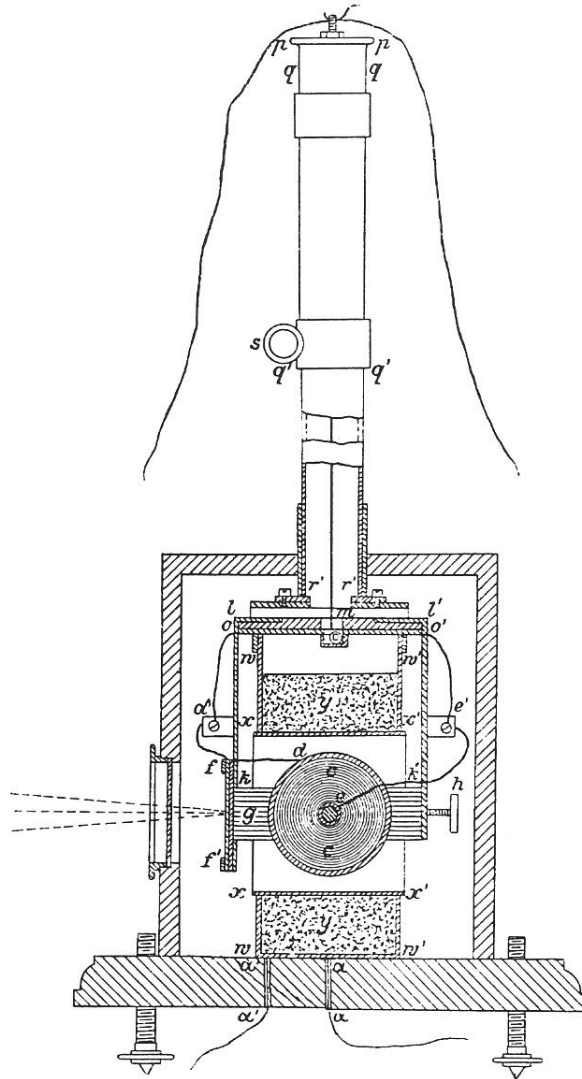

Fig. 3.

A plane mirror ff' (Figure 3) is now attached to this wire coil, and fixed by three screws to a small brass plate; the brass plate is equipped with two right-angled extensions g and g' , of which in Figure 3 only the rear one, g , is visible. Figure 4, which gives the horizontal cross-section, shows both extensions connected with the brass plate holding the mirror ff' . These two extensions are screwed at their ends to the outsides of the two brass discs aa and $a'a'$. The mirror ff' is located in a plane parallel to the axis bb' of the wire coil close to the periphery of the coil; diametrically opposite to it, a counter-weight h is mounted. I use now a square plane mirror ground in Berlin by Oertling; its sides are 40 millimeters long.

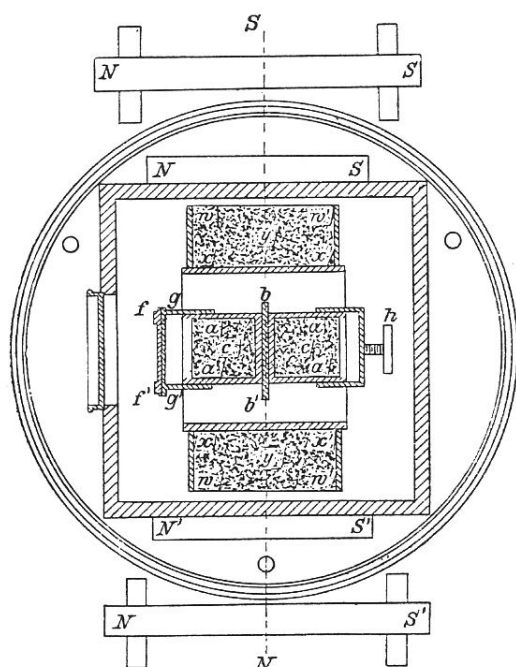

Fig. 4.

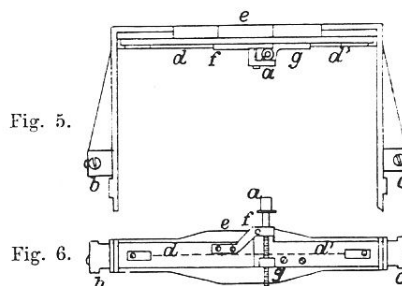

Fig. 5.

Fig. 6.

The *bifilar suspension* of this wire coil consists of three parts: the halter fastened onto the coil, the two suspension wires, and finally the immovable support from which the wires hang. The *halter* consists of a forked brass bracket or bow (Figure 3, *ll'*), with two 100-mm-long parallel vertical arms *lk* and *l'k'*, 100-mm apart. The ends of both arms are screwed fast at *k* and *k'* to the brass plate which holds up the mirror, and, diametrically opposite, to the holder of the counterweight. Figure 5 in particular shows this halter; at *d* and *d'*, the two wires coming from *b* and *c* pass under two ivory plates which can be adjusted by means of screw *a*, and pass through two grooves in the ivory plates, which are in contact with each other at the center, and vertically upward through the opening *e*. Figure 6 gives the view of the halter from below; at *f* and *g*, the connection of the screw *a* with the two ivory plates is represented. The vertical going through the center of gravity of the coil passes through the middle of the area between the two grooves. At each arm of the bow, finally, is located at *d'* and *e'* (Figure 3) a clamp insulated with ivory for fastening and connecting one of the silk-coated wires from each end of the coil with the lower end of one of the two uncoated suspension wires. The suspension wire is led from this clamp *d'* or *e'* through a small opening lined with ivory *o* or *o'*, along the underside of the bow, to one of the two already mentioned grooves on the ivory plates which meet each other at the center, whence the wire goes upwards to the little brass cylinder at *n* and *n'* (Figure 2). The two suspension wires are copper, 1 meter long, and 1/6 meter thick; their distance apart, to be regulated by screw *a* (Figure 6), is usually 3 to 4 millimeters.

The *support*, to which both upper ends of the two suspension wires are fastened, consists of a strong piece of ivory *p* (Figure 2), which is fitted tight like a lid on the upper end of a 30-mm-wide brass tube *qq'*. This brass tube is 150 mm long and allows a second brass tube, *rr'*, to pass through it, be rotated, and be adjusted by a set-screw *s* (Figure 3). These two tubes surround the two suspension wires along their entire length, and protect them from the influence of the air. On the underside of the piece of ivory, are attached two little movable brass rollers *t* and *t'* (Figure 2) of 10 mm diameter, fastened to the ivory with screw clamps *u* and *u'*; over each of these little rollers is led a suspension wire, which terminates in an eyelet. Both eyelets of the two wire ends are bound together with a strong silk thread between *t* and *t'*, without touching each other. By means of these two little rollers and the binding together of the two wires, the two suspension wires are made to

always have the same tension. To each of the two clamps u and u' , which fasten the two little rollers to the ivory, is, finally, fastened a coated copper wire, of which uv (Figure 2) serves to supply the galvanic current, $u'v'$ to draw it off.

The *multiplier*, finally, consists of two square copper plates ww and $w'w'$ (Figs. 3, 4), with sides of 140 mm, with a circular hole of 76 mm diameter. These two copper plates stand parallel and vertical, and are connected by a horizontal brass tube xx' of 76 mm diameter, by means of which they are kept at a 70-mm distance from one another. In the space yy above these tubes between those two parallel plates is wound approximately 3,500 times the 0.7-mm-thick multiplier wire. The upper side of the multiplier is closed off with a brass cover $zzz'z'$ (Figure 2), which is screwed tight onto it, and has a circular opening in the center of its upper side, above which the brass tubes surrounding the suspension wires stand. On both sides of this cover, slots are placed, through which the bow of the bifilar coil can pass and swing freely. The space between the uppermost windings of the multiplier wire and the cover is also wide enough, that each arm of the bow finds sufficient room for its movements. The bow is first stuck through without the bifilar coil and fastened to the suspension wires, and only then is it screwed to the bifilar coil. The protruding lower edges of the two brass plates on the multiplier stand on a wooden plate, which can be made level by means of three screws. In this wooden plate are two holes aa and $a'a'$ (Figure 3), through which the two ends of the multiplier wire are led toward the outside. The whole instrument, with the exception of the brass tubes in which the suspension wires are located, is contained in a mahogany casing, for protection against the influence of the air. This mahogany casing has no floor, but is placed with the level edges of the side walls flush with the wooden plate, by means of which it is closed off from below. On the upper side is placed a round opening, through which the already mentioned brass tube passes. A second opening is made on the front side of the casing and can be closed with a plane of glass. Through it the light of the scale falls on the mirror of the *bifilar coil* and is thrown back to the telescope. The entire casing is vertically divided in two halves, of which an individual half can be taken away. The arrangement of the telescope and the scale is exactly the same as in the magnetometer. In future I will designate the instrument described here with the name *electrodynamometer*, or *dynamometer* for short, because its most immediate destiny is to measure the electrodynamic forces discovered by Ampère.

2.

The electrodynamic force of two components of a circuit is proportional to the square of the current intensity.

The *intensity* of a constant current is determined by the *amount* of electricity, which during the time-unit (during a second) goes through a *cross-section* of the circuit. This determination of the intensity of the current is, however, not suitable as the basis of a practical method for *measurement of the intensity of the current*; for that, two measurements would be required, of which one cannot be performed at all, the other not with precision: namely, a definite amount of electricity cannot be precisely measured under the prevailing conditions, and the length of time in which it flows through the cross-section of the conducting wire can not be measured at all. For actual practical application, it is necessary to make use of another method of measuring the current-intensity. Such a method, wholly conforming to requirements, is offered by the *magnetic effects* of the currents, and will always be the standard method here. Accordingly, two currents, conducted successively through the same multiplier, that exert the same force on the same permanent magnet at the same distance and in the same position, have the same intensity; if the force they exert differs, then their intensities are related as these forces, and can be measured with the help of the usual *galvanometer*.

If different currents are now put through the same circuit successively, whose intensities, according to this measurement, are in the ratio 1 : 2 : 3 and so forth, then the electrodynamic reciprocal actions of two components of the circuit, through which these different currents are passing, are in the ratio of the series of the square of those intensities, i.e., 1 : 4 : 9 and so forth. The correctness of this law is now to be proven by means of the following electrodynamic measurements, which, even if the above law required no proof, would have their own interest, as the first example of the general rigor which it is possible to achieve in electrodynamic measurements.

The *dynamometer* described in the previous Section was placed on a stone ledge, without any iron or magnets in its immediate surroundings, in such a way that the plane of the fixed coil, or multiplier, was parallel to the magnetic meridian, and the plane of the bifilar coil was also vertical, but formed a right angle with the plane of the multiplier. The position of the multiplier could easily be adjusted, since it was possible to examine the vertical placement with sufficient exactness by means of a level, which was set on the cover of the multiplier, and the orientation was regulated by means of a compass also placed on the cover of the multiplier. The bifilar coil assumed a vertical position on its own when it was hung up, but whether the plane of the bifilar coil formed a right angle with the magnetic meridian, had to be tested by means of special experiments.

I.e., it is a proof of the correct position of the latter, if it remains unchanged even when an arbitrarily strong positive or negative current is put through the bifilar coil alone, because in the event of any appreciable deviation from that position, the terrestrial magnetism had to either increase or decrease this deviation. In this way, the magnitude of the deviation can also be determined. Such a test came about when the western radius of the bifilar coil was to be turned by 14 minutes toward the north, in order to place the plane of the bifilar coil exactly perpendicular to the magnetic meridian. The instrument offered no suitable way to carry out this small correction with precision, and apart from the fact that such a small deviation did not appreciably affect the results, doing away with it would have had no lasting utility, because continued observations showed, that hanging the bifilar coil at the upper end of a one-meter-high free-standing brass cylinder offered no security against rotations on the part of the bifilar coil which began gradually and increased for a few minutes. Suspension from an isolated fixed stone column was the only way to provide complete security from such small deviations.

The mirror fastened to the western radius of the bifilar coil stood vertically, and in the vertical plane, its horizontal normal was placed about 6 meters distant from a telescope equipped with crosshairs. A scale, as used in the magnetometer, was mounted on the fixed base of the telescope, just as in the magnetometer. Measurement showed the horizontal distance of the mirror from the scale:

$$= 6018.6 \text{ scale degrees,}$$

from which the arc measure of a scale degree resulted:

$$= 17.136''.$$

After this setup of the dynamometer for measuring the electrodynamic reciprocal action of the multiplier and the bifilar coil when a galvanic current is put through them, an *electromagnetic* apparatus for measuring the intensity of the current was now required for the investigation in hand.

3.

Description of an electromagnetic apparatus for measuring the intensity of galvanic currents, which are conducted through the dynamometer.

Measuring the intensity of galvanic currents, which are conducted through the dynamometer, would have been easily effected by means of a so-called sine- or tangent-

galvanometer adapted for fine measurements, if it had been installed at a greater distance from the dynamometer, and the same current which passed through the dynamometer, had also been conducted through the multiplier of that galvanometer. This shunting of the galvanic current can be dispensed with when one places a small (transportable) magnetometer in the magnetic meridian of the dynamometer at a distance from the dynamometer such that the dynamometer's fixed coil itself induces a deflection of the magnetometer which can be measured by fine fractions. It is obvious that at such a slight distance, the use of a large magnetometer (with a 600-millimeter-long needle) would be unsuitable, since in the case in question, it was a fundamental advantage to confine the distribution of the magnetism in the magnetometer to the smallest space possible. This occurred with the small or transportable magnetometer, which I have described in the "Resultaten aus den Beobachtungen des magnetischen Vereins im Jahre 1838" ("Results from observations by the Magnetic Society in 1838").

I have, however, contrived another instrument which suited this purpose still more fully, and will describe it here, because not only can it often replace the transportable magnetometer to advantage, but it provides for other purposes, especially thermo-magnetic measurements, an instrument which is often more precise than those previously applied. The advantages are well-known of using for such measurements a needle equipped with a mirror, along with a telescope and scale, instead of the compass with pointer and graduated scale. Yet using the mirror with small needles is risky, because the mirror is an inertial mass, which must be drawn along with the needle, and consequently, when a small needle has to draw a larger mirror along with it, the force of acceleration is greatly weakened, which is just as disadvantageous for the precision of the measurements to be made with the needle, as if a weakly magnetized needle were used. This disadvantage, however, can be removed from the outset if a *magnetic mirror* is employed, and this mirror is suspended by a silk thread as itself a magnetic needle. I have obtained such a mirror from the instrument-maker Mr. Oertling in Berlin. It consists of a tempered round steel plate *ab* (Figure 7), 33 millimeters in diameter and 6 millimeters thick. This steel plate is ground so completely smooth, that the mirror image of a scale appears very bright and clear through a telescope of tenfold magnification, and is little inferior to the image in a glass mirror. At the edge of this circular disc, small screw-threads are tapped at two diametrically opposed points, *a* and *b*, into each of which a little brass eyelet can be screwed, from which the mirror is hung with a silk thread. Only one of these threads is actually used, but soon the one, soon the other, according to whether the steel plate is to turn its mirror surface toward east or west. Now, I magnetized this tempered steel plate, by placing two 25-pound magnetic rods in a straight line one behind the other, but in such a way, that there remained an interval of space, equal to the diameter of the mirror, between the south and north poles of the two rods, the poles being turned toward each other. The mirror was placed in this space, so that that diameter of the mirror which was perpendicular to the line connecting the two eyelets, *a* and *b*, linked the two magnets. Given the strength of the magnets and the smallness of the mirror, this sufficed to impart to the mirror the maximum magnetism it was capable of assuming.

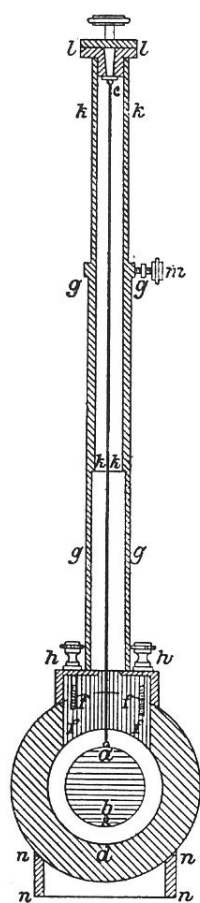

Fig. 7.

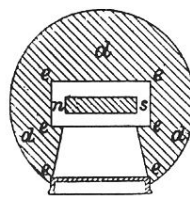

Fig. 8.

This magnetic mirror was suspended by a silk thread *ac* (Figure 7) and made to oscillate. The arc of the oscillation decreased only very slowly, so that the oscillations could still be observed after a quarter of an hour, without the mirror having received any new impetus in the meantime. The period of its oscillations, however, was too small for the observational series to be carried out according to the rules for larger magnetometers, as the maximum and minimum of the curve of oscillation was repeatedly observed right after one another. In order to make precise observations of the average position of the mirror, it was an essential requirement that the oscillations of the mirror be powerfully damped and the mirror brought to a complete halt in the shortest possible time, without exerting any sort of influence on the position of the mirror itself. I completely satisfied this essential requirement for using this sort of magnetic mirror, by constructing a solid copper sphere *ddd* (Figure 8) of 90-millimeter diameter. Into one side, a hole *eeee* of 40-millimeter diameter was drilled 70 millimeters deep into this sphere, and this hole could be closed with a flat glass pane. This hole was somewhat enlarged at its back end for the magnetic mirror, and was also enlarged in the form of a funnel toward the exterior, in order to give the mirror more access to the light. In the enlarged back space *eeee* was suspended the magnetic mirror, which can be seen in Figure 8 in the horizontal rectangular cross-section *ns*. From above, an 8-millimeter-wide, 40-millimeter-long opening *ffff* (Figure 7) led to this enlarged space, through which the mirror, suspended from a silk thread, could be let down to the center of the sphere. The silk thread was led through a brass tube *gggg*, whose lower end was screwed to the sphere, with the help of a brass plate *hh*, which covered the mouth of the opening *ff* to the sphere. Inside this brass tube was a

second exit-tube *kkkk*, which bore on its upper end a rotatable torsion circle *ll* with a hook, at *c*, to which the silk thread was tied. The thread could be raised through the exit tube, until the mirror swung freely in the center of the copper sphere. Then the exit tube was fixed in place by means of a push-screw *m*. To fix this copper sphere in place, a simple copper ring *nnnn* was installed, 20 millimeters high, of 70-millimeter diameter, and 2 millimeters thick, which formed a base into which the copper sphere was put. To level the instrument, a small box-level was placed on the torsion circle and the copper sphere was rotated in the ring until the level showed the correct alignment, which had to be carried out with great delicacy and precision. Owing to its great weight, the copper sphere lay so tightly in the ring, that no disturbance was ever noted.

The effect of this strong copper sphere on the oscillating mirror now consists in a *magneto-electric* damping, in virtue of which the preceding arc of oscillation was in the ratio to the succeeding one of 11 : 7 (the *decrementum logarithmicum* was = 0.19697), so that after 16 oscillations or about 1 minute (the period of oscillation was 3.78 seconds for this damping), the arc of oscillation was only about 1/1400 its original size, thus negligible. As a rule, given constant currents, it thus suffices to let 1 minute pass after the current begins, before one observes the deflected position of the mirror.

If such deflection experiments possess not merely a relative, but an absolute, value, then, according to the instructions given by Gauss in the *Intensitas vis magneticae terrestres ad mensuram absolutam revocata*,⁴ the deflecting magnet or current must at most be placed at a distance 3 or 4 times that of the needle's length, for which in our case the triple or quadruple of the mirror diameter will be 105 to 140 mm, at which slight distance even very weak currents of the multiplier suffice to elicit sharp measurable deflections of the mirror. If now 105 or 140 mm would be a distancing of the multiplier, sufficient to give an absolute value to the measurement of the deflection, then this would take place still more, by far, at a distance of 583.5 mm, at which the multiplier was placed from the mirror in our experiments. The mutual position of the two instruments, the dynamometer and the mirror magnetometer, is presented in Figure 9, where the dotted line *NS* is the magnetic meridian, which goes through both instruments: *A* is the horizontal cross-section of the dynamometer, as in Figure 4; *B* is the horizontal cross-section of the mirror magnetometer, as in Figure 8, *CD* are the telescopes for readings, aimed at the mirrors of both instruments; *EF* are the attached scales, whose mirror-image is observed. The use of the mirror magnetometer for thermo-magnetic observations, in which some additional devices come into play, will be treated on another occasion.

⁴ [N. E.] This paper by C. F. Gauss has already been translated to English: "The intensity of the Earth's magnetic force reduced to absolute measurement," translated from the German by Susan P. Johnson, July 1995, available in: <http://www.21stcenturysciencetech.com/>

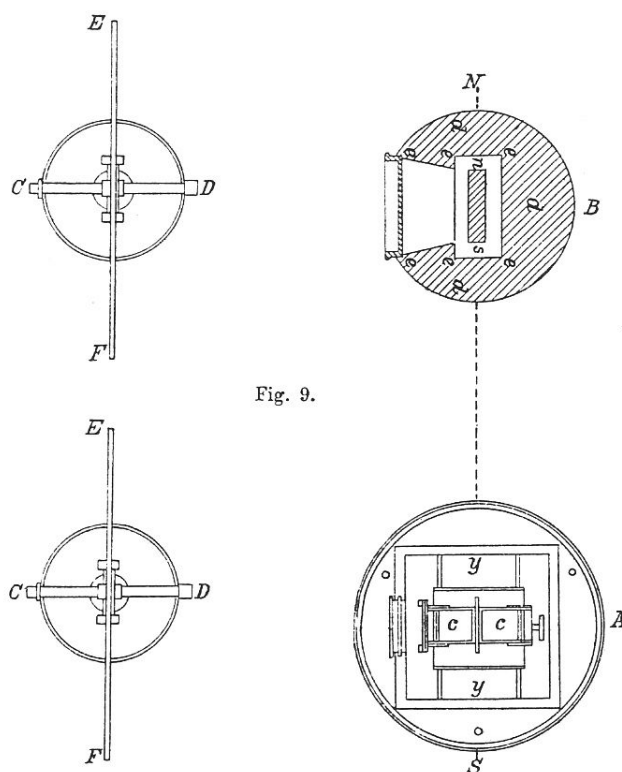

Fig. 9.

4.

After this description of the essential equipment, which was designed for *electromagnetic* measurement of the intensity of currents and for *electrodynamical* measurement of the reciprocal action of two portions of the circuit, and before we proceed to a description of the experiments themselves, we wish to make a prefatory remark about the elicitation and regulation of the currents which were used in those experiments.

Three small Grove's elements from the instrument-maker Mr. Kleinert were used, which were brought into the circuit, either all three, or only two, connected column-wise in series, or individually. Despite the fact that the currents were conducted through a very long, thin wire circuit, which formed the bifilar coil and the multiplier of the dynamometer, and which was even further extended by means of a long auxiliary wire, these currents, even given the great weakening which they underwent because of the great resistance of such a circuit, remained much too strong and deflected the dynamometer from its equilibrium position much too far, for this deflection to be measured by means of the 1-meter long scale. On the other hand, the intensity of these currents in the multiplier was quite suitable for eliciting a rigorously measurable deflection of the mirror magnetometer. Hence the deflection of the bifilar coil had to be diminished at a constant rate, without decreasing the intensity of the current in the dynamometer's multiplier. There were two ways for this to occur, either by increasing the separation of the suspension wires of the bifilar coil from each other, which would decrease the sensitivity of the dynamometer at a constant rate, or, the current could be apportioned so that only a small fraction of the current passing through the dynamometer, would be conducted through the bifilar coil. I preferred the latter method, in order to maintain the dynamometer's sensitivity, which was necessary for other experiments. A step or bridge was constructed for the current, by means of a short, thick copper wire, designated vv' in Figure 2, by which the current, outside the bifilar coil, was conducted directly to the wire returning

back out of the bifilar coil before the current entered the bifilar coil. A precise comparison of the resistance of this connecting wire with that of the bifilar coil, yielded the ratio

$$1 : 245.26,$$

from which it follows, according to Ohm's law, that the current intensity in the bifilar coil after this apportionment stood in the constant ratio of⁵

$$1 : 246.26$$

to the current intensity in the multiplier of the dynamometer, by means of which, thusly, without decreasing the deflection of the mirror magnetometer by the dynamometer's multiplier, the deflection of the dynamometer itself was diminished 246.26-fold. This 246.26-fold diminished deflection of the dynamometer could then be rigorously measured on the scale; the current might come from 3, 2, or only 1 Grove's element.

The measurements contained in the following table were made in that way.

⁵ [N. A.] For if a denotes the intensity of the completely unapportioned current, as it passes through the multiplier, b and c the intensity of the two currents, into which each divides itself, b passing through the bifilar coil, c through the auxiliary wire vv' which connects the beginning and the end of the bifilar coil; then $a = b + c$, and according to Ohm's law, the intensities $b:c$ are related inversely to the measured resistances, that is,

$$b : c = 1 : 245.26;$$

consequently

$$b : a = b : (b + c) = 1 : 246.26.$$

<i>Table of corresponding positions of the Mirror Magnetometer and the Dynamometer under the influence of currents of different intensity.</i>			
No.	Number of Grove's elements	Observed Position of Magnetometer	Observed Position of Dynamometer
1.	3	388.17	650.88
2.	0	279.74	209.79
3.	3	388.30	650.66
4.	0	279.68	209.47
5.	3	388.37	650.07
6.	0	280.05	209.70
7.	3	388.73	649.84
8.	0	279.95	209.55
9.	3	388.35	649.78
10.	0	279.78	209.53
11.	3	388.30	649.71
Average deflection	3 – 0	108.566	440.508
12.	0	279.54	209.25
13.	2	352.15	407.52
14.	0	280.00	208.99
15.	2	352.35	407.35
16.	0	280.00	208.82
17.	2	352.50	407.18
18.	0	280.15	208.87
19.	2	352.60	407.15
20.	0	280.17	208.92
21.	2	352.95	406.89
22.	0	280.40	208.80
Average deflection	2 – 0	72.438	198.305
23.	0	280.40	208.80
24.	1	316.77	259.68
25.	0	280.50	208.72
26.	1	216.93	259.53
27.	0	280.60	208.68
28.	1	316.90	259.50
29.	0	280.50	208.45
30.	1	316.85	259.38
31.	0	280.60	208.43
32.	1	216.90	259.35
33.	0	280.55	208.33
Average deflection	1 – 0	36.332	50.915

The following explanations should be appended to this table: 1.) During all these experiments, the relationships of the conductors always remained the same, so that the conditions of current intensity in all portions of the circuit were always the same. 2.) The corresponding observations on the magnetometer and dynamometer were always carried out simultaneously by two different observers at both instruments. The observers were, in addition to myself, Dr. Stähelin

from Basel, and my assistant Mr. Dietzel. 3.) Every single dynamometer observation shown in the table is not a simple reading, but each such observation is based on 7 readings: namely, as the oscillation occurred, the highest and lowest position were alternately read and the 6 averages from each two successive readings taken to begin with; the 5 second averages, taken in turn from two such successive averages, were considered as partial results, and the average value of these 5 partial results entered in the table. 4.) Between every two observations of the deflected position, the circuit was broken, in order to observe the natural position without galvanic influence, because this position changes appreciably, though very slowly, over time. This breaking of the circuit is indicated by a zero in the column which shows the number of elements. 5.) The average values of the deflection for the observations in the table from 1 to 11 are derived from the 11 preceding observations, by taking the 10 differences from each two successive observations during the closed and broken circuit, and the 9 averages were taken from every second such initial successive difference, of which, as a partial result, the overall average is given in the table. 6.) Finally, as for the magnetometer, the horizontal distance of the mirror from the scale is to be noted during the experiments contained in this table, because it later had to be frequently altered: it amounted to 1,251 scale units. 7) The 11 observations, from which the average deflections of the magnetometer and dynamometer were calculated, give a proof of the exactness of the measurement; for one sees, that the 5 or 6 repetitions of the experiments, with the circuit closed and broken, which the 11 observations comprise, always agree, up to a fraction of a scale unit, in which connection it is to be noted, that even these small differences originate for the most part in the actual changes in current intensity; further, in the case of the magnetometer, they originate in the variations in declination appearing during the experiment; and, in the case of the dynamometer, from a placement which was not perfectly fixed and invariable.

The results of all these experiments can be briefly surveyed in the correlated average values of the deflection of the magnetometer and dynamometer by the current of 3, 2, and 1 Grove's elements, namely:

	Average deflection of magnetometer	Average deflection of dynamometer
for 3 elements	108.566	440.508
for 2 elements	72.438	198.305
for 1 element	36.332	50.915

According to the optical law of reflection, these numbers are proportional to the tangent of the doubled angle of deflection and are to be reduced to the tangents of the simple angle of deflection, which give the measure of the deflecting forces, in which a small influence on the part of the eccentricity of the mirror is to be taken into consideration. The corrections emerging from this are:

0.14	0.47
0.04	0.05
0.00	0.00,

from which, if these corrections are taken into account, the following corrected values are yielded, i.e., for the deflecting force

of the magnetometer	of the dynamometer
108.426	440.038
72.398	198.255

36.332	50.915.
--------	---------

Now, according to the measure of *electromagnetic* intensity taken above as the foundation, the numbers in the *first* column are proportional to the *current intensity*, while the numbers in the *second* column give the corresponding *electrodynamic forces*, according to which, therefore, the dependency of the electrodynamic forces on the current intensity can be determined, which was the chief purpose of these experiments. Before this occurs, however, let it be noted, that it could seem as though a small extraneous influence must still be excluded from the numbers in the first column, i.e., that which originates from the influence of the *bifilar coil* on the magnetometer. That is, those numbers, then, could only hold true as a measure of current intensity, if the magnetometer is always deflected by that same fixed, uninterrupted segment of the circuit. This segment of the circuit was the uninterruptedly fixed multiplier of the dynamometer. In point of fact, this multiplier was located in a position vis-à-vis the magnetometer, such that it exerted the greatest deflecting force, while the bifilar coil suspended in the multiplier was brought originally into such a position, where, even if a stronger current was conducted through it, it was able to exert no deflecting force whatever. Now, however, in the foregoing experiments the bifilar coil was appreciably deflected or twisted, and after this twisting, it had to exert a deflecting force on the magnetometer, wherefore the numerical values above required a correction, in order to make them correspond to the exclusive influence of the multiplier. This correction is, however, merely very small, because the intensity of the current passing through the bifilar coil amounted to only a 246.26th of the current intensity in the multiplier, because of the separation [of the current] mentioned above. I have ascertained for myself, that even in the case where the correction was greatest, it still remained below 1/500 scale units, and hence can be disregarded.

If one now multiplies the square roots of the observed values for the electrodynamic reciprocal action, namely, $\sqrt{440.038}$, $\sqrt{198.255}$, $\sqrt{50.915}$, by the constant factor

$$5.15534,$$

one obtains nearly the observed values for the electromagnetic effect, namely, the series:

$$108.144$$

$$72,589$$

$$36,786,$$

whose comparison with the observed values yields the following differences:

$$- 0.282$$

$$+ 0.191$$

$$+ 0.454.$$

The greatest difference, which appears between these calculated values and the directly observed values for the electromagnetic force, thus amounts to less than half a scale unit, in virtue of which, the law underlying the calculation can be considered as proven, *that the electrodynamic force of two portions of a circuit is proportional to the square of the electromagnetic force, consequently proportional to the square of the current intensity.*

This experiment also makes it evident, that the method of electrodynamic measurement utilized here permits a rigor and precision almost equal to that permitted by the method of magnetic measurement with the magnetometer.

5.

Proof of the fundamental electrodynamic law by means of measurement.

After this first test of the precision to be achieved with the described instruments of electrodynamic measurement, I proceed at once to a system of the measurements carried out then, which is suited to a complete examination of the fundamental electrodynamic law.

Ampère, in his Treatise cited above, page 181 f., presents two methods of deriving the law of reciprocal action of two conducting wires from experimentation. “The one way,” he says, “consists of first measuring with the utmost precision the values of the reciprocal action of two pieces of finite size, by successively bringing them at different distances and positions vis-à-vis each other; then one must make a hypothesis about the value of the reciprocal action of two infinitely small parts, conclude from this the value of the [reciprocal] action, which emerges for the conductors of finite size, with which one has operated, and modify the hypothesis, until the results of the calculation agree with those of observation.” ... “The other consists of experimentally confirming, that a moveable conductor stays in perfect equilibrium between equal forces or equal rotational moments,⁶ when these forces or moments come from parts of fixed conductors, whose shape and size can be altered in any way whatever, under conditions, determined by the experiment, without disturbing the equilibrium, and from this to directly conclude by means of calculation, what the value of the reciprocal action of two infinitely small parts must be, in order that the equilibrium may be actually independent of all changes of form or size, which are compatible with those conditions.”

Ampère preferred the latter method for reasons among which one was already sufficient, namely that he did not possess the instruments indispensable for the former method. Of course, under such conditions the second method had to be preferred, which does not require the performance of actual measurements. Yet Ampère seems to have overvalued the latter method, when he expressed the view that it deserved an absolute preference over the former. An instrument for precise measurements has two prerequisites: 1.) a great refinement and sensitivity, which allows us to recognize the effects to be measured clearly and independently of extraneous, uncontrollable influences; 2.) a measuring apparatus suited to these effects. It is clear, however, that this latter requirement can always be easily fulfilled, if the former is satisfied, thus the former must be regarded as the main requirement. Fulfillment of this main requirement, however, is just as essential for the second method as for the first, because otherwise it will be quite illusory. The essential difference between these methods, in relation to experimentation, is thus simply that according to the former method, one holds the equilibrium of the electrodynamic forces by means of other known and measurable forces of nature, while according to the second method, one seeks conditions in which the electrodynamic forces will mutually maintain the equilibrium between themselves. There can be no doubt, that the latter method, if it is to lead to reliable and precise results, is less direct and less simple, in the *experimental* connection, than the former. Hence, at most, the fact can be brought to bear in favor of the second method, that in the *theoretical* connection, the fundamental law can be more easily and more directly derived from the results achieved by this method, which, however, is no longer a consideration, if the fundamental laws to be tested are already fully in hand, as occurs, through Ampère's services, in the foregoing case. In virtue of this, we are in a position to carry out a very simple system of measurements, which meets the requirements.

The two conducting wires, which act reciprocally upon each other, should form circles, or systems of parallel circles, which have a common axis and are called *conducting coils*. These two axes should have a position horizontal and right-angled to each other, specifically, so that the extension of the one axis goes through the center of the other coil. One of these coils is fixed, the other can be rotated around its vertical diameter. Now, either the extended axis of the fixed coil can go through the center of the moveable coil, or, vice versa, the extended axis of the moveable coil

⁶ [N. E.] In German: Drehungsmomenten. This can also be translated as rotatory actions or torques.

can go through the center of the fixed coil. In both cases, one can make measurements at different distances of the centers from each other. It is easily seen, that these two ways of ordering electrodynamic measurements fully correspond to those of the magnetic measurements, which Gauss has presented in the *Intensitas vis magneticae terrestris ad mensuram absolutam revocata* (Commentationes Soc. regiae Scient. Gottingensis recentiores, Vol. VIII, page 33⁷). For the electrodynamic reciprocal actions, we can add still a third ordering of measurements, where the centers of the two coils coincide, as occurs in the dynamometer described above. In all these cases, Ampère's law can be applied, and the results calculated, in order to compare them with the results of observation.

If the fixed coil acts at a distance on the moveable coil, then the two coils can have arbitrarily like or unlike diameters; if, however, the centers of the two coils are to coincide, as was the case with the measuring instruments described above, then the interior diameter of the one, ring-shaped coil must be larger than the exterior diameter of the other, so that the former can contain the latter. In the dynamometer described above, the moveable coil was the smaller, and was contained by the fixed coil. If, finally, the three series of experiments just indicated are to be carried out, by simply placing the fixed coil in different places in succession, without changing the suspension of the moveable coil, which is advantageous for more precise comparison of all the measurement results with each other, then the moveable coil must be larger, so that it can contain the fixed coil, because that is the only way the latter, unimpaired by the suspension wires, can be introduced through the moveable coil. This is the reason why, for this system of measurements, a special measuring apparatus was constructed by the instrument-maker Mr. Leyser in Leipzig, which will be described here.

The *bifilar coil aaa* in Figure 10 consists of a thin brass ring of 100.5 mm diameter and 30 mm high, which lies between two parallel brass discs or washers of 122.7 mm exterior diameter and 100.5 mm interior diameter, and holds them at a distance of 30 mm from one another. A copper wire of 1/3 mm diameter, coated with silk, is wound around that brass ring/cylinder about 3,000 times, between these two discs, so that it entirely fills up the space between the two discs. After the wire is wound, the two brass discs are held together by a fixed brass clamp *bb*, which encloses the wound wire and holds up the torsion-circle at its center. The torsion-circle consists of two horizontal (when the bifilar coil is situated vertically) discs, of which the lower is rigidly connected by means of the brass clamp to the bifilar coil, while the upper can rotate on the lower around a vertical axis. The upper disc is furnished with a circular scale of units, the lower with an index. On the upper disc rests a wooden peg *d*, which at the upper end holds the prong *ee* of a very moveable roller of 20 mm diameter. A silk thread *ff* is led around this roller, passes vertically upward over both sides of the roller, and is fastened on both sides, a few millimeters above the roller, to the two suspension wires *fg* and *fg*. To these connection-points *f* and *f*, the two ends of the wire wound around the bifilar coil are also brought, in such a way that the galvanic current can be conducted through the one suspension wire to one end of the bifilar coil, and out the other end of the bifilar coil into the second suspension wire. The two suspension wires go upward from these connection-points vertically toward the ceiling, where they are fastened to two brass hooks insulated from one another. From these two hooks, two other wires are led away, one to a commutator, the other to the galvanic battery.

⁷ [N. H. W.] Gauss, *Werke*, Vol. V, page 107.

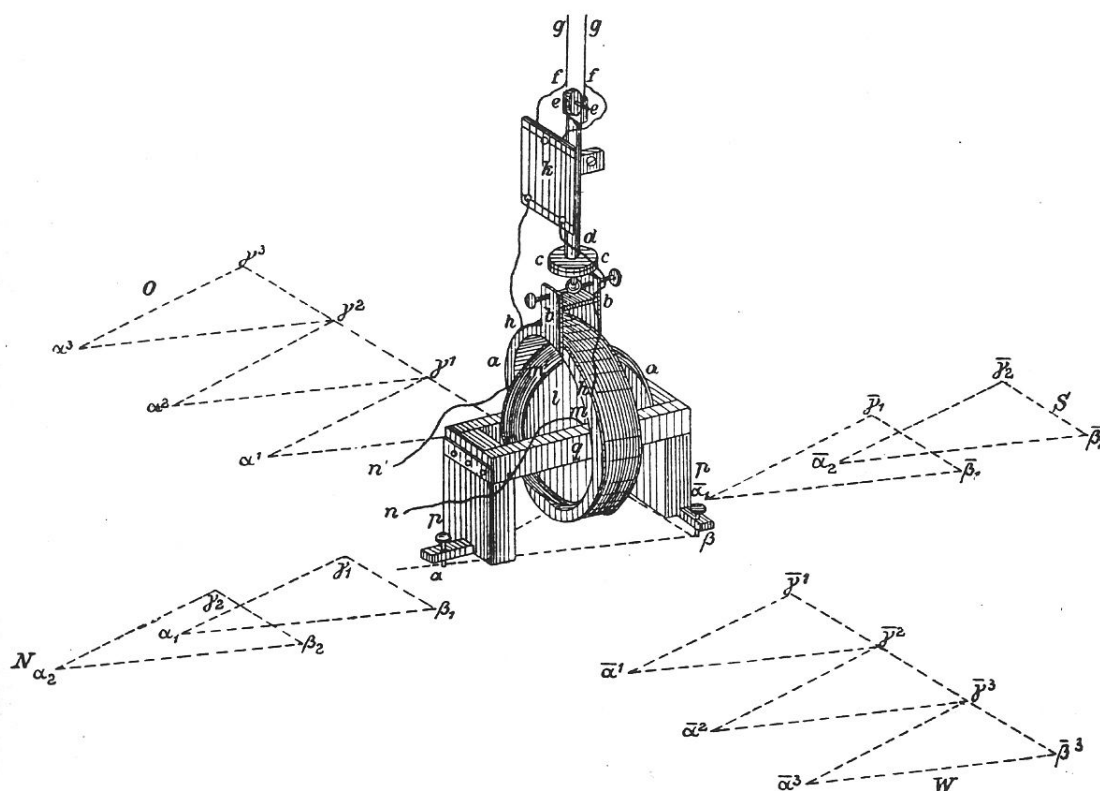

Fig. 10.

With the help of the torsion-circle, one can give the horizontal axis of the bifilar coil any arbitrary position, while the suspension wires maintain their natural parallel position. The torsion-circle was adjusted in such a way, that the axis of the bifilar coil coincided with the magnetic meridian NS , so that the terrestrial magnetism did not alter the position of the bifilar coil, when a galvanic current passed through the coil.

To the wooden peg on the torsion-plate a vertical flat mirror k was fastened, at which at about a 3.3 meter distance, a telescope with crosshairs was directed, in order to observe the image of a horizontal scale set up near the telescope.

The *fixed coil III* in Figure 10 consists of two thin parallel brass plates of 88.8 mm diameter, which are held in a fixed position 300 mm distant from each other by a 5.5 mm thick brass axle m . This brass axle goes through both plates and extends 10 mm on both sides. Around the same axle between the two discs, a copper wire of 1/3 mm diameter, sheathed in silk, is wound roughly 10,000 times, so that it entirely fills the space between the two discs. One end of this wire is led outward, close to the axle, through a small opening lined with ivory at m in the one disc, from m to n ; the other end is fastened to the periphery of the coil at m' with silk thread and goes outward from m' to n' . The one wire end $n'n'$ is brought to the commutator A (Figure 11), the other nn to the multiplier B (Figure 11) of a galvanometer.

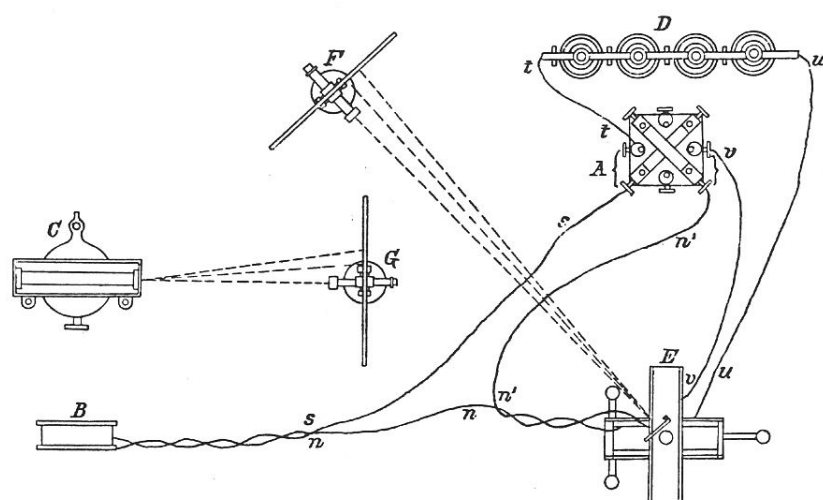

Fig. 11.

A small wooden stand pp serves to keep this coil fixed (Figure 10), which presents two sockets q , into which the two protruding parts of the axle are laid. This stand stands on three feet which are fitted with screw-tips α , β , γ for levelling. One of these feet is fitted with a hinge r , and can be pushed open in such a way that one can freely move it, along with a part of the stand and of the fixed coil, through the bifilar coil, and then can push it down again. The fixed coil then comes to stand in the center of the bifilar coil, and the stand then rests with two feet on this side of the bifilar coil, and with the third foot on that side, on the immovable table, which is close below the bifilar coil.

On the flat horizontal table-top, the positions are precisely drawn ahead of time, at which the fixed coil is to be successively placed. Namely, the three screw-tips, which, with concentric placement of the two coils, stand on points α , β , γ of the table-top, are shifted in such a way that they come to stand either *north* at points $\alpha_1\beta_1\gamma_1$ or $\alpha_2\beta_2\gamma_2$ and so on, or *south* at points $\bar{\alpha}_1\bar{\beta}_1\bar{\gamma}_1$ or $\bar{\alpha}_2\bar{\beta}_2\bar{\gamma}_2$ and so on, or *east* at points $\alpha^1\beta^1\gamma^1$ or $\alpha^2\beta^2\gamma^2$ and so on, or *west* at points $\bar{\alpha}^1\bar{\beta}^1\bar{\gamma}^1$ or $\bar{\alpha}^2\bar{\beta}^2\bar{\gamma}^2$ or $\bar{\alpha}^3\bar{\beta}^3\bar{\gamma}^3$ and so on. For protection against the influence of the air, the bifilar coil is surrounded with a wooden casing, in which a glass sheet is inserted, through which the light can fall from the scale onto the mirror, and thence back into the telescope. The casing consists of two parts, one of which can be removed when the fixed coil is to be placed in the center of the movable coil.

In order, now, to make the system of electrodynamic measurements carried out with this instrument comparable among themselves, it was necessary to measure, independently of the system, the intensity of the current which was conducted through the two coils during each measurement. For this purpose, the apparatus described in Section 3 could not be applied, because of the adjustment of the fixed coil to be undertaken from one measurement to another. Hence the one end nm of the wire wound around the fixed coil was connected to a third wire coil B (Figure 11), which consisted of 618 parallel windings, enclosing an area of 8,313,440 square millimeters, and was placed 217 mm west of a transportable magnetometer, C , 8 meters away from the dynamometer (Figure 11), and which with the magnetometer formed a *galvanometer*. With its other end ss , this third wire coil was, finally, connected with the commutator A (Figure 11), to which one conducting wire tt of the galvanic battery D also led.

Figure 11 gives a clear representation of the ordering and connection of the different parts of the apparatus. It may be noted in this connection, that the two wire ends of the fixed coil, when

they were located close to the bifilar coil, were wound around each other in such a way that the opposite currents passing through them had no influence on the bifilar coil. *E* represents the dynamometer in outline, *F* the accompanying telescope for the readings, along with the scale; *C* represents the magnetometer in outline, and *G* the accompanying telescope for the readings, along with the scale; *B* is the multiplier coil through which the same galvanic current is conducted as through the dynamometer, and which acts at a distance on the needle of the magnetometer *C*, whose deflection from the magnetic meridian is measured, in order to determine the intensity of the applied current and its variations during the experiments.

The galvanic battery, which was used for these experiments, consisted of 8 Bunsen carbon elements. The direction of this current always remained the same in the wire of the bifilar coil of the dynamometer *E*, and was, as is clear from the placement of the commutator *A*, reversed in the fixed coil of the dynamometer *E* and in the third coil *B*, which took the place of the multiplier in the *galvanometer*, simply by means of the alternation of the commutator. It was necessary for the current in the bifilar coil to maintain its constant direction, in order to eliminate the influence of terrestrial magnetism. The reversal of the current in the fixed coil was necessary, in order to deflect the north end of the axis of the bifilar coil alternately eastward and westward by means of the effect of this fixed coil on the bifilar coil, and, through repeated measurement of these positive and negative deflections, to determine this effect with greater rigor. The reversal of the current in the third coil had the same purpose, in relation to the deflection of the magnetometer, which served to determine the current intensity. This purpose is attained by means of the equipment described, with the help of the commutator *A*; for the direction of the current constantly remained the same in the battery *D* and in all those portions of the circuit which the battery *D* connects with the commutator *A*, namely, in the wire *tt*, in the battery *D*, in the wire *uu*, in the *bifilar coil* of the dynamometer *E* and in the wire *vv*; on the other hand, the direction of the current can be changed by the commutator *A* in all those portions of the circuit which are separated by the commutator *A* from the battery *D*, namely, in the wire *n'n'*, in the *fixed coil* of the dynamometer *E*, in the wire *nn*, in the multiplier coil *B*, and in the wire *ss*.

The period of oscillation of the bifilar coil without current was = 13.3259". The horizontal distance of the mirror of the bifilar coil from the scale was 3,306.3 scale units; the horizontal distance of the magnetometer's mirror from the scale was 1,103 scale units. The results of these measurements are contained in the following table, in the same order in which they were made.

<i>A</i>	Dynamometer			Galvanometer		
600 westerly	516.27			250.47		
		26.41			321.49	
	542.68			571.96		
		26.74			321.48	
	515.94			250.48		
		26.37	26.35		321.12	320.14
	542.31			571.60		
		26.24			319.41	
	516.07			252.19		
		26.00			317.22	
	542.07			569.41		
500 westerly	506.37			254.05		
		44.47			314.65	
	550.84			568.70		
		44.87			314.22	
	505.97			254.48		
		43.89	44.31		314.77	314.32
	549.86			569.25		
		44.50			314.33	
	505.36			254.92		
		43.84			313.63	
	549.20			568.55		
500 northerly	517.27			566.80		
		20.34			312.08	
	537.61			254.72		
		20.43			312.98	
	517.18			567.70		
		20.19	20.30		312.82	312.48
	537.37			254.88		
		20.36			312.63	
	517.01			567.51		
		20.19			311.89	
	537.20			255.62		
500 easterly	505.06			257.92		
		43.04			308.39	
	548.10			566.31		
		43.09			308.98	
	505.01			257.33		
		42.53	42.89		308.05	308.80
	547.54			565.38		
		42.32			309.09	
	505.22			256.29		
		43.46			309.50	
	548.68			565.79		

<i>A</i>	Dynamometer			Galvanometer		
500 southerly	517.96			564.05		
		19.51			306.09	
	537.47			257.96		
		19.80			306.07	
	517.67			564.03		
		19.19	19.49		305.14	305.56
	536.86			258.89		
		19.79			305.47	
	517.07			564.36		
		19.17			305.03	
	536.24			259.33		
600 easterly	514.31			260.23		
		24.19			304.46	
	538.50			564.69		
		23.65			305.02	
	514.85			259.67		
		24.06	23.72		304.58	304.92
	538.91			564.25		
		23.72			305.36	
	515.19			258.89		
		23.85			305.17	
	539.04			564.06		
400 easterly	568.21			562.50		
		81.67			303.54	
	486.54			258.96		
		81.85			304.67	
	568.39			563.63		
		81.77	81.64		303.35	303.79
	486.62			260.28		
		81.57			303.32	
	568.19			563.60		
		81.35			304.08	
	486.84			259.52		
400 northerly	546.32			261.44		
		36.27			300.95	
	510.05			562.39		
		36.25			302.42	
	546.30			259.97		
		36.14	36.15		302.73	302.07
	510.16			562.70		
		35.96			301.58	
	546.12			261.12		
		36.12			302.69	
	510.00			563.81		

<i>A</i>	Dynamometer			Galvanometer		
400 westerly	488.36			261.99		
		79.71			300.99	
	568.07			562.98		
		79.78			301.45	
	488.29			261.53		
		79.60	79.60		300.97	300.80
	567.89			562.50		
		79.49			300.80	
	488.40			261.70		
		79.40			299.83	
	567.80			561.53		
400 southerly	510.23			561.18		
		35.34			298.95	
	545.57			262.23		
		35.53			299.67	
	520.04			561.90		
		35.45	35.43		299.40	299.30
	545.49			262.50		
		35.56			299.37	
	509.93			561.87		
		35.28			299.11	
	545.21			262.76		
300 southerly	566.29			263.73		
		79.48			298.81	
	486.84			562.54		
		79.39			300.31	
	566.23			262.23		
		78.13	78.85		300.30	299.89
	488.10			562.53		
		78.64			300.30	
	566.74			262.23		
		78.62			299.71	
	488.12			561.94		
300 westerly	431.18			263.96		
		192.57			298.05	
	623.75			562.01		
		192.40			298.25	
	431.35			263.76		
		192.20	192.17		297.99	297.81
	623.37			561.75		
		191.96			297.30	
	431.41			264.45		
		191.91			297.45	
	623.32			561.90		

<i>A</i>	Dynamometer			Galvanometer		
300 northerly	566.96			265.93		
		78.30			297.12	
	488.66			563.05		
		78.37			299.13	
	567.03			263.92		
		77.93	78.08		299.12	298.33
	489.10			563.04		
		77.98			298.15	
	567.08			264.89		
		77.80			298.14	
500 easterly	433.52			266.49		
		190.26			296.69	
	623.78			563.18		
		109.43			298.16	
	433.35			265.02		
		190.23	109.08		296.98	297.30
	623.58			562.00		
		189.89			297.09	
	433.69			264.91		
		189.59			297.60	
	623.28		562.51			

The following explanations are to be appended to the table. In column *A*, the distance between the centers of both coils of the dynamometer is given in millimeters, and it is noted, in which direction, taking the bifilar coil as the point of origin, the fixed coil was placed; under north and south, the direction is to be understood as aligned with the magnetic meridian; under east and west, the direction is to be understood as perpendicular to the magnetic meridian. – In the second column, headed “Dynamometer,” the position of the bifilar coil is given in scale units, alternating between the direct and reversed direction of the current in the fixed coil. Each of these numbers is based on 7 readings, in which from oscillation to oscillation, the maximum and minimum of the oscillation arc were alternately taken 7 times after one another, and from this, according to recognized rules, the average state of equilibrium of the oscillating coil was calculated. With the reversal of the current in the fixed coil, a procedure was applied which did not increase the arc of oscillation of the bifilar coil. In the table, next to the observations of position, which relate alternately to the direct and reversed current in the fixed coil, are noted the differences for every second immediately successive observation, which provide in scale units the double deflection of the bifilar coil by means of the influence of the fixed coil. Finally, next to these particular values of the double deflection, their average value for each placement of the fixed coil is noted. – In the third column, headed “Galvanometer,” the position of the galvanometer is given, alternately with direct and reverse current direction in the coil *B* serving as multiplier. This position has been observed and calculated in the same way as with the dynamometer, and next to it are noted the differences and the average value of the double deflection of the galvanometer. The corresponding observations at the dynamometer and at the galvanometer were always made simultaneously by two observers at the two instruments.

All the observations assembled in the table above were made in the order presented, on one day, immediately after one another, and, since all external conditions remained exactly the same, all the results are directly comparable with one another. On this day, it had not been possible to carry out as well those observations, whereby the fixed coil received its placement in the center of the bifilar coil, because the re-positioning of the fixed coil required several time-consuming precautionary measures. This last series of experiments was hence postponed to the next day. However, because it was then no longer possible to be confident that all external conditions remained exactly the same as in the earlier experiments, on this second day, for comparison, two series of experiments, which had already been made on the first day, were repeated, namely, at a 300-mm east and west distance of the fixed coil from the bifilar coil, which could be used to reduce the last series of experiments in such a way, that the results became comparable with the results of the earlier experiments, independently of the small variations which might have occurred in the external conditions in the meantime. Also, the fact that on the next day, another galvanic battery was used, namely of 2 Grove (platinum-zinc) elements instead of 8 Bunsen carbon elements, had no influence on this comparison. This was necessary because otherwise, the deflection of the dynamometer when the fixed coil was placed in the center of the bifilar coil would have been too large to be measured on the scale. Finally, it may be noted that the constant direction of the current in the bifilar coil was the opposite on the next day from the first, which likewise had no influence on the reduced results. The results of this second series of experiments are contained in the following table.

<i>A</i>	Dynamometer			Galvanometer		
0	48.05			359.78		
		905.69			64.51	
	953.74			424.29		
		904.84			64.46	
	48.90			359.83		
		904.00	903.97		64.47	64.45
	952.90			424.30		
		903.01			64.40	
	49.89			359.90		
		902.31			64.39	
300 easterly	485.70			529.30		
		27.58			125.08	
	513.28			454.38		
		27.18			124.99	
	486.10			329.39		
		27.25	27.54		124.89	125.08
	513.35			454.28		
		28.26			125.10	
	485.09			329.18		
		27.43			125.35	
	512.52		454.53			
	512.37		454.50			
		25.65		125.18		
	486.72		329.32			
		27.77		125.29		
300 westerly	514.49			454.61		
		27.43	27.20		125.35	125.23
	487.06			329.26		
		27.60			125.30	
	514.66			454.56		
		27.55			125.05	
	487.11			329.51		

Herewith it is to be noted that the current of 2 Grove's elements also elicited a larger deflection of the dynamometer than could be measured with the 1,000-unit scale, when the fixed coil was placed in the center of the bifilar coil, and that therefore in this case the current was weakened through increasing the resistance of the circuit by inserting a long, thin conducting wire, which was removed again when the coils were placed 300 mm apart, because otherwise the deflection of the dynamometer would turn out to be too small for an exact measurement. This is discerned from the difference in the magnetometer deflection, which measures the current intensity, and in the latter case amounted to almost double that of the former.

The results of this series of experiments can easily be surveyed in the following compilation of all the average values of the simultaneous deflections of the dynamometer and galvanometer, namely:

Distance in mm	Dynamometer	Galvanometer
0	903.97	64.45
300 easterly	27.54	125.08
300 westerly	27.20	125.23.

These numbers are, according to the optical law of reflection, proportional to the tangents of the doubled angles of deflection, and are to be reduced to the tangents of the simple angles of deflection, because these will give the measure of the deflecting force. Here a slight influence of the eccentricity of the mirror is still to be taken into consideration. One obtains from this the following reduced values:

0	899.79	64.44
300 easterly	27.54	124.98
300 westerly	27.20	125.13.

We take the average from the last two series, which differ very little from one another, because they should be almost equal if the current intensity is the same and the position of the fixed coil easterly and westerly of the bifilar coil is totally symmetric, whereby we obtain the following values:

0	899.79	64.44
300	27.37	125.055

The results of the foregoing series of experiments can be surveyed in the compilation of all the average values for the dynamometer and galvanometer deflections in the following table:

Distance	Easterly		Westerly		Southerly		Northerly	
	Dynamo-meter	Galvano-meter	Dynamo-meter	Galvano-meter	Dynamo-meter	Galvano-meter	Dynamo-Meter	Galvano-meter
300	190.08	297.30	192.17	297.81	78.85	299.89	78.08	298.33
400	81.64	303.79	79.60	300.81	35.43	299.30	36.15	302.07
500	42.89	308.80	44.31	314.32	19.49	305.56	20.30	312.48
600	23.89	304.92	26.35	320.14	-	-	-	-

I have convinced myself, that the influence of the reduction of these numbers to the tangents of the simple deflection angles for the dynamometer is so slight, that it can be left out of consideration; that is, it is smaller than the unavoidable observational errors. This correction also comes into consideration in the galvanometer observations, because no large differences emerge in the deflection of the galvanometer.

6.

The observed electrodynamic forces in the foregoing Section can not immediately be used for the intended test of the dependence of these forces, determined by Ampère's law, on the mutual position of the conducting wires acting upon each other, because they are based on different current intensities. Hence these observations are first to be reduced to *the same current intensities*, for which the law proven in the fourth Section comes into application, according to which the

dynamometer deflections are proportional to the square of the galvanometer deflections. The application of this law to the observations at hand, however, itself presupposes another reduction, namely, the reduction *to the same directional force* of the bifilar coil, which underwent appreciable changes during these experiments. In the observational results presented in the fourth Section, through which the cited law was proven, the correction resulting from this was negligible and hence did not need to be taken into account, because there the current which passed through the fixed coil of the dynamometer, was divided, and only a small part, namely 1/246 of the entire current, was conducted through the *bifilar coil*, which had no appreciable influence on the directional force of this coil. With regard to the present observational results, on the contrary, this reduction cannot be ignored, because here the entirety of the current conducted through the fixed coil, went further through the bifilar coil.

The *directional force of the bifilar coil* separates into a *constant* and a *variable* component. The *constant* component, which is called the *static moment*, depends on the weight of the bifilar coil and on the length and distance of separation of the suspension wires, and can be calculated from the observed *period of oscillation* and from the *inertial moment* of the bifilar coil. The *period of oscillation* of the bifilar coil, if no current is passing through it, was determined by means of special observations,

$$t = 13.3259''.$$

The *inertial moment* K was found according to the formula given by Gauss in the *Intensitas*,

$$K = 864,800,000,$$

in which millimeters and milligrams are the basis for measuring length and mass. The *static moment* S is obtained from

$$S = \frac{\pi^2 K}{t^2} = 48,064,000.$$

The *variable* component of the directional force of the bifilar coil, which is called the *electromagnetic moment*, depends on the intensity of the horizontal component of the *terrestrial magnetism* T , on the intensity of the current of the bifilar coil, χ , and on the size of the area, λ , which is demarcated by the wire windings of the bifilar coil, and is to be set equal to the product of these three magnitudes. The intensity of the horizontal component of the terrestrial magnetism was found to be, at the location of the bifilar coil,

$$T = 1.83.$$

The size of the *area*, which was demarcated by the wire windings of the bifilar coil, could not be determined by direct measurement, because the number of wire windings was not precisely known. Hence this area was indirectly determined by comparison of the electromagnetic effect of this coil with that of another of known area on a distant galvanometers, by which

$$\lambda = 29,314,000 \text{ square mm}$$

was obtained. The *current intensities*, finally, were given for all individual experiments by means of the galvanometer observations in scale units, which nevertheless are to be reduced for present purposes to the *fundamental electromagnetic measure* of current intensity. To do this, the observed number of scale units is multiplied by a constant factor, which in accordance with the proof to be given in the ninth Section is to be

$$= 0.000\ 361\ 4.$$

Thus, if y denotes the number of scale units observed on the galvanometer, then the current intensity is

$$\chi = 0.000\ 361\ 4 \cdot y.$$

From these elements results the *electromagnetic moment* of the bifilar coil

$$\chi\lambda T = 19\ 400 \cdot y.$$

This value for the electromagnetic moment is to be subtracted, in the *first* series of experiments, from the *static moment*, in the second series of experiments, however, it is to be added to the static moment, in order to obtain the *directional force of the bifilar coil*, because, as already noted on page 29,⁸ the direction of the current in the bifilar coil in the last series was opposite to that in the first. For the *first* series of experiments, the directional force in units of static moment resulted as

$$= 1 - \frac{19\,400}{48\,064\,000} \cdot y,$$

for the second series of experiments

$$= 1 + \frac{19\,400}{48\,064\,000} \cdot y.$$

The observed *dynamometer deflections* are accordingly reduced to a constant directional force equal to the *static moment*, if one multiplies the number of scale units observed on the dynamometer x in the *first* series of experiments by $(1 - 194 \cdot y / 480\,640)$, in the *second* by $(1 + 194 \cdot y / 480\,640)$.

After performing this reduction, one obtains for the *first series* the values of the dynamometer and galvanometer deflections, assembled in the following table.

Distance	Easterly		Westerly		Southerly		Northerly	
	Dynamo-meter	Galvano-meter	Dynamo-meter	Galvano-meter	Dynamo-meter	Galvano-meter	Dynamo-meter	Galvano-meter
300	167.26	297.30	169.06	297.81	69.30	299.89	68.67	298.33
400	71.63	303.79	69.93	300.81	31.15	299.30	31.74	302.07
500	37.54	308.80	38.69	314.32	17.09	305.56	17.74	312.48
600	20.95	304.92	22.94	320.14	-	-	-	-

For the *second series* one obtains the following correlated values:

Distance	Easterly or Westerly	
Millimeter	Dynamometer	Galvanometer
0	923.19	64.44
300	28.75	125.055

The *sensitivity* of an instrument is inversely proportional to its *directional force*, i.e. the force to be measured generates an all the greater deflection, the smaller its directional force is. The foregoing observational data, reduced to *the same directional force*, are thus equivalent to those obtained under the condition of *equal sensitivity* of the dynamometer.

After this reduction of the dynamometer observations *to the same directional force*, it is now possible to bring into application the law proven in the fourth Section and to reduce all observations, for better comparison among themselves, *to the same current intensity*. For this, it is only necessary to determine more closely the normal current intensity for which the reduced observational data are supposed to be valid. Since it is not necessary to utilize for both series of experiments *equal* normal current intensities, that intensity may be chosen for the *first series* which corresponds to a galvanometer deflection in scale units, whose square = 100,000, for the *second series* a five-times-smaller one, for which this square = 4,000. According to the law proven in the fourth Section, one then obtains from the dynamometer deflection x , given in the table, which

⁸ [N. E.] Page 62 of Weber's *Werke*, Vol. 3.

corresponds to the galvanometer deflection y , likewise given in the table, the reduced value for the *first* series

$$= 100\,000 \cdot \frac{x}{y^2},$$

for the *second* series

$$= 4000 \cdot \frac{x}{y^2}.$$

In the following table, the values of the *first* series reduced by this method are assembled:

Distance	Easterly	Westerly	Southerly	Northerly
300	189.24	190.62	77.06	77.16
400	77.61	77.28	34.77	34.78
500	39.37	39.16	18.30	18.17
600	22.53	22.38	-	-

The reduced values of the *second* series are as follows:

Distance	Easterly or Westerly
0	889.29
300	7.35.

From this latter it results that the electrodynamic force of the fixed coil on the bifilar coil, when the midpoints coincide, was

$$\frac{88929}{735} = 120.9$$

times greater, than when the midpoints were 300 mm distant from one another in the west-east direction.

In the table for the first series, we see that the corresponding values very closely agree, in east and west as well as in south and north, which is a proof for the precision of the measurement, as well as for the symmetrical placement of the fixed coil on both sides of the bifilar coil. If we now take the mean of these already closely agreeing values, and introduce for 0 distance, in conformity with the results just taken from the *second* series, the 120-fold value for the effect for 300-mm distance perpendicular to the magnetic meridian, we obtain the following table:

Distance	Perpendicular to Magnetic Meridian	In the direction of Magnetic Meridian
0	22960	22960
300	189.93	77.11
400	77.45	34.77
500	39.27	18.24
600	22.46	-

7.

Before we use this system of measurements of the reciprocal action of two conducting wires in order to directly test Ampère's law, we wish to make an interesting, if only indirect and partial, prefatory test. Namely, it is known, that one of the most important consequences of Ampère's law

for the reciprocal action of two current elements, is, that the reciprocal action of two magnets, given all the differences in their respective positions, would also be elicited by means of constant galvanic currents, which occur in a specific way on the surface or in the interior of the magnets, and, conversely, that the reciprocal actions of two galvanic coils, like those with which our measurements were carried out, given all the differences in their respective positions, would also be elicited by two constant magnets, contained in areas surrounded by the wire windings of those coils, if the free magnetism were distributed in a specific way in the interior or on the surface. Accordingly, all the results which Gauss has proven for such magnets in the *Intensitas vis magneticae...*, can be carried over to our two coils, and this can happen all the more easily, because we have ordered our measurements of the reciprocal actions of the two coils precisely as Gauss determined the measurements of the reciprocal actions of the two magnets. Gauss, *ibid.*, gave the distance of the two magnets in meters, and instead we use millimeters; further, Gauss determined the *simple* deflections, calculated with the natural state of rest of the needle as the starting-point, in degrees, minutes, and seconds, while we have stated the *doubled* tangents of the simple angle of deflection in scale units (that is, multiplied by the constant coefficient 6612.6). If, therefore, we wish to bring our measurements of the reciprocal action of the two conductor coils into the same form as those magnetic measurements, we obtain the following table of *measured* deflections:

R	v	v'
0.3 m	0° 49' 22"	0° 20' 3"
0.4 m	0° 20' 8"	0° 9' 2"
0.5 m	0° 10' 12"	0° 9' 2"
0.6 m	0° 5' 50"	-

The tangents of v and v' should then, here as there, be developed according to the descending odd powers of R , and specifically,

$$\tan v = aR^{-3} + bR^{-5}$$

$$\tan v' = \frac{1}{2}aR^{-3} + cR^{-5}$$

where a , b , c are to be experimentally determined. If, now, in our case

$$\tan v = 0.0003572R^{-3} + 0.000002755R^{-5}$$

$$\tan v' = 0.0001786R^{-3} - 0.000001886R^{-5}$$

so the following table of *calculated* deflections is yielded, to which the differences from the *measured* deflections is adjoined:

R	v	Difference	v'	Difference
0.3 m	0° 49' 22"	0	0° 20' 4"	- 1
0.4 m	0° 20' 7"	+ 1	0° 8' 58"	+ 4
0.5 m	0° 10' 8"	+ 4	0° 4' 42"	+ 2
0.6 m	0° 5' 49"	+ 1	-	

A better agreement between observed and calculated values can not be hoped for, and accordingly, Ampère's law finds itself experimentally confirmed in one of its most general and most important consequences.

The Ampère formula for the reciprocal action of two current elements, which is to be tested with respect to the present system of measuring this reciprocal action, itself consists essentially of the following: The reciprocal action of two current elements is the inverse of the square of their distance from one another, and directly proportional to the current intensity and the length of each current element, and moreover to a factor, which depends on the angle which the directions of the two current elements form with each other, and on the two angles, which the two current elements form with their straight connecting-line. Let r be the distance of the two current elements from each other, i and i' the two current intensities, ds and ds' the lengths of the two current elements, ε the angle which the directions of the two current elements form with one another, and finally ϑ the angle of the one current element with the line r , and ϑ' the angle of the other current element with the extended line r , then

$$-\frac{ii'}{rr} \left(\cos \varepsilon - \frac{3}{2} \cos \vartheta \cos \vartheta' \right) ds ds'$$

is an expression for the *magnitude* of the reciprocal action of both elements; the *direction* of both current elements coincides with their connecting-line, and for the two opposed current elements it is repulsive, when the above expression has a positive value, in the opposite case attractive.

From this law it is now possible first of all to find the expression for the combined effect which a number of current elements, which together form a *closed* line, exert on any other current element.

This effect can be separated according to three rectilinear coordinate axes. If these three components are denoted X , Y , Z , and the angles are denoted λ , μ , ν , which the current element ds' which is acted upon forms with the three coordinate axes, and the center of the element ds' is the point of origin of the coordinates, Ampère has already proven that

$$\begin{aligned} X &= -\frac{1}{2} ii' ds' \left(\cos \mu \int \frac{xdy - ydx}{r^3} - \cos \nu \int \frac{zdx - xdz}{r^3} \right) \\ Y &= -\frac{1}{2} ii' ds' \left(\cos \nu \int \frac{ydz - zdy}{r^3} - \cos \lambda \int \frac{xdy - ydx}{r^3} \right) \\ Z &= -\frac{1}{2} ii' ds' \left(\cos \lambda \int \frac{zdx - xdz}{r^3} - \cos \mu \int \frac{ydz - zdy}{r^3} \right) \end{aligned}$$

(see Mémoires de l'acad. roy. des sc. de l'Institut de France, 1823, page 214). If now, the closed line is a circular line of radius m , and the x -axis is parallel to the projection onto the plane of the circle of the straight line connecting the midpoint of the circle with the point of origin of the coordinates, and the y -axis [parallel] to the diameter of the circle perpendicular to that projection; further, p denotes the distance projected onto the plane of the circle, of the center of the circle from the point of origin of the coordinates, and ω denotes the angle which the line p forms with the radius of a circle element ds ; finally, q denotes the perpendicular from the point of origin of the coordinates to the plane of the circle, so that in this case, for the foregoing values of X , Y , Z ,

$$z = q, \quad y = m \sin \omega, \quad x = p - m \cos \omega,$$

therefore, since $r^2 = x^2 + y^2 + z^2$,

$$\begin{aligned} \int \frac{xdy - ydx}{r^3} &= mp \int \frac{\cos \omega d\omega}{r^3} - m^2 \int \frac{d\omega}{r^3} \\ &= mp \left(\frac{\sin \omega}{r^3} + 3 \int \sin \omega \cdot \frac{dr}{r^4} \right) - m^2 \int \frac{d\omega}{r^3} \\ \int \frac{zdx - xdz}{r^3} &= mq \int \frac{\sin \omega d\omega}{r^3} \end{aligned}$$

$$\int \frac{ydz - zdy}{r^3} = -mq \int \frac{\cos \omega d\omega}{r^3} = -mq \left(\frac{\sin \omega}{r^3} + 3 \int \sin \omega \cdot \frac{dr}{r^4} \right).$$

If, finally, we substitute for dr the value yielded by the equation for r , namely:

$$r^2 = x^2 + y^2 + z^2 = m^2 + p^2 + q^2 - 2mp \cos \omega,$$

that value being

$$dr = \frac{mp \sin \omega d\omega}{r},$$

and extend the integral value to the entire perimeter of the circle, then we obtain

$$\int \frac{xdy - ydx}{r^3} = 3m^2 p^2 \int \frac{\sin^2 \omega d\omega}{r^5} - m^2 \int \frac{d\omega}{r^3}$$

$$\int \frac{zdx - xdz}{r^3} = 0$$

$$\int \frac{ydz - zdy}{r^3} = -3m^2 pq \int \frac{\sin^2 \omega d\omega}{r^5};$$

consequently

$$X = -\frac{1}{2} ii' ds' \cdot m^2 \cos \mu \left(3p^2 \int \frac{\sin^2 \omega d\omega}{r^5} - \int \frac{d\omega}{r^3} \right)$$

$$Y = +\frac{1}{2} ii' ds' \cdot m^2 \left(3pq \cos \nu \int \frac{\sin^2 \omega d\omega}{r^5} + 3p^2 \cos \lambda \int \frac{\sin^2 \omega d\omega}{r^5} - \cos \lambda \int \frac{d\omega}{r^3} \right).$$

If the element ds' is part of a circle, whose radius is n , and whose plane is parallel to the coordinate axis z , and a denotes the perpendicular from the center of the circle m to the plane of circle n , c denotes the perpendicular from the center of circle n to the plane of circle m , b the distance between the two perpendiculars, and, as was the case in the previous experiment,

$$b = 0,$$

so we obtain the following equations for the angle α , β , γ , which the perpendicular to the plane of circle n forms with the coordinate axes:

$$\gamma = 90^\circ$$

$$\cos^2 \alpha + \cos^2 \beta = 1$$

$$\cos \alpha \cos \lambda + \cos \beta \cos \mu = 0.$$

Since, moreover, it is posited that

$$\cos^2 \lambda + \cos^2 \mu + \cos^2 \nu = 1$$

we obtain

$$\cos \alpha = \frac{\cos \mu}{\sin \nu}, \quad \cos \beta = -\frac{\cos \lambda}{\sin \nu}.$$

For p and q we further obtain the following equations:

$$p \cos \beta = n \cos \nu$$

$$p^2 = a^2 + n^2 \cos^2 \nu$$

$$q = c + n \sin \nu.$$

If we now multiply the components X , Y , Z respectively with the cosine of angle α , β , γ which the perpendicular makes on the plane of the circle with the coordinate axes, then the sum of these products yields the components in the direction perpendicular to the plane of the circle, namely:

$$= X \cos \alpha + Y \cos \beta + Z \cos \gamma,$$

or, if one substitutes the derived values for X , Y , $\cos \alpha$, $\cos \beta$, and γ , and eliminates p and q ,

$$= -\frac{1}{2}ii'm^2 ds' \left[3(a^2 \sin \nu - cn \cos^2 \nu) \int \frac{\sin^2 \omega d\omega}{r^5} - \sin \nu \int \frac{d\omega}{r^3} \right],$$

in which

$$r^2 = a^2 + c^2 + m^2 + n^2 + 2cn \sin \nu - 2m \cos \omega \cdot \sqrt{(a^2 + n^2 \cos^2 \nu)}.$$

If one writes in the foregoing expression for the length of the circle elements ds' its value expressed in terms of arc value and radius $= nd\nu$, and then multiply by the distance of the elements of the vertical diameter of the circle $= n \sin \nu$, one obtains the rotational moment of the force, in relation to the vertical diameter of the circle as rotational axis,

$$= -\frac{1}{2}ii'm^2 n^2 \sin \nu \cdot d\nu \left[3(a^2 \sin \nu - cn \cos^2 \nu) \int \frac{\sin^2 \omega d\omega}{r^5} - \sin \nu \int \frac{d\omega}{r^3} \right].$$

If this expression is now integrated between the limits $\nu = 0$ to $\nu = 2\pi$, then one obtains the rotational moment which the circular current m exerts on circular current n .

For the given placement of the two circles with respect to each other (namely, where their planes are perpendicular to one another, and the perpendiculars to their centers intersect one another), three principal cases can be differentiated, which occur solely in the foregoing experiments, namely, either

1. the plane of circle m halves the plane of circle n , or $c = 0$; or
2. the plane of circle n halves the circle m , or $a = 0$; or, lastly,
3. both elements mutually halve each other, or $a = 0$ and $c = 0$.

For the *first* case, there results the following expression for the rotational moment acting on circle n , namely:

$$-\frac{1}{2}ii'm^2 n^2 \int_0^{2\pi} \sin^2 \nu d\nu \left(3a^2 \int \frac{\sin^2 \omega d\omega}{r^5} - \int \frac{d\omega}{r^3} \right);$$

in which

$$r^2 = a^2 + m^2 + n^2 - 2m \cos \omega \cdot \sqrt{(a^2 + n^2 \cos^2 \nu)}.$$

For the *second* case, the following rotational moment results:

$$+\frac{1}{2}ii'm^2 n^2 \int_0^{2\pi} \sin \nu d\nu \left(3cn \cos^2 \nu \int \frac{\sin^2 \omega d\omega}{r^5} + \sin \nu \int \frac{d\omega}{r^3} \right),$$

in which

$$r^2 = c^2 + m^2 + n^2 + 2cn \sin \nu - 2mn \cos \nu \cos \omega.$$

For the *third* case the following rotational moment results:

$$+\frac{1}{2}ii'm^2 n^2 \int_0^{2\pi} \sin^2 \nu d\nu \int \frac{d\omega}{r^3},$$

in which

$$r^2 = m^2 + n^2 - 2mn \cos \nu \cos \omega.$$

The first integration of the foregoing expressions, namely, with respect to ω , can only be carried out by developing $1/r^3$ and $1/r^5$ in series of rising powers of $\cos \omega$. Since r^2 has the form:

$$l^2(1 - k \cos \omega),$$

the result is:

$$\frac{1}{r^3} = \frac{1}{l^3} \left(1 + \frac{3}{2}k \cos \omega + \frac{15}{8}k^2 \cos^2 \omega + \frac{35}{16}k^3 \cos^3 \omega + \frac{315}{128}k^4 \cos^4 \omega + \dots \right)$$

$$\frac{1}{r^5} = \frac{1}{l^5} \left(1 + \frac{5}{2} k \cos \omega + \frac{35}{8} k^2 \cos^2 \omega + \frac{105}{16} k^2 \cos^2 \omega + \frac{1155}{128} k^4 \cos^4 \omega + \dots \right).$$

Since, further

$$\begin{aligned} \pi &= \frac{1}{2} \int_0^{2\pi} d\omega = \int_0^{2\pi} \sin^2 \omega d\omega = \int_0^{2\pi} \cos^2 \omega d\omega = 4 \int_0^{2\pi} \sin^2 \omega \cos^2 \omega d\omega \\ &= \frac{4}{3} \int_0^{2\pi} \cos^4 \omega d\omega = 8 \int_0^{2\pi} \sin^2 \omega \cos^4 \omega d\omega = \text{etc.} \\ 0 &= \int_0^{2\pi} \cos \omega d\omega = \int_0^{2\pi} \sin^2 \omega \cos \omega d\omega = \int_0^{2\pi} \cos^3 \omega d\omega = \int_0^{2\pi} \sin^2 \omega \cos^3 \omega d\omega = \text{etc.}, \end{aligned}$$

we obtain

$$\begin{aligned} \int_0^{2\pi} \frac{\sin^2 \omega d\omega}{r^5} &= \frac{\pi}{l^5} \left(1 + \frac{35}{32} k^2 + \frac{1155}{1024} k^4 + \dots \right) \\ \int_0^{2\pi} \frac{d\omega}{r^3} &= \frac{2\pi}{l^3} \left(1 + \frac{15}{16} k^2 + \frac{945}{1024} k^4 + \dots \right). \end{aligned}$$

If we substitute these values, we obtain for the *first* principal case, where $c = 0$, the value of the electrodynamic rotational moment

$$= -\frac{\pi}{2} \frac{m^2 n^2}{l^3} ii' \cdot \Sigma,$$

where Σ denotes the following integral value:

$$\int_0^{2\pi} \sin^2 \nu d\nu \left[3 \frac{a^2}{l^2} \left(1 + \frac{35}{32} k^2 + \frac{1155}{1024} k^4 + \dots \right) - 2 \left(1 + \frac{15}{16} k^2 + \frac{945}{1024} k^4 + \dots \right) \right].$$

Therein,

$$a^2 + m^2 + n^2 = l^2 \text{ and } 4(a^2 + n^2 \cos^2 \nu) \cdot \frac{m^2}{l^4} = k^2.$$

If we substitute this value of k^2 , and integrate the expression ordered according to the powers of $\cos^2 \nu$, then we obtain the electrodynamic rotational moment

$$= -\frac{\pi^2}{2} \frac{m^2 n^2}{l^3} ii' \left[3 \frac{a^2}{l^2} - 2 + \frac{15}{32} \left(7 \frac{a^2}{l^2} - 4 \right) \left(4 + \frac{n^2}{a^2} \right) \frac{a^2 m^2}{l^4} + \dots \right].$$

Thus this expression yields for the first principal case under consideration the measure of the rotational moment, which a ring of radius = m exerts on a ring of radius = n . For a system of rings, whose radii progress arithmetically from 0 to m , one obtains as measure of the rotational moment, which the system exerts on the ring of radius = n , the integral of the above expression multiplied by dm , taken between the limits $m = 0$ to $m = m$. If, for the sake of brevity, we set

$$\frac{m^2}{a^2 + n^2} = v^2; \quad \frac{n^2}{a^2 + n^2} = w^2; \quad \frac{4a^2 + n^2}{16(a^2 + n^2)} = f; \quad \frac{8a^4 + 4a^2 n^2 + n^4}{64(a^2 + n^2)^2} = g,$$

then the sought-for electrodynamic rotational moment

$$= -\frac{\pi^2}{2} v^3 n^2 ii' \cdot S,$$

where S denotes the following series:

$$\begin{aligned}
S = & + \left[\frac{1}{3} - w^2 \right] \\
& - \frac{3}{2} \left[\frac{3}{5} - w^2 - (3 - 7w^2)f \right] v^2 \\
& + \frac{15}{8} \left[\frac{5}{7} - w^2 - 2(5 - 9w^2)f + 3(5 - 11w^2)g \right] v^4 \\
& - \frac{35}{16} \left[\frac{7}{9} - w^2 - 3(7 - 11w^2)f + 11(7 - 13w^2)g \right] v^6 \\
& + \frac{315}{128} \left[\frac{9}{11} - w^2 - 4(9 - 13w^2)f + 26(9 - 15w^2)g \right] v^8 \\
& - \text{etc.}
\end{aligned}$$

A precise comparison with the observational results requires a determination of the rotational moment which a system of such ring-systems with a common axis would exert on another similar system, for which still further integrations would be necessary. Meanwhile, it is easily seen that, if one proceeds from the most central of these ring systems located on an axis, its effect must be taken as the median value for each two symmetrical systems lying on both sides of it, because the effect of one of the two latter nearly exceeds by just as much that median value, as the effect of the other remains below it. This is all the more true, the smaller the fractions which the radii m and n are of the distance a of the midpoints of both systems. Hence we can hold to the last given expression as the measure of the effect.

If we now insert the values known from observation of m and n , specifically, in millimeters:

$$m = 44.4$$

$$n = 55.8,$$

and the successively following different values for a :

$$1. a' = 300$$

$$2. a'' = 400$$

$$3. a''' = 500,$$

then one obtains the following values of the rotational moment, to be multiplied by $\pi^2 i^2$:

$$1. - 1.454 4$$

$$2. - 0.654 7$$

$$3. - 0.345 2.$$

If a similar procedure is applied to the *second* principal case, where $a = 0$, then one obtains the value of the electrodynamic rotational moment

$$= +\pi^2 v^3 n^2 i i' S,$$

in which, for brevity's sake,

$$\frac{m^2}{c^2 + n^2} = v^2; \quad \frac{c^2}{c^2 + n^2} = f; \quad \frac{n^2}{c^2 + n^2} = 4gv^2$$

is formulated, and S denotes the following series:

$$\begin{aligned}
S = & + \left[\frac{1}{3} \right] \\
& - \frac{3}{2} \left[\frac{1}{5} - \frac{10}{3} fg \right] v^2 \\
& + \frac{15}{8} \left[\frac{1}{7} + \frac{2}{5} (1-14f)g + 42f^2g^2 \right] v^4 \\
& - \frac{35}{16} \left[\frac{1}{9} + \frac{3}{7} (2-18f)g - \frac{54}{5} (1-11f)fg^2 - 572f^3g^3 \right] v^6 \\
& + \frac{315}{128} \left[\frac{1}{11} + \frac{4}{9} (3-22f)g + \frac{12}{7} (1-22f+143f^2)g^2 + \frac{1144}{5} (1-10f)f^2g^3 + \frac{24310}{3} f^4g^4 \right] v^8 \\
& - \text{etc.}
\end{aligned}$$

If one now inserts in this expression the values known from observation of m and n , specifically in millimeters:

$$m = 44.4$$

$$n = 55.8,$$

and the successively following different values for c :

$$1. c' = 300$$

$$2. c'' = 400$$

$$3. c''' = 500$$

$$4. c'''' = 600,$$

then one obtains the following values of the rotational moment, to be multiplied by $\pi^2 i^2$:

$$1. + 3.562 5$$

$$2. + 1.466 1$$

$$3. + 0.742 0$$

$$4. + 0.426 7.$$

For the *third* principal case, finally, where $a = c = 0$ and m/n is a proper fraction, it does not suffice for our purpose to assume for n a median value, but rather one must multiply any value found for n by dn , and take the integral of this product between the limit values of n given by observation, which we choose to denote by n' and n'' . The resulting expression is then to be divided by $n''-n'$, in order to reduce its value to the measure of the expressions given for the first and second cases, which have not been integrated with respect to n . One then obtains for this third case, where $a = 0$ and $c = 0$, the following expression for the rotational moment:

$$\begin{aligned}
& + \frac{\pi^2 m^3}{n''-n'} ii' \left[\frac{1}{3} \ln \frac{n''}{n'} + \frac{9}{160} \left(\frac{1}{n'^2} - \frac{1}{n''^2} \right) m^2 - \frac{225}{14336} \left(\frac{1}{n'^4} - \frac{1}{n''^4} \right) m^4 \right. \\
& \left. + \frac{6125}{884736} \left(\frac{1}{n'^6} - \frac{1}{n''^6} \right) m^6 + \frac{694575}{184549376} \left(\frac{1}{n'^8} - \frac{1}{n''^8} \right) m^8 + \dots \right]
\end{aligned}$$

If one inserts in this expression the values of m , n' , and n'' known from observation, specifically in millimeters:

$$m = 44.4$$

$$n' = 50.25$$

$$n'' = 61.35,$$

one then obtains the following value of the rotational moment, to be multiplied by $\pi^2 i^2$:

$$442.714.$$

Given the proximity of the coils in this case, heed must be taken, finally, that the combined windings of each coil do not lie in one plane. Hence, if for the midpoint of the central cross-section of both coils, the distances are also $a = 0$ and $c = 0$, this does not hold true for the remaining cross-sections. From this results, as one easily sees, a diminution of the effect. In what relation this diminution stands to the total effect, can be determined with sufficient rigor, if, in the general formula given on page 38,⁹ after substitution of the values of $1/r^3$ and $1/r^5$, one simply keeps to the first term, independent of χ , and integrates its integral, taken between the limiting values $\omega = 0$ to $\omega = 2\pi$, after it is multiplied by $n \sin \nu$ and with $dmdndadc$, and $nd\nu$ is substituted for ds' , between the limits $\nu = 0$ to $\nu = 2\pi$, $m = 0$ to $m = 44.4$, $n = 50.25$ to $n = 61.35$, $a = 0$ to $a = 15$ and $c = 0$ to $c = 15$. If this calculation is carried out, an expression of the following form is obtained

$$A \left(1 - \frac{a^2}{5000} + \frac{\gamma^2}{22000} \right) \cdot \alpha \gamma,$$

in which A is simply dependent on i and i' and depends on the limiting values of m and n , and α and γ denote the greatest values for a and c . The sought-for reduction, expressed in components of the total effect, is accordingly

$$= \frac{1}{5000} \alpha^2 - \frac{1}{22000} \cdot \gamma^2,$$

and amounts to, according to the given numerical values, $\alpha = \gamma = 15$,

$$\frac{1}{29}.$$

Thus if $\frac{1}{29} \cdot 442.714$ is subtracted from the foregoing values, one obtains the following value, to be multiplied by $\pi^2 i^2$, for the electromagnetic rotational moment, corresponding to the *third case*,
 $= 427.45$.

If, by analogy with the observations, one compiles the results of the calculations, one obtains the following table for the calculated values of the electrodynamic rotational moment:

Distance	Perpendicular to the magnetic meridian	In the direction of the magnetic meridian
0	+ 427.45	+ 427.45
300	+ 3.5625	- 1.4544
400	+ 1.4661	- 0.6547
500	+ 0.7420	- 0.3452
600	+ 0.4267	-

These values, if Ampère's law is correct, must be proportional to the observed values. In fact, if all the values are multiplied by the constant factor

$$53.06,$$

then one obtains values very closely approaching the observed ones, which are contained together with the differences from the latter in the following table.

Distance	Perpendicular to the magnetic meridian	Difference	In the direction of the magnetic meridian	Difference

⁹ [N. E.] Page 72 of Weber's *Werke*, Vol. 3.

0	+ 22 680	+ 280	+ 22 680	+ 280
300	+ 189.03	+ 0.90	- 77.17	- 0.06
400	+ 77.79	- 0.34	- 34.74	+ 0.03
500	+ 39.37	- 0.10	- 18.31	- 0.07
600	+ 22.64	- 0.18	-	-

Here the first calculated value, namely, +22,680, is compared with the 120.9-fold values of those which were obtained at distances of 300 millimeters east or west, because this value, in accordance with the results drawn from the second series of experiments in Section 6, corresponds to the effect of the fixed coil, when its midpoint coincides with that of the bifilar coil. The indicated difference of 280 units appears exaggerated, and corresponds to an observational error of 1/3 scale units, which was made in the second series of experiments (Section 5) in the determination of the dynamometer deflection at a 30-mm distance.

This complete agreement between the values calculated according to Ampère's formula and the observed values (namely, the differences never exceed the possible amount contributed by unavoidable observational error) is, under such diverse conditions, a full proof of the truth of Ampère's law.

From the foregoing table, one sees that the calculated values of the electrodynamic rotational moment result partly as positive, partly as negative. The significance of the difference in signs is as follows. The planes of the two wire coils were presumed to be at right angles to one another. The electrodynamic rotational moment, which the fixed coil exerts on the moveable one (the bifilar coil), endeavors to make the plane of the latter parallel to the plane of the former, which can occur in a double fashion, starting from the original right-angled position, namely, by means of rotation toward both sides. The one rotation leads to the kind of parallelism of the planes, in which the currents go around an axis perpendicular to both planes in the same way; the other rotation, in contrast, leads to the kind of parallelism in which the currents go around such an axis in opposite ways. The electrodynamic rotational moment, according to whether it effects the former or the latter rotation, will be designated in the calculation as positive or negative. The signs of the calculated values in the foregoing table thus teach us, that if the fixed coil acts on the bifilar coil at a distance from north or south, a rotation of the bifilar coil results, which, if it amounts to 90 degrees, will cause the currents to go in *opposite* directions around axes aligned in the same way. The latter then takes place, according to calculation, if the midpoints of both coils coincide.

These results of calculation also find themselves fully confirmed by the results of all observations. The conditions to be therefore taken into consideration are not extensively discussed in the description given above, simply because to completely state the direction of the current in all particular parts of the conducting circuit and the direction of the observed rotations would have expended too much space. Moreover, since no exact measurements are necessary for testing these results of calculation, it was also possible to achieve their confirmation, by the methods used up to now, and that confirmation has already been thereby obtained, for which reason it suffices here, to take note merely in a general way of the agreement of the observations communicated with the foregoing results of calculation.

9.

Ampère's law gives the calculated rotational moments expressed in *absolute measurements*, assuming that, for the values of the current intensity i , an absolute measure of intensity is taken as the basis; specifically, in so doing, the fundamental measure of current intensity is to be considered as that current intensity, with which two equal, parallel current elements perpendicular to the

connecting-line, at the same distance from the unit of length, exert a force on each other, which forms the same fraction of the unit of force established in mechanics, as the *square of the length of those current elements* does of the *unit of area*. Then we put into Ampère's formula for the magnitude of the electrodynamic force of two current elements of length α and of equal intensity, namely:

$$-\frac{\alpha^2}{r^2} i^2 \left(\cos \varepsilon - \frac{3}{2} \cos \vartheta \cos \vartheta' \right),$$

1. the angle ε , which the two current elements form with each other, $= 0^\circ$ or $= 180^\circ$; 2. the angles ϑ and ϑ' which both current elements form with the connecting line, $= 90^\circ$ or $= 270^\circ$; 3. the distance $r = 1$; and so the value of the electrodynamic force obtained for the *unit* of current intensity is

$$\pm \alpha^2,$$

i.e. in Ampère's formula, a unit of current intensity is presupposed, in which the *electrodynamic force in the designated case* is in the ratio to the *unit of force*, as

$$\alpha^2 : 1,$$

that is, as the *square of the length of those current elements* is to the area. Thus the *electrodynamic principle* itself underlies this fundamental metric of current intensity.

For the purpose of our measurements, we have, however, based the *electromagnetic principle* on the unit of current intensity, according to which the fundamental unit of current intensity is to be posited as that current intensity, which must occur in a conductor demarcating the area, in order to elicit the same effects on a *distant magnet*, as a magnet in the same place, whose magnetic moment is equal to that specified by Gauss in the *Intensitas...*, and whose axis has the same direction as the normal of the plane of the current.

These two fundamental measures may now be compared with each other according to the relationship given by Ampère between *electrodynamics* and *electromagnetism*. For, according to this relationship, the other *distant magnet* can also be deflected in the same way as the first, by means of a closed current.

The rotational moment of a magnet on another distant magnet, when their magnetic moments $= m$ and m' according to the absolute metric, as easily results from Gauss's formula ("Resultate aus den Beobachtungen des magnetischen Vereins im Jahre 1840," pp. 26-34¹⁰),

$$= \frac{mm'}{r^3} \sin \delta \cdot \sqrt{1 + 3 \cos^2 \psi}$$

will be found, where ψ designates the angle which the axis of the first magnet makes with the connecting line r , and δ the angle, which the axis of the second magnet defines with that alignment, for which the rotational moment is $= 0$.

If a current of intensity χ is now applied at the location of the first magnet, which bounds the small plane λ , whose normal has the same alignment as the magnet's axis, then according to the electromagnetic law (which gives the strength of the electromagnetic force of a current element of length α and intensity χ on an element of magnetic fluid μ at distance r , when r and α enclose the angle φ , as $= \alpha \chi \mu \sin \varphi / r^2$, specifically normal to the plane which is parallel to α and r) the rotational moment exerted by this current on the distant magnet

$$= \frac{\chi \lambda \cdot m'}{r^3} \sin \delta \cdot \sqrt{1 + 3 \cos^2 \psi},$$

¹⁰ [N. H. W.] Gauss' *Werke*, Vol. V, page 427 to 435.

in which for the current intensity χ , the *electromagnetic measure* given above is the basis. Thus, according to this metric, it must be the case that

$$\chi\lambda = m$$

if this rotational moment is to equal the preceding one.

According to the relationship given by Ampère, without changing the effect, in the same way *the second magnet can be replaced by a closed circuit*, for which

$$\chi'\lambda' = m',$$

and this yields the magnitude of the rotational moments, which the first current exerts on the second,

$$= \frac{\chi\chi'\lambda\lambda'}{r^3} \sin \delta \cdot \sqrt{1 + 3\cos^2 \psi},$$

in which the *electromagnetic measure* given above is the basis for the current intensities χ and χ' .

If, however, we now calculate according to Ampère's formula (page 36)¹¹ the rotational moment, which such a small plane-current exerts on another at a great distance, the result is¹²

¹¹ [N. E.] Page 70 of Weber's *Werke*, Vol. 3.

¹² [N. A.] The case in which $\delta = \psi = 90^\circ$, and consequently the electrodynamic rotational moment

$$= -\frac{1}{2} \frac{ii'\lambda\lambda'}{r^3},$$

corresponds to the *first major case* considered above, for which the strength of the rotational moment on page 39 [[N. E.] page 74 of Weber's *Werke*, Vol. 3.] was found

$$= -\frac{\pi^2}{2} \frac{m^2 n^2}{l^3} ii' \left[3 \frac{a^2}{l^2} - 2 + \frac{15}{32} \left(7 \frac{a^2}{l^2} - 4 \right) \left(4 + \frac{n^2}{a^2} \right) \frac{a^2 m^2}{l^4} + \dots \right]$$

For large distances, as assumed here, m and n become negligible vis-à-vis l , and r can be substituted for a and l ; thus for this case, the rotational moment will

$$= -\frac{\pi^2}{2} \frac{m^2 n^2}{r^3} ii',$$

which is identical with the values derived for this case from the formula above, because πm^2 and πn^2 designate the areas λ and λ' .

The above-cited *analogous* laws of magnetism, electromagnetism, and electrodynamics, from which the simple association of these different classes of phenomena can easily be perceived, which does not immediately appear from the *fundamental laws*, can be derived from the latter in the following way.

1. Derivation of the law of magnetic effect, which one magnetic rod exerts on another at a distance.

Gauss, in the "Resultaten, etc. 1840" [[N. H. W.] Gauss, *Werke*, Vol. V, page 427], derived from the *fundamental law of magnetism*, the law of magnetic effect, which one magnetic rod exerts on the unit of north-magnetic fluid, conceived of as concentrated in a distant point. This law is the following: If (Figure 12) A is the midpoint of the magnetic rod, whose magnetic moment is designated as m , n an arbitrary other point on the north pole side of its magnetic axis, which goes through A , C the point, for which the magnetic effect of the magnetic rod on the unit of north magnetic fluid conceived of as concentrated in that very place, is to be determined, and if CB is a normal with respect to CA in the plane in which n , A , C lie, and B its point of intersection with the magnetic axis, and if, finally, D cuts from AB the segment $AD = AB/3$: then the *strength* of the force, which the magnetic rod exerts on the unit of north magnetic fluid, conceived of as concentrated at point C ,

$$= \frac{CD}{AD} \cdot \frac{m}{AC^3}.$$

The *direction* of this force is, if nAC is an obtuse angle, CD , and, if nAC is an acute angle, DC .

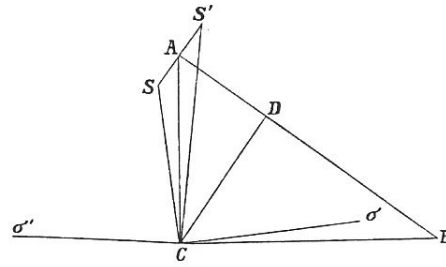

Fig. 12.

Now, in triangle ABC , because $ACB = 90^\circ$,

$$AC = AB \cos BAC = 3AD \cos DAC .$$

Further, in triangle ACD ,

$$CD = \sqrt{AC^2 + AD^2 - 2AC \cdot AD \cdot \cos DAC} = AD \cdot \sqrt{1 + 3 \cos^2 DAC} ,$$

and therefore,

$$\frac{CD}{AD} = \sqrt{1 + 3 \cos^2 DAC} .$$

If we make $AC = r$ and $nAC = \psi$, then, because $DAC^2 = \cos^2 nAC = \cos^2 \psi$, the *strength* of the force

$$\frac{CD}{AD} \cdot \frac{m}{AC^3} = \frac{m}{r^3} \cdot \sqrt{1 + 3 \cos^2 \psi} .$$

If, in a steel rod, the north magnetic Masse $+\mu$ and the south magnetic Masse $-\mu$ are divided at C by line α , which is infinitely small with respect to r , then $\alpha\mu = m'$ is the magnetic moment of the steel rod and $+\frac{m\mu}{r^3} \sqrt{1 + 3 \cos^2 \psi}$ and

$-\frac{m\mu}{r^3} \sqrt{1 + 3 \cos^2 \psi}$ are the two forces, which act on it in the direction CD or DC . If n' is the end-point of the small line α , in which the Masse $+\mu$ is thought of as concentrated, and C its midpoint, and δ designates the angle which Cn' forms with the direction CD or DC of the force defined above, then $\alpha \sin \delta$ is the distance of the points of action of both forces, estimated perpendicular to their direction. The product of this distance into the value of the force above, then yields the rotational moment, which the magnetic rod at A exerts on the magnetic rod at C ,

$$= \alpha \sin \delta \cdot \frac{m\mu}{r^3} \sqrt{1 + 3 \cos^2 \psi} = \frac{mm'}{r^3} \sin \delta \sqrt{1 + 3 \cos^2 \psi} .$$

The magnet at C is thereby rotated in the plane ACD in the way in which Cn approaches the direction CD or DC of the force defined above.

2. Derivation of the law of electromagnetic effect, which a closed plane current exerts on a magnetic rod.

From the *electromagnetic law*, the effect of a closed current on the north magnetic measure $+\mu$ of the magnetic rod, which is thought of as concentrated in a point at C (Figure 12), can first of all be determined. One puts through C and through the midpoint A of the plane delimited by the current, a plane ACB perpendicular to the latter, CB being perpendicular to CA ; s and s' are the intersection-points of the current with this plane. Further, each current element is separated into three elements perpendicular to each other, the first directed to C , and the second perpendicular to the direction CB . The elements directed toward C have no effect on the magnetism at C , and thus can remain entirely out of consideration, because, in the general expression for the force strength, $= \alpha\chi\mu \sin \varphi / r^2$, the value for them of φ is $= 0$. To the second class belong the two perpendicular elements in s and s' on the plane ACB , whose length is designated as ds . The force which the former exerts on the magnetism at C has, according to the electromagnetic law, the direction $C\sigma$ perpendicular to Cs ; the force of the latter has the direction $C\sigma'$ perpendicular to Cs' , and the strength of this force is, if χ designates the current intensity according to the basic electromagnetic measure,

$$\frac{\chi\mu ds}{Cs^2} \text{ and } \frac{\chi\mu ds}{Cs'^2} .$$

If one now separates these forces parallel to CA and perpendicular to it, then we obtain

the components parallel with $CA = \frac{\chi\mu ds}{Cs^2} \cos AC\sigma + \frac{\chi\mu ds}{Cs'^2} \cos AC\sigma'$

the components perpendicular to $CA = \frac{\chi\mu ds}{Cs^2} \sin AC\sigma - \frac{\chi\mu ds}{Cs'^2} \sin AC\sigma'$.

If we now use ψ to designate the angle which the normal of the current plane AB forms with $AC = r$, and take note that As and As' will become negligible with respect to r , then we obtain

$$Cs = r - As \cos \psi, \quad Cs' = r + As' \cos \psi$$

$$\text{or } \frac{1}{Cs} = \frac{1}{r} \left(1 + \frac{As}{r} \cos \psi \right), \quad \frac{1}{Cs'} = \frac{1}{r} \left(1 - \frac{As'}{r} \cos \psi \right);$$

$$\cos AC\sigma = \sin ACs = ACs$$

$$sCs' = \frac{(ss')}{r} \cos \psi.$$

Substituting for these values, and designating the distance ss' as x , we obtain the components parallel to CA

$$= \frac{\chi\mu}{r^3} \cos \psi \cdot x ds.$$

Since all current elements surround A very closely, the factor $\frac{\chi\mu}{r^3} \cos \psi$ can be regarded as constant, and we thus obtain the components parallel to CA for all current elements of the *second* class:

$$= \frac{\chi\mu}{r^3} \cos \psi \cdot \int x ds.$$

But the integral $\int x ds$ represents the area $= \lambda$ delimited by the current; accordingly the components parallel to CA for all current elements of the *second* class are given by

$$= \frac{\chi\lambda\mu}{r^3} \cos \psi.$$

Likewise, the components perpendicular to CA for all current elements of the *second* class are

$$= \frac{\chi\lambda\mu}{r^3} \sin \psi.$$

In a similar way we further find the components parallel to CA for all current elements of the *third* class

$$= \frac{\chi\lambda\mu}{r^3} \cos \psi,$$

the components perpendicular to CA for all current elements of the *third* class

$$= 0.$$

The resultant of all these forces is thus

$$= \frac{\chi\lambda\mu}{r^3} \sqrt{4 \cos^2 \psi + \sin^2 \psi} = \frac{\chi\lambda\mu}{r^3} \sqrt{1 + 3 \cos^2 \psi}.$$

The direction of these resultants falls on the plane ACB and forms with CA an angle, whose tangent is equal to the components perpendicular to AC , $= \chi\lambda\mu \sin \psi / r^3$, divided by the components parallel to AC , $= 2\chi\lambda\mu \cos \psi / r^3$, that is,

$$= \frac{1}{2} \tan \psi.$$

Since $CAB = \psi$ and $ACB = 90^\circ$, then, if $AD = AB/3$,

$$\sin ACD : \sin \psi = \frac{1}{3} AB : CD$$

$$\cos ACD : \cos \psi = \frac{2}{3} AB : CD,$$

therefore

$$\tan ACD = \frac{1}{2} \tan \psi,$$

whose result is that CD is the direction of the resultant. It is assumed in these derivations, that if one thinks of oneself as perpendicular to the current plane standing on A , with the head at B , the current circulates in the manner of the apparent daily motion of the sun. If the opposite is the case, then the force direction DC is to be substituted for CD .

$$= -\frac{1}{2} \frac{ii' \lambda \lambda'}{r^3} \sin \delta \cdot \sqrt{1 + 3 \cos^2 \psi} ,$$

in which the current intensities i and i' are based on the *electrodynamic measure* given above.

Now, from this it follows that, if the latter value, according to the *electrodynamic measure*, is to be identical with the former, according to the *electromagnetic measure*, the electrodynamic and electromagnetic measures of current intensity defined above must stand in relation to one another such that χ and χ' , according to the latter measure, designate the same current intensities as $i\sqrt{1/2}$ and $i'\sqrt{1/2}$ according to the former. Consequently, all determinations of current intensity made according to the fundamental *electromagnetic measure* are to be multiplied by the constant factor $\sqrt{2}$, in order to reduce them to the measure of *electrodynamic intensity* underlying the Ampère formula.

Accordingly, the closed circuit at A has the same effect on the magnetism at C , as according to [derivation] (1) a magnetic rod, whose magnetic moment is

$$m = \chi \lambda ,$$

and whose magnetic axis coincides with the normal of the current plane, specifically, the south pole runs on that side of the current plane, taking which as the point of observation, the current runs in the direction of the apparent daily motion of the sun. It follows from this, that if we place, as in (1), a magnetic rod at C , whose magnetic moment = m' , and whose magnetic axis forms the angle δ with CD , the rotational moment, which the closed circuit exerts at A on this magnetic rod, is equal to that rotational moment found in (1), if one substitutes therein $\chi \lambda$ for m , thus

$$= \frac{\chi \lambda m'}{r^3} \sin \delta \sqrt{1 + 3 \cos^2 \psi} ,$$

which was to be proven.

3. Derivation of the law of electrodynamic effect, which a closed plane current exerts upon another at a distance.

The law of the effect exerted by a closed plane-current on a current element at a distance, was already derived by Ampère on pp. 214 and 227 of his Treatise on the law of electrostatics. It can be expressed in the following way: If the current element is located at C (Figure 12) and the closed plan-current at A , AB is the normal to the current plane, CB is perpendicular to CA , and $AD = AB/3$, then the force, which the current at A exerts on the current element at C , is perpendicular to the two directions of the current element itself and of the line CD ; and if, according to the basic electrodynamic measure we designate the intensity of the closed current as i , and that of the current element as i' , and further, the length of the current element as ds' , $r = AC$, and $\psi = CAD$, the strength of the force is then

$$= \frac{1}{2} ii' ds' \frac{\lambda}{r^3} \sqrt{1 + 3 \cos^2 \psi} .$$

If, now, a closed plane current is also located at C , and the normal to its plane forms with CD the angle δ , then each element of this current can be separated into two elements, one parallel to the line in which a plane normal to CD cuts the plane of the current, the other perpendicular to this cutting-line. The first elements can be ordered pairwise in the same length ds' and connected to that cutting-line by means of a perpendicular. If the length of this perpendicular is designated as x , then the result is that the effect of the closed circuit at A on such a pair consists of a rotational moment, which is equal to the product of $x \sin \delta$ in the force cited above, that is,

$$= \frac{1}{2} ii' \frac{\lambda}{r^3} \sin \delta \sqrt{1 + 3 \cos^2 \psi} \cdot x ds' .$$

The current at A thus exerts on all current elements parallel with the cutting-line above the rotational moment

$$= \frac{1}{2} ii' \frac{\lambda}{r^3} \sin \delta \sqrt{1 + 3 \cos^2 \psi} \cdot \int x ds ,$$

where the integral $\int x ds$ designates the area = λ' demarcated by the current at C ; therefore this rotational moment is

$$= \frac{1}{2} ii' \frac{\lambda \lambda'}{r^3} \sin \delta \sqrt{1 + 3 \cos^2 \psi} .$$

If one considers in a similar way the effect of the closed circuit at A on the elements perpendicular to the foregoing cutting-line, then the rotational moment will be = 0, from which it follows, that the just-given rotational moment is the entire effect, which the closed current at A exerts on the closed current at C , which was to be proven, Q.E.D.

Assuming this, the *constant factor*, by which all calculated values are to be multiplied, in order to give the observed values, can also be derived from the galvanometer observations, and the comparison of the factors thusly determined with those utilized above, namely, with

$$53.06,$$

then finally there results a touchstone for the correctness of the *absolute* values calculated from Ampère's formula, or for the correctness of the relation posited between electrostatics and electromagnetism.

For this purpose, there is a triple requirement: 1. determining the factor with which all dynamometer effects observed by us are to be multiplied, in order to reduce them to the absolute measure of *rotational moment*; 2. determining the factor with which all galvanometer effects observed by us are to be multiplied, in order to reduce them to the *fundamental electromagnetic measure of current intensity*; 3. determining the *areas* which are demarcated by the bifilar coil and by the fixed coil of the dynamometer.

1. Determination of the factors for reduction of the observed dynamometer effects to absolute measure.

The observed dynamometer deflections are measured according to *scale units* and hence, in order to transform them into absolute *angular measurement*, given the smallness of the angle, are to be divided simply by the doubled horizontal displacement of the scale mirror (= 6,612.6 scale units). Further, the given number of scale units corresponds to the difference between the positive and negative displacement, and hence, moreover, is still to be divided by 2, in order to reduce it to the simple deflection. Thus if x designates the *number of scale units* in the foregoing tables, then

$$\frac{x}{13\,225.2}$$

yields the simple *angular displacement* in radius units. Further, if S designates the *static moment* of the bifilar coil given in Section 6, to which the deflections have been reduced, then, if x designates the reduced value, one need only multiply the angular displacement = $x/13,225.2$ with that value of S , to obtain the *electrodynamic rotational moment*, which the deflection elicited, expressed according to the fundamental measure specified by statics. Thus, this moment is

$$= \frac{x}{13\,225.2} \cdot S = 3\,634 \cdot x.$$

Consequently, 3,634 is the constant factor, with which the dynamometer deflections stated at the end of Section 6 are to be multiplied, in order to be reduced to absolute measure.

2. Determination of the factors for reduction of observed galvanometer effects to absolute measure.

The galvanometer effects are likewise stated above in *scale units*, and specifically, the given number y corresponds to the difference between the positive and negative displacement. Since the horizontal distance of the mirror from the scale amounts to 1,103 scale units on the galvanometer, the simple *angular displacement* according to absolute angular measure, i.e. in radius units, will be

$$= \frac{y}{4\,412}.$$

This angular displacement is elicited by means of a wire coil, through which the current to be determined is passing, and which was placed at a 217-millimeter distance west of the small magnetometer.

If the sine of this angular displacement is multiplied by the directional force = $m'T$, which the terrestrial magnetism = T exerts on the compass, then we obtain the rotational moment with which the terrestrial magnetism drives the deflected compass back to the magnetic meridian,

$$= m'T \cdot \sin \frac{y}{4412} \cdot \frac{180^\circ}{\pi}.$$

According to absolute measure, in this formula the value of

$$T = 1.91$$

is to be used, as it was found at the location of the compass.¹³

The compass was now kept in equilibrium in that deflected position, by means of that rotational moment, which the current in the 217-mm-distant wire coil exerted on it, and consequently the strength of this latter rotational moment was

$$= 1.91 \cdot m' \sin \frac{y}{4412} \cdot \frac{180^\circ}{\pi}.$$

According to the law demonstrated on page 46 in Section 2 of the footnote,¹⁴ if the current had acted from a *great* distance r , this latter rotational moment would be

$$= \frac{\chi \lambda m'}{r^3} \sin \delta \cdot \sqrt{1 + 3 \cos^2 \psi},$$

in which the value of ψ for our case = 0, and δ is the expansion of the observed displacement angle to 90° , by means of which this expression becomes

$$= 2 \frac{\chi \lambda m}{r^3} \cos \frac{y}{4412} \cdot \frac{180^\circ}{\pi}.$$

Now, however, the distance of 217 millimeters becomes far too small to bring this law into immediate application. Hence, in order to facilitate this application, I carried out special experiments to compare the effect of the coil at the 217-mm distance with its effect at greater distances r , for which the foregoing law is applicable, and found the ratio of these effects to be

$$1 : 1388 \cdot \frac{10^4}{r^3}.$$

The observed rotational moment = $1.91 \cdot m' \sin \frac{y}{4412} \cdot \frac{180^\circ}{\pi}$ must thus be multiplied by the factor

$$1388 \cdot \frac{10^4}{217^3}$$

if it is to be made equivalent for the expression which is valid for large distances; thus we obtain

$$1388 \cdot \frac{10^4}{217^3} \cdot 1.91 \cdot m' \sin \frac{y}{4412} \cdot \frac{180^\circ}{\pi} = 2 \frac{\chi \lambda m'}{217^3} \cdot \cos \frac{y}{4412} \cdot \frac{180^\circ}{\pi},$$

and from this results, by small arcs, the value

$$\chi \lambda = 3004 \cdot y.$$

By means of precise measurement, however, it was found that

$$\lambda = 8313440 \text{ square millimeters.}$$

From this results

$$\chi = 0.0003614 \cdot y,$$

from which it follows that

¹³ [N. A.] The compass stood near the wall of an adjoining room, in which large magnets were installed; if these magnets were removed, the value of T sank to 1.83, which is approximately the present value for the horizontal element of terrestrial magnetism in Leipzig.

¹⁴ [N. E.] Page 84 of Weber's *Werke*, Vol. 3.

0.000 361 4

is the factor for reduction of the observed galvanometer effects to the fundamental *electrodynamic* measure of current intensity. This is the factor already introduced above in Section 6 for the purpose of reducing the observations to equal directional force of the bifilar coil. The current intensity i according to the fundamental *electrodynamic* measure underlying Ampère's formula is finally obtained by means of multiplying the effects observed in scale units by the factor $0.000\,3614 \cdot \sqrt{2}$. It is to be noted, however, that this reduction factor rests on empirical data, which were in part obtained only in approximation, and therefore make claim to no great precision.

3. Determination of the area, which is demarcated by the bifilar coil and by the fixed coil of the dynamometer.

The area of the bifilar coil is already given in Section 6 as
= 29,314,000 square millimeters.

In the same way, the area of the other fixed coil of the dynamometer was also determined, namely,
= 31,327,000 square millimeters.

It is evident that, in view of the indirect method by which it was made, this determination, too, can make claim to no great precision.

With the help of these three determinations, it is finally possible to also subject to empirical proof the *absolute* value of electrodynamic effects, as yielded by Ampère's law. Namely, from (2) is obtained the value of i^2 , which corresponds to the *normal* current intensity, to which the observations are reduced. That is, if, in accordance with page 33,¹⁵ for [the intensity] we make

$$y^2 = 100\,000,$$

then

$$i^2 = 2\chi^2 = 2 \cdot 0.000\,3614^2 \cdot y^2 = 0.02612.$$

Further, one easily sees that in the calculation of electrodynamic rotational moment on page 40 made according to Ampère's formula,¹⁶ the area of the bifilar coil was taken into account only as

$$\pi \cdot 55.8^2 \text{ square millimeters}$$

instead of, according to (3)

$$= 29\,314\,000 \text{ square millimeters,}$$

and that in the same way, the area of the fixed coil of the dynamometer (in the place cited) was calculated only as

$$\frac{1}{3}\pi \cdot 44.4^3 \text{ square millimeters}$$

instead of, according to (3)

$$= 21,327,000 \text{ square millimeters.}$$

From this it follows that the *calculated values* presented in the table on page 42¹⁷ are to be multiplied by

$$\frac{29\,314\,000 \cdot 21\,327\,000}{\frac{1}{3}\pi^2 \cdot 55.8^2 \cdot 44.4^2} \cdot \pi^2 i^2 = 180\,000$$

in order to determine the electrodynamic rotational moment according to Ampère's law in absolute measure. From (1), however, one sees that the dynamometer effects *observed* in scale units in the

¹⁵ [N. E.] Page 67 of Weber's *Werke*, Vol. 3.

¹⁶ [N. E.] Page 76 of Weber's *Werke*, Vol. 3.

¹⁷ [N. E.] Page 78 of Weber's *Werke*, Vol. 3.

table on page 34¹⁸ are to be multiplied by the factor 3,634, in order to reduce them to absolute rotational moments. Thus if the previous factor is divided by this latter one, the factor 49.5 is obtained, with which the *calculated* values presented in the table on page 42¹⁹ are to be multiplied, in order to be compared with the *observed* values presented in the table on page 34.²⁰ This factor is about 6% smaller than the factor 53.06 above, which was immediately derived from the comparison of the calculated and observed values, a difference of the kind that had to be expected with so many elements taken from experimental evidence which are necessary for the determination of factors, among which several were only approximately determined (see [2] and [3]). Thus, the correctness of the *absolute* values calculated from Ampère's formula, or the correctness of the relation between electrostatics and electromagnetism, is thereby confirmed only in so far as the experiments which were made can be validated. This test of the *absolute values* or of the stated relationship between *electrostatics* and *electromagnetism* was not originally among the purposes of the experiments communicated here, which merely concerned the dependence of the electrodynamic force on the mutual position and distance of the conducting wires which acted on each other, otherwise arrangements would have been made to determine the galvanic current with greater precision also according to its *absolute* intensity, as well as to *directly* ascertain the number of windings on the part of the two coils of the dynamometer; that test, however, is presented at the same time in approximate fashion, because the experiments described placed the essential data at our disposal. Yet, because not *all* these data possess the requisite precision, a more rigorous execution of this test must be reserved for a future occasion. It is readily evident which arrangements and alterations are to be made in the experiments in order to lend greater precision to the data determined here with less exactness, and requires no further discussion.

Volta-induction with the electro-dynamometer.

10.

Up to now we have considered the first class of electrodynamic phenomena, namely, those discovered by Ampère, having to do with the forces with which the *conductors* seek to move one another at a given current intensity, and we have confirmed the law established by Ampère for this class of phenomena. Ten years later, Faraday's discovery adds to this first class of electrodynamic phenomena a second class, where the electrodynamic effects consist of forces which seek to move, not the conductors, but the *electricity in the conductors*. For these phenomena, comprehended under the name *Volta-induction*,²¹ we can distinguish two fundamental experiments, both of which originate from Faraday.

At the very beginning of his "Experimental Researches in Electricity" ("Experimental-Untersuchungen über Elektrizität," *Poggendorff's Annalen* 1832, Vol. XXV, page 93, Section 10), Faraday describes the *first* fundamental experiment in voltaic induction, where two insulated copper wires were wound close to another on a wooden roller, and one was connected with the galvanometer, the other with a voltaic battery, and where the generation of a current in the first

¹⁸ [N. E.] Page 68 of Weber's *Werke*, Vol. 3.

¹⁹ [N. E.] Page 78 of Weber's *Werke*, Vol. 3.

²⁰ [N. E.] Page 68 of Weber's *Werke*, Vol. 3.

²¹ [N. E.] The expression utilized by Weber, "Volta-induktion," had been first suggested by Faraday himself in paragraph 26 of his first paper on electromagnetic induction published in 1831, see M. Faraday, *Experimental Researches in Electricity*, in *Great Books of the Western World*, Vol. 45, §26, page 267 (Encyclopaedia Britannica, Chicago, 1952): "For the purpose of avoiding periphrasis, I propose to call this action of the current from the voltaic battery, *volta-electric induction*." In this English translation we utilized the expressions "Volta-induction" and "voltaic induction" for this class of phenomena which is nowadays called Faraday's law of induction.

wire was observed each time at the moment when the circuit involving the second wire, was either broken or closed again. The *second* fundamental experiment follows in Section 18, where he fastened two copper wires bent in the same zigzags, separated from each other, to two boards, and connected one with the galvanometer, the other with the voltaic battery, and where the generation of a current in the first wire was observed each time at the moment when the board with this wire was either suddenly brought close from far away and laid on the board with the second wire, or the board lying on the other board was suddenly lifted and taken away from that other board.

After Faraday, Nobili and Lenz in particular occupied themselves with this kind of induction, and the latter established a simple law, by means of which the induction of a current in a conductor which is moved, can be reduced to Ampère's law of electrodynamic motions.

“Immediately upon reading Faraday's Treatise,” says Lenz (*Poggendorff's Annalen* 1834, Vol. XXXI, page 484 f.), “it seemed to me as though it must be possible to very simply reduce the collective experimental results of electrodynamic distribution to the formulations for electrodynamic motions, so that if one assumes these to be established, those too are determined, and since this view confirmed itself for me through multiple experiments, I will discuss them in what follows, and test them partly with familiar experiments, partly with experiments carried out expressly for this purpose. The law, according to which the reduction of magneto-electric phenomena to electromagnetic phenomena occurs, is as follows:

“If a metallic conductor moves in the vicinity of a galvanic current or a magnet, a galvanic current will be induced in it, whose direction is such that it would have elicited motion in the wire at rest, which would be directly opposite to that given to it, assuming that the wire were movable only in the direction of the movement or opposite to it.”

For confirmation of this law, insofar as it concerns the induction of a current in a conductor which is put into motion, Lenz now introduces the following three experiments by Faraday, by himself, and by Nobili.

“a) When, of two straight-line conductors parallel to one another, one has a galvanic current running through it, and if the other conductor is brought closer to it in a parallel direction, during the movement, an opposite current will be induced in the conductor which is moved from that in the unmoved conductor; however, if it is moved away, the induced current is in the same direction as the arousing one.” (Faraday.)

“b) When, of two vertical circular conductors of approximately the same diameter, which stand with their planes perpendicular to each other, the one, standing fixed, has a galvanic current flowing through it, and if then the other, which is rotatable around the common vertical diameter as its axis, is suddenly brought out of the perpendicular into a position lying parallel, then a current is generated in it, which is opposite to the current in the other conductor. I carried out this last experiment,” says Lenz, “with two circular conductors, each consisting of 20 windings of covered copper wire; one was connected to a 2-square-foot large zinc-copper couple, the other to a sensitive Nobili multiplier.”

“c) If a bounded conductor, standing perpendicular on an unbounded conductor which has a galvanic current flowing through it, moves along this unbounded conductor and in the direction of its current, then a current is generated in it, which is directed toward the bounded conductor; however, if the bounded conductor moves against the direction of the current in the unbounded conductor, the direction of the current induced in it by means of distribution is toward the unbounded current. (Nobili, *Poggendorff's Annalen* 1833, no. 3, page 407).”

By means of the above law, first stated by Lenz, the induced currents are determined, to begin with, only according to their direction: Lenz did not give a quantitative determination for the intensity of the induced currents. This, however, was provided by Neumann in a still unpublished Treatise, of which an excerpt has just appeared in *Poggendorff's Annalen* 1846, Vol. LXVII, page 31. The quantitative determinations thereby obtained, however, require a test by experiment, for which the necessary measurements are still lacking.

Henry reported original experiments on the induction of currents in a stationary conductor by *breaking* the circuit of a nearby voltaic battery (*Poggendorff's Annalen* 1842, supplementary volume, page 282), putting the induced wire at varying distances and in varying positions. He also re-used the induced current itself, in order to induce a current in a third conductor, and so forth. After these experiments, he directed these induced currents in parallel wires alternately in opposite directions; the first, however, being the same direction as the voltaic battery's current which was lost due to the *breaking* of the circuit.

In this Section, it will now be shown, *first*, how the phenomena of voltaic induction can also be observed with the electro-dynamometer, then some *determinations of measure* for the second of Faraday's fundamental experiments will be reported.

In representing the phenomena of voltaic induction, two different things must be essentially distinguished, namely, *first*, the apparatus for inducing currents, and *second*, because the induced current is not immediately perceptible, an apparatus for observing a perceptible effect of the induced current. In the second Faraday fundamental experiment, for example, the two zigzag-shaped bent copper wires, of which one is attached to a galvanic circuit, along with the device by which both wires are suddenly brought closer to each other or farther distant from each other, constitutes the first apparatus, which is for *inducing* the current; the *galvanometer*, on the other hand, which is connected with the other wire, constitutes the second apparatus, for observing a *visible effect* of the induced current. Thus the two essential pieces of apparatus for the experiment are distinguished and separated from each other.

Now, however, an essential simplification of the experiment can be achieved by means of the *electro-dynamometer*, where it is possible to use the same apparatus which serves to induce the current, for observing a visible effect of the current as well. That is, the bifilar coil of the electro-dynamometer is made to *oscillate*, and this motion is used for induction; then the *decrease of the arc of the oscillations* of this bifilar coil is observed, which, as will be shown forthwith, is the result of the electrodynamic reciprocal action of the inducing and induced currents. The lawfulness of the induction meditative oscillations, as well as of the decrease of the arc of the oscillations, observed as the visible effect of the induced current, permits us to carry out precise *determinations of measure* for these phenomena of induction.

Namely, if one connects the wire of the *one* coil of the dynamometer, while the bifilar coil is *swinging*, with a voltaic current, then, in order to *induce* a current in the *other* coil, one need only join the two wire ends to one another. This induced current, which in itself is of course imperceptible in the second coil, now immediately exerts in the dynamometer itself a *perceptible electrodynamic force* on the current of the first coil, and thereby changes the oscillation of the bifilar coil. Thus, if one observes this change, one can come to know the electrodynamic force which causes it, and in turn, from the electrodynamic force, to know the *induced current*, to which it is proportional, without it being necessary to conduct the induced current through the multiplier of a *galvanometer*. The *dynamometer* itself thus serves for *inducing* the current as well as for observing a *visible and measurable effect* of the induced current.

If the bifilar coil is stationary, no current will be induced; consequently the electrodynamic force = 0, and the bifilar coil will then not be moved by the fixed coil. However, if the bifilar coil is swinging, there are two cases to distinguish: i.e., either the fixed coil is connected to the voltaic

battery and the bifilar coil is a closed circuit in itself; in that case a current is induced in the swinging bifilar coil: or the swinging bifilar coil itself is connected by its two suspension wires to the voltaic battery, and the fixed coil is a closed circuit in itself; in that case, a current is induced in the fixed coil. In both cases, an electrodynamic force is yielded which changes the oscillation of the bifilar coil in the same way.

The *observation* of these changes in oscillation, as a result of an induced current, and of the *electrodynamic* reciprocal action between the induced and inducing wire coils, which is dependent on that induced current, according to Ampère's law, must be carried out, however, in an altogether *different* way from the observations with the dynamometer described in the preceding Section. *Observations of the decrease of the arc of the oscillations* must replace the previous *observations of position* on the dynamometer. The necessity of this altered method of observation is easily shown, as follows.

The electrodynamic reciprocal action of the two coils, which is to be observed with the electro-dynamometer, consists, according to Ampère's law, of a rotational moment, which acts on the swinging bifilar coil and corresponds to an altered *rest position* of this coil. However, this *rest position* of the bifilar coil can not be directly observed when the coil is swinging, but can only be determined from several observations, which diverge from one another as to period of oscillation, that is, only under the precondition, that in the interim, the external forces acting on the coil, have remained *constant*, or have changed continuously and *proportionally* over *time*. Therefore, if the electrodynamic influence which occurs on the swinging coil as a result of the induced current, *reverses itself from oscillation to oscillation*, then the rest position of the coil, as determined from a system of observations during the oscillation, will be *unchanged* despite the presence of the electrodynamic influence. Observation shows, in fact, that the latter occurs, that the electrodynamic influence, if it actually exists as a result of an induced current, would thus have to reverse itself from oscillation to oscillation, and cannot be investigated by means of mere *observations of position* on the dynamometer.

Now, if such an electrodynamic influence on the swinging coil now actually occurs, which reverses itself from oscillation to oscillation: then it will certainly not be discernible by means of determining the rest position of the coil; it must, however, be recognizable in the *arcs of oscillation* of the coil; namely, the size of the arcs of oscillation must *change* from oscillation to oscillation, either always increasing, or always decreasing.

In actuality, empirical results show that, while the calculated rest position of the swinging coil always remains the same, the arc of oscillation always *decreases*, and it emerges from the succeeding experiments, that this decrease actually originates from *electrodynamic* influences and not from extraneous external causes, if the ordinary influence of the resistance of the air is taken into account.

Therefore, in order to observe this second class of phenomena with the electro-dynamometer, it will be necessary for precise measurement of the decrease of the arcs of oscillation, to make *oscillation experiments* with the bifilar coil of the dynamometer, while for purposes of the Ampère electrodynamic phenomena, we could confine ourselves to *deflection experiments* or *observations of position*.

For our purposes, it is of primary importance to indicate that the *observations of oscillation* can be carried out on the dynamometer by the same method, and with just as great precision, as on a magnetometer. First, I wish to present a prefatory series of oscillation experiments which I made with the dynamometer, in which *no* electrodynamic influence occurred, given that no galvanic current whatever was conducted through the instrument and the wire ends even remained unconnected.

The method of setting up these experiments is the same method presented by Gauss in the “Resultaten aus den Beobachtungen des magnetischen Vereins in Jahre 1837,” page 58 ff.,²² and thus it is not necessary to fully cite the original protocols; it will suffice to cite the extract which is derived from these protocols, just as in other locations.

The Meyerstein dynamometer, depicted in Figs. 2, 3, and 4, served for the following observations, where the swinging coil was suspended at the center of the fixed coil, and the telescope was placed about 6 meters from the instrument. The distance of the mirror from the scale was 6,018.6 scale units, and

$$1 \text{ scale unit} = 17.1356''.$$

The observations were made in alternation by different observers, namely, by Dr. Stähelin from Basel, by my assistant Mr. Dietzel, and by me. Each made a set of observations according to the formulation given in *loc. cit.*, page 61,²³ which comprises six instances of going past a designated scale point lying close to the midpoint of the arc of oscillation and seven elongation points. In the following table, each horizontal line gives the results of such a set of observations, namely, the numerical ordering of the oscillation, the corresponding time, the corresponding rest position in scale units, the corresponding arc of oscillation in scale units, and the logarithm of the latter.

²² [N. H. W.] Gauss, *Werke*, Vol. V, page 374.

²³ [N. H. W.] Gauss, *Werke*, Vol. V, page 376.

<i>Observations for determining the period of oscillation and the decrease of the arcs of oscillation of the bifilar coil of the dynamometer in open circuits.</i>				
Oscillation No.	Time	Position	Arcs of Oscillation	Log.
0.	5 ^h 16' 28.53"	457.10	650.80	2.813 448
14.	20' 10.20"	457.38	601.43	2.779 185
25.	23' 4.39"	457.15	564.90	2.751 972
52.	30' 12.50"	457.19	485.28	2.685 992
82.	38' 8.02"	457.29	409.62	2.612 381
109.	45' 16.16"	457.15	353.08	2.547 873
134.	51' 52.08"	457.65	306.70	2.486 714
163.	59' 31.80"	457.41	261.08	2.416 774
189.	6 ^h 6' 23.90"	457.56	226.33	2.354 742
212.	12' 28.22"	457.69	198.68	2.298 154
232.	17' 45.45"	457.63	178.26	2.251 054
254.	23' 33.89"	457.78	157.98	2.198 602
284.	31' 29.30"	457.73	134.17	2.127 655
309.	38' 5.53"	456.55	116.30	2.065 580
328.	43' 6.90"	458.02	105.25	2.022 222
369.	53' 56.24"	457.81	83.68	1.922 622
387.	58' 41.96"	457.90	75.45	1.877 659

If the difference between the first and last time is divided by the number of oscillations, one obtains a rather precise determination of the period of oscillation of the swinging coil, because the correction by reduction to infinitely small arcs contributes only a little in the case of such small arcs of oscillation as occurred here. This approximated period of oscillation is

$$= 15.848\ 65''.$$

If this approximated period of oscillation is used to reduce all the times in the table, by deducting the product of the oscillation number times the period of oscillation, from the first time, then the values contained in the third column of the following table are obtained:

Oscillation No.	Time	Reduced time	Variation from the mean
0.	5 ^h 16' 28.52"	5 ^h 16' 28.53"	+ 0.13"
14.	20' 10.20"	28.32"	- 0.08"
25.	23' 12.50"	28.17"	- 0.23"
52.	30' 12.50"	28.37"	- 0.03"
82.	38' 8.02"	28.43"	+ 0.03"
109.	45' 16.16"	28.66"	+ 0.26"
134.	51' 52.08"	28.36"	- 0.04"
163.	59' 31.80"	28.47"	+ 0.07"
189.	6 ^h 6' 23.90"	28.50"	+ 0.10"
212.	12' 28.22"	28.31"	- 0.09"
232.	17' 45.45"	28.56"	+ 0.16"
254.	23' 33.89"	28.33"	- 0.07"
284.	31' 29.30"	28.28"	- 0.12"
309.	38' 5.53"	28.30"	- 0.10"
328.	43' 6.90"	28.54"	+ 0.14"
369.	53' 56.24"	28.07"	- 0.33"
387.	58' 41.96"	28.53"	+ 0.13"

From the agreement of these reduced values, whose variation from the mean values always remains less than 1/3 second, it is obvious, that the determination of the *period of oscillation* of the dynamometer's bifilar coil is capable of the same rigor and precision as in the case of the magnetometer, in which connection it is to be taken into consideration, that that variation appears to be magnified by the constant variation which is known to always occur between two observers. The determinations of the *rest position* of the swinging coil from the elongation observations in the third column of the first table show great agreement, as proven by the following overview of their deviations from the mean values, expressed according to their arcs:

- 6.3"	+ 3.1	+ 4.5
- 1.5"	- 1.0	- 15.8
- 5.5"	+ 1.5	+ 9.4
- 4.8"	+ 3.8	+ 5.8
- 3.1"	+ 2.7	+ 7.4
- 5.5"	+ 5.3	

One could not wish for greater agreement of all observations of position, particularly when one takes into consideration, that the telescope stand was placed on the wooden floor of the room, where, it is evident, the orientation of the telescope could easily be somewhat altered by footsteps on the floor.

Lastly, it remains for us to consider the *decrease in the arcs of oscillation*. The individual sets of observations succeed each other, in part, in such a short time, that the decrease in the arcs of oscillation in the interim is not large enough to give a precise determination of the ratio between two successive arcs of oscillation. Hence the logarithms of this ratio may be determined, by, instead of dividing the difference of each two immediately successive logarithm of the arcs of oscillation, dividing the difference between the first and fifth, the second and sixth, and so forth, by the number of oscillations in between. One then obtains from the above 17 sets of observation, instead of 16

values, only 13 values, but more precise values of the *logarithmic decrement*, namely, the following. Before each value the oscillation number is noted, to whose mean it appertains.

Oscillation No.	Logarithmic decrement	Variation from the mean
41.	0.002 452	+ 0.000 038
$61 \frac{1}{2}$.	0.002 435	+ 0.000 021
$79 \frac{1}{2}$.	0.002 433	+ 0.000 019
$107 \frac{1}{2}$.	0.002 425	+ 0.000 011
$135 \frac{1}{2}$.	0.002 408	- 0.000 006
$160 \frac{1}{2}$.	0.002 424	+ 0.000 010
183.	0.002 405	- 0.000 009
$208 \frac{1}{2}$.	0.002 397	- 0.000 017
$236 \frac{1}{2}$.	0.002 390	- 0.000 024
$260 \frac{1}{2}$.	0.002 398	- 0.000 016
280.	0.002 384	- 0.000 030
$311 \frac{1}{2}$.	0.002 400	- 0.000 014
$335 \frac{1}{2}$.	0.002 427	+ 0.000 013
Mean = 0.002 414.		

Thus there results a mean *decrease in the arcs of oscillation*, according to which the size of the arc, after 124.7 swings, or after 32 minutes 56 $\frac{1}{3}$ seconds, declines by half. The agreement of the partial values proves, that even these small decreases in the arcs of oscillation can be rigorously measured.

On the same day, immediately before the series of observations just described, another similar series of observations was made under altogether the same external conditions, merely with the difference, that the two ends of the fixed coil were connected with a battery of three small Grove's elements, exactly as in Section 4, and that the free ends of the suspension wires of the bifilar coil were linked to each other. More precise information about the current conducted through the fixed coil, was provided by observation of the deflection which this coil itself produced on the *mirror magnetometer* (described in Section 3), which was placed 583.5 mm north of the coil. This observed deflection of the mirror magnetometer is noted in the last column of the following table. The value of the scale unit of this magnetometer depends on the horizontal distance of the mirror from the scale, which was = 1,301 scale units. The observer and the methods of observation were the same. The following table gives the extract of this series of observations exactly as the preceding table gives the other.

Observations for determining the period of oscillation and the decrease of the arcs of oscillation of the bifilar coil of the dynamometer when a current from three Grove's elements is passing through the fixed coil, while the conducting wire of the bifilar coil was closed.					
Oscillation No.	Time	Position	Arcs of oscillation	Log.	Deflection of mirror magnetometer
0.	3 ^h 29' 44.88"	464.05	764.10	2.883 150	108.50
9.	32' 7.03"	474.44	679.15	2.831 966	
18.	34' 29.58"	464.23	604.05	2.781 073	
35.	38' 50.17"	464.07	484.15	2.684 980	108.60
47.	42' 9.10"	464.20	414.60	2.617 629	
57.	44' 47.66"	464.25	365.50	2.562 887	
74.	49' 16.79"	464.22	292.27	2.465 784	
85.	52' 10.80"	464.30	253.30	2.403 635	
103.	56' 56.11"	464.40	200.80	2.302 764	
118.	4 ^h 0' 53.43"	464.25	165.56	2.218 955	108.95
130.	4' 3.26"	464.37	141.37	2.150 357	
143.	7' 28.90"	465.23	119.33	2.076 750	
157.	11' 11.11"	464.96	100.49	2.002 123	109.20
179.	16' 59.23"	465.20	75.59	1.878 464	
196.	21' 28.65"	464.88	60.58	1.782 329	190.40
210.	25' 10.23"	464.96	50.08	1.699 664	

For this series of observations, which is otherwise very similar to the preceding one, I confine myself to considering the decrease in the arcs of oscillation. The logarithm of the ratio of two successive arcs of oscillation, or the logarithmic decrement, is to be determined here by dividing the difference between the first and fourth, the second and fifth, and so forth, logarithm by the number of the oscillations in between. From the 16 sets of observation above, this yields 13 values of the logarithmic decrement, as contained in the following table, with the addition of the number of oscillations to whose mean each appertains.

Oscillation No.	Logarithmic decrement	Variation from the mean
17 $\frac{1}{2}$.	0.005 662	+ 0.000 042
28.	0.005 640	+ 0.000 020
37 $\frac{1}{2}$.	0.005 595	- 0.000 025
54 $\frac{1}{2}$.	0.005 620	0.000 000
66.	0.005 631	+ 0.000 011
80.	0.005 655	+ 0.000 035
96.	0.005 610	- 0.000 010
107 $\frac{1}{2}$.	0.005 628	+ 0.000 008
123.	0.005 650	+ 0.000 030
137 $\frac{1}{2}$.	0.005 560	- 0.009 060

$154 \frac{1}{2}$.	0.005 549	- 0.000 071
$169 \frac{1}{2}$.	0.005 555	- 0.000 065
$183 \frac{1}{2}$.	0.005 707	+ 0.000 087
Mean = 0.005 620.		

Thus there results a mean *decrease in the arcs of oscillation*, according to which the size of the arc, after 53,564 swings, or after 14 minutes 8.187 seconds, declines by half. Here too the agreement of the partial values attests to the rigor of the measurement, and it is not remarkable that at the end, where the arcs of oscillation had become very small, the differences appear somewhat larger.

The difference which occurs between this latter determination of the logarithmic decrement and the previous one, is based, not on different external conditions influencing the swinging coil, for these remain completely the same, but on the *inducing* influence of the fixed coil on the swinging coil, which constitutes the sole difference between the first and second series of experiments. Both series of experiments were repeated on several days, and not only yielded almost exactly the same difference in values of the logarithmic decrement, but also yielded nearly equal absolute values for both decrements, whereby no doubt remains, that an induction of galvanic currents actually takes place in the closed bifilar coil by means of the galvanic current in the fixed coil: in fact, an induction whose strength was such that the effect of the induced current which is visible in the decrease of the arcs of oscillation, is susceptible of precise measurement.

11.

After this demonstration of the *practical* usefulness of the electro-dynamometer for displaying the phenomena of voltaic induction, *secondly*, we proceed to derive some *lawful determinations* for these phenomena from the observations of the oscillations and of the decrease of the arcs of oscillation of the bifilar coil.

First, it has already been noted, that the *changing magnitude* of the arcs of oscillation as a result of the induced currents, given an unchanged mean position of the bifilar coil, proves that the direction of the induced current changes with the *direction of motion* of the swinging bifilar coil, and that consequently opposite currents are induced by means of opposite motions, as is also the case in magnetic induction.

Second, the *decrease* in the arcs of oscillation proves, that as parallel elements of the inducing wire *approach*, a current opposite to that inducing wire is induced; as parallel elements *withdraw*, a current *in the same direction* as that in the inducing wire is induced. If the opposing relation of the current directions of the inducing and induced currents existed, there would have to result a continuous *increase* in the arcs of oscillation. This determination as well is analogous to the one empirically established for magnetic induction.

Third, the *geometric law* of the decrease in the arcs of oscillation due to the induced current, proves that the intensity of the induced current is proportional to the *velocity* of the inducing motion; for the geometric law of the decrease of arcs of oscillation proves that the force which produces this decrease, i.e. the intensity of the induced currents, always remains proportional to the magnitude of the arcs of oscillation: it is known, however, that the magnitude of the arcs of oscillation of an *isochronous* swinging body is always proportional to the velocity it reaches in the corresponding moments of its period of oscillation.

Fourth, as for the lawful determination of the *absolute* strength of the voltaic induction, we wish lastly to derive the following principle from observations on the dynamometer.

The *voltaic induction* is equal to the *magnetic induction* in the oscillating closed circuit bifilar coil, when the former is elicited by a galvanic current conducted through the fixed coil, the latter elicited by magnets which are located in a position with respect to the bifilar coil such that when a current goes through the bifilar coil, the *electrodynamic* rotational moment of that current is equal to the *electromagnetic* rotational moment of these magnets.

By means of this principle, as can easily be seen, the determination of voltaic induction with the help of known *electromagnetic* and *electrodynamic* forces is reduced to the laws of magnetic induction, which have already been investigated more precisely by other means. At the moment, admittedly, in order to prove this principle, I can only give a few measurements carried out with the dynamometer, which were made under circumstances in which no precise determinations down to small fractions were possible; however, these measurements may be regarded as sufficient for the present, because, if the foregoing principle were incorrect, there would be no basis for that approximate agreement which undoubtedly arose from the observations. For a more refined test of the foregoing principle, all the involved measurements would have to be carried out with greater precision. However, in order to set up all the conditions fully appropriately for attaining this uniform precision, it would be necessary to prepare special instruments simply for this purpose, which up to now it has not been possible for me to do.

Here I will briefly assemble the results of the observations, without going into the details of the observations themselves, which generally conformed to those of the preceding observations.

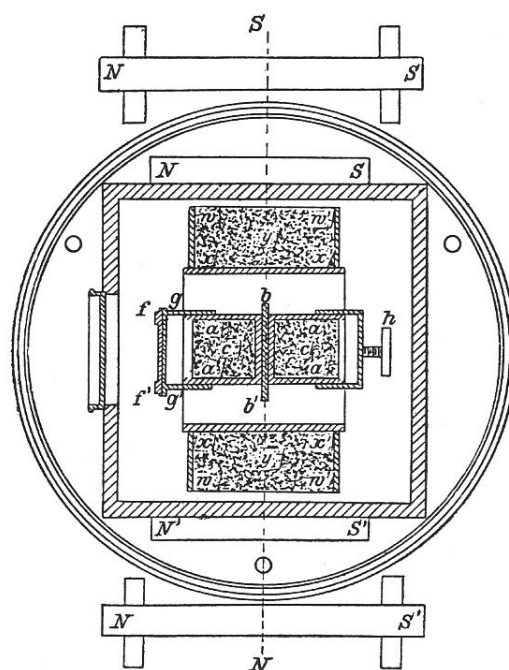

Fig. 4.

The *first* series of observations concerned measurement of magnetic induction. This is exactly the series for which conditions could be shaped least favorably, and which accordingly set narrower limits to the precision of the entire determination of measure, which under somewhat more favorable conditions could have easily been significantly extended. That is, the bifilar coil of the dynamometer described in Section 1 and depicted in Figs. 2, 3 and 4, was made a closed circuit

and put into oscillation, while outside the casing which protected the swinging bifilar coil from the air, several small magnets NS , $N'S'$ (Figure 4) were fixed in the position in which they induced the strongest *magneto-electric currents* in the swinging bifilar coil. Namely, all of these small magnets together lay perpendicular to the magnetic meridian passing through the axis of the bifilar coil, i.e., symmetrically north and south of the bifilar coil, and their corresponding poles were thereby turned toward the same side, as the diagram shows, in which N and N' denote the north poles, S and S' the south poles. Then the oscillations of the bifilar coil, as earlier, were observed, starting from the moment when they could be measured by means of the scale, until they became too small for precise determination of the decrease of the arcs of oscillation. These observations were calculated in the same way as above, and yielded the *logarithmic decrement* for the decrease of the arcs of oscillation

$$= 0.002\ 638.$$

The same series of experiments was once again repeated, with the sole difference, that the bifilar coil was unclosed, and there resulted for the *logarithmic decrement* of the decrease of the arcs of oscillation the following somewhat smaller value:

$$= 0.002\ 541.$$

The slight difference between these two values,

$$= 0.000\ 097,$$

is the effect of the *magneto-electric currents*, which were induced in the swinging, closed-up bifilar coil by means of the fixed magnets. The greatest care was taken to determine this small difference with the utmost possible precision, and the experiment leaves nothing more to be desired in that respect; nevertheless, it is in the nature of the smallness of the difference, that, as the repetitions of the experiments showed, it must be considered as 6 to 8 percent uncertain.

The *second* series of experiments concerned the *electromagnetic* rotational moment. The small magnets remained undisturbed in their place, while a weak current was conducted from a constant voltaic battery; this battery's current passed as well through a *galvanometer*, by means of which its intensity was measured. Now the *rest position* of the bifilar coil was observed, alternately, when the voltaic battery was closed and when it was open. From a series of repetitions, after the reduction of the results to the same current intensity (which had varied only very little), there resulted, with great agreement, the difference

$$= 19.1 \text{ scale units.}$$

This difference is a measure of the *electromagnetic* rotational moment, which the magnetic rods mentioned above exerted on the current in the bifilar coil.

The *third* series of experiments concerned the *electrodynamical* rotational moment. The small magnets were distanced, and the two wire ends of the fixed coil of the dynamometer were connected to a strong voltaic battery, while the same weak current of a constant voltaic battery was conducted through the bifilar coil, as in the previous series. The intensity of both currents was measured by means of a *galvanometer*.²⁴ Now, as in the previous series of experiments, the *rest position* of the bifilar coil was observed, alternately when the voltaic battery was closed and when it was open. From a series of repetitions, after the reduction of the results to the same current intensity, there resulted, with great agreement, the difference

$$= 101.9 \text{ scale units.}$$

This difference is a measure of the *electrodynamical* rotational moment, which the strong current in the fixed coil exerts on the weak current in the bifilar coil.

Lastly, the *fourth* series of experiments concerned *voltaic induction*. The bifilar coil was closed up and put into motion, while the current of the same voltaic battery was conducted through

²⁴ [N. A.] Both currents originated from the same constant battery, and their differing intensity in the two coils was effected by means of a division of the current.

the fixed coil of the dynamometer, as in the previous series of experiments. Then the oscillations of the bifilar coil were observed just as in the first series of experiments, and from this the *logarithmic decrement* of the decrease in the arcs of oscillation was calculated. After reduction to that current intensity in the fixed coil, on which the value of the *electrodynamic* rotational moment found by means of the preceding series of experiments is based, this decrement resulted

$$= 0.005\ 423.$$

The same series of experiments was once again repeated with the sole difference, that the bifilar coil was open, and the following smaller value resulted for the *logarithmic decrement* of the decrease in the arcs of oscillation:²⁵

$$= 0.002\ 796.$$

The difference between these two values,

$$= 0.002\ 627,$$

is the effect of the *voltaic induction*, which took place in the closed and oscillating bifilar coil, by means of the current in the fixed coil.

Since, therefore, the *electrodynamic* force of our current in the fixed coil, after the *third* series of experiments, was not equal to the *electromagnetic* force of our magnets in the *second* series of experiments, but were in the ratio of

$$101.9 : 19.1,$$

the forces of the two *induced currents*, induced under altogether the same conditions in the bifilar coil, should also not be equal, but should likewise be in the ratio of

$$101.9 : 19.1.$$

If, however, the intensities of the currents induced in the swinging bifilar coil stand in the given ratio, then, from the reciprocal action of these currents with those galvanic and magnetic forces producing them, and therefore proportional to them, will have to emerge an attenuation of the oscillations of the bifilar coil, whose *logarithmic decrements* are in the ratio of the squares of 101.9 : 19.1, i.e., like

$$28.5 : 1.$$

Instead of that, from the observations of the decrease of the arcs of oscillation, we have found in both cases the ratio of the portions of the logarithmic decrement stemming from the induced current according to the *fourth* and *first* series of experiments to be

$$0.002\ 627 : 0.000\ 097 = 27.1 : 1,$$

a ratio differing from the calculated one by about 5 percent; the small logarithmic decrements proceeding from the *magneto-electric* currents in the observed cases, as already mentioned above²⁶ on page 63,²⁷ can no longer be relied upon.

12.

An induced current of equal strength to the inducing current.

The *constancy* of the logarithmic decrement of the swinging bifilar coil under the influence of a constant current in the fixed coil, and of the currents thereby induced in the swinging bifilar coil, already resulted²⁸ on page 61²⁹ in the law for induction, that the intensity of the induced

²⁵ [N. A.] This value would be still smaller, if at the same time, the current in the fixed coil were interrupted, because this current, even given an open bifilar coil, still induced currents in the brass mounting of the coil during the oscillation, exactly as was the case in the first series of experiments with the magnets, which, however, worked far more weakly.

²⁶ [N. E.] Regarding the 6-8% uncertainty.

²⁷ [N. E.] Page 105 of Weber's *Werke*, Vol. 3.

²⁸ [N. E.] Third law at the beginning of Section 11.

current is proportional at any moment to the *velocity* of the swinging coil at that moment. If hereby this law is now placed beyond doubt, then it follows that, in the case of a given *constant* inducing current, one could arbitrarily strengthen the current *induced* by it, if one increased that *velocity*, and that there would have to be a velocity, at which the *intensity of the induced current would be just as strong as that of the inducing current*. It may not be uninteresting to give a more precise *determination* of this velocity. This determination can easily be obtained, if one (1) calculates from the measured arcs of oscillation of our coil and from its arcs of oscillation, likewise measured according to known laws, the *velocity* which the coil possesses in the center of its oscillation; (2) if one calculates, from the likewise measured values of the logarithmic decrement caused by the voltaic induction, the *deflection* of the coil, which would be produced by the force which retards the velocity of the swinging bifilar coil at the moment when it finds itself in the center of its oscillation, if it continues uniformly in the same direction; and (3) lastly, if a current is put through the bifilar coil, and the intensity of this current is varied until the electrodynamic deflection of the coil as a result of the reciprocal action of this current and of the constant current in the fixed coil is equal to that deflection in (2), and if the *ratio* of the intensities is then determined. – It is then clear that, when the velocity of the swinging coil is increased according to the ratio of these intensities, the induced current will be equal in strength to the inducing current at the moment when the coil finds itself in the center of its arc of oscillation. In this way it turned out that the bifilar coil of the dynamometer described in Section 1 would have to be turned around its perpendicular axis of rotation

31 times

in one second, in order for the current *induced* by the arbitrarily strong or weak current of the fixed coil of this instrument to have the *intensity of the original current* at the moment when both coils were perpendicular to one another. At this velocity of the coil's rotation, the greatest linear velocity of the current elements would amount to 6.5 meters or about 20 feet in one second, since, according to page 7,³⁰ the radius of the bifilar coil was 33.4 millimeters.

13.

Determination of the duration of momentary currents with the dynamometer, along with application to physiological experiments.

In order to portray and to measure the reciprocal action of two conducting wires with the help of the dynamometer, no strong currents are required, as the data presented prove; on the contrary, weak currents suffice, which, if other devices are used, are barely perceptible, such as, for example, the induced currents produced by the oscillations of the bifilar coil, according to Section 10, which were barely visible without an optical device. This circumstance is of practical importance, because these experiments thereby received a far greater expansion, and the way was paved for the most manifold applications of the dynamometer, especially to *galvanometric* determinations as well. A compass or a magnetometer is called a *galvanometer* when it is equipped with a multiplier, because it serves to measure the intensity of the galvanic currents which are led through the multiplier wire. The measurement of the intensity of galvanic currents is hereby based, *not on purely galvanic*, but on *electromagnetic* effects. By the same right a *Volta-meter*, too, deserves the name of a *galvanometer*, because it likewise serves to measure the intensity of galvanic currents which are conducted through the Volta-meter; it is merely that the latter is an *electrochemical* galvanometer, the former an *electromagnetic* one. Now, the *electrodynamometer* is

²⁹ [N. E.] Page 103 of Weber's *Werke*, Vol. 3.

³⁰ [N. E.] Page 36 of Weber's *Werke*, Vol. 3.

also a *galvanometer*, because it serves to measure the intensity of galvanic currents which are conducted through it; it is, however, a *purely galvanic* or *electrodynamic* one, because it is the reciprocal action of the galvanic currents itself which is used therein for measuring the current intensity, and hence it merits even preferentially the name *galvanometer*.

Nevertheless, it does not seem possible to ascribe any great practical importance to the *electrodynamometer*, if it is no longer a matter of testing the fundamental electrodynamic laws, but merely of *galvanometric* determinations, because the multifarious apparatus of the Volta-meters and of the electromagnetic galvanometers for measuring the intensity of galvanic currents already performs such good and convenient service, that no reason presents itself to replace this already utilized instrument with a new one. As long as it is simply a matter of objectives which have already been attained with the latter instruments, or can be attained with them, a new instrument like the dynamometer can, in fact, have no great practical importance attached to it. However, things are different in those cases, where the existing devices are inadequate, as, for example, when it is a matter of determining the current intensity *at particular moments*.

That is, the sine or the tangent of the deflection of the magnetic needle in the sine or tangent-galvanometer only gives a correct measure of the current intensity in the multiplier *at a definite moment*, if the current in the multiplier acting on the needle is *constant*; if, on the contrary, its intensity is *variable*, then the intensity of the current for a particular moment cannot be derived at all from the deflection of the magnetic needle, or only by means of calculating with the help of a given law designed for those variations. Of course, we may then let the current act on the needle for only a *moment*, but the deflection of the needle elicited by this momentary influence, even if it is large enough for precise observation and permits refined measurement, in no way suffices per se for the determination of the current intensity at that moment; on the contrary, knowledge of another element is required, namely, knowledge of the *duration* of that momentary influence, which cannot be achieved with the instrument. Only when one knows the *amount* of electricity which the momentary current puts through, and the *time* in which this electricity has gone through a cross-section, can the intensity be determined by dividing the former by the latter. However, from the deflection of the needle elicited by that momentary influence, only a determination of that amount of electricity can be derived; the time remains undetermined.

Now, the *dynamometer* serves in such cases essentially to *supplement* the *electromagnetic galvanometer*, for both instruments give us *two intrinsically different*, mutually independent determinations, from which *the two unknown elements*, on which the current intensity depends, can be derived. The *difference* of the determinations obtained with the two instruments already manifests itself, when one conducts continuous *constant* currents of *differing intensity* through a circuit, in which the usual *galvanometer*, and also the *dynamometer*, is included, and the *angle of deflection* is observed, at which for each of these currents, equilibrium exists on these instruments. These angles of deflection increase on both instruments with the intensity, but according to different laws; for the tangents of the angles of deflection of the *dynamometer* are, as was proven in Section 2, proportional to the *squares* of the tangents of the angle of deflection of the *magnetometer*.

That *difference* in the determinations provided by the two instruments shows itself even more remarkably, if a *constant* current, as just described, is put through both instruments, and the corresponding deflections of both are observed, and then, without changing the current intensity, simply the *direction* of the current in all the conducting wires of the two instruments is *reversed* with the help of a commutator; it is known, that after this reversal of the direction of the current direction in the multiplier, the multiplier's *magnetic needle* is deflected just as far as before the reversal, but to the *opposite* side. In the *dynamometer* this does not take place, but rather, the deflection occurring before the reversal of the current remains *unchanged* even after the reversal of the current, so that, provided that the reversal of the current has actually been momentary, without

interruption, *no influence at all* on the dynamometer is to be perceived from this reversal. The dynamometer in this case acts as an *electromagnetic* galvanometer would act, if, at the moment when the current in the multiplier were reversed, the *poles of the needle were also switched*, assuming that the needle, like the bifilar coil of the dynamometer, possessed a definite directional force independent of the state of its poles. This sameness of the effects of positive and negative currents in the dynamometer in this easily executed experiment, ought to arouse all the more attention, the more one is accustomed to see opposite currents correspond to opposite effects.

This experimentally proven *difference* in the determinations provided by the two instruments can now easily be more precisely *defined*. The direct effect of the current passing through the conducting wires of both instruments is a *rotational moment*, which strives to put the compass or bifilar coil on which it acts, into a rotational motion. This rotational moment is proportional in the *magnetic galvanometer* to the intensity i of the current acting on the needle, and to the magnetic moment m of the needle, which is acted upon, and is thus represented by the formula

$$a \cdot mi,$$

in which, if we confine ourselves to small angles of deflection, a is to be considered as a constant to be determined once and for all for each instrument. The effect of this rotational moment in the time element dt is then expressed by the product

$$ami \cdot dt$$

and is equal to the product of the rotational velocity, in which the rotatable body is thereby put, with the moment of inertia of this body.

In the *dynamometer*, on the contrary, the rotational moment is proportional to the intensity i of the current in the fixed coil, which acts on the bifilar coil, and also to the intensity i of the current in the bifilar coil itself, which is acted upon, and is thus represented by the formula

$$b \cdot i^2,$$

where b , if we confine ourselves to small angles of displacement, denotes a constant to be determined once and for all for each dynamometer. The effect of this rotational moment in the time element dt is thus expressed by the product

$$bi^2 \cdot dt,$$

and is likewise equal to the product of the rotational velocity produced with the moment of inertia of the rotatable body.

Now, if this current persists uniformly during the short time from $t = 0$ to $t = \mathcal{G}$, and if the inertial moment of the needle and of the bifilar coil are denoted with p and q , then the *angular velocity* which is thereby produced is

$$\text{for the needle} = \int_0^{\mathcal{G}} \frac{a}{p} \cdot midt = \frac{am}{p} \cdot i \mathcal{G}$$

$$\text{for the bifilar coil} = \int_0^{\mathcal{G}} \frac{b}{q} \cdot i^2 dt = \frac{b}{q} \cdot i^2 \mathcal{G}.$$

If both instruments were previously at rest, then they are put into oscillation by the transmission of this angular velocity, and if s and ζ denote the *periods of oscillation* of the two instruments, then, according to well-known laws of oscillation, if no attenuation takes place, and if the time interval \mathcal{G} , in which the needle and the bifilar coil receive that angular velocity, is so small, that the *disturbance* itself during this small time interval, as with a *shock*, does not need to be taken into consideration, then the *rotational velocity* for any moment at the end of time t is expressed by

$$\frac{e\pi}{s} \cdot \cos \frac{\pi}{s}(t - \mathcal{G}) \text{ and } \frac{\varepsilon\pi}{\zeta} \cdot \cos \frac{\pi}{\zeta}(t - \mathcal{G}),$$

where e and ε denote the *elongation lengths*, which can be determined for both instruments by *observation*. If now the first moment after the cessation of the current is substituted for t , that is, $t = \mathcal{G}$, then the velocities originally transmitted by the current to the two instruments are obtained:

$$\frac{am}{p} \cdot i \mathcal{G} = \frac{e\pi}{s}, \quad \frac{b}{q} \cdot i^2 \mathcal{G} = \frac{\varepsilon\pi}{\zeta},$$

or one has two equations for determining the *current intensity* i and the *duration of the current* \mathcal{G} , by means of which they can be calculated from the *measured deflections* of both instruments e and ε , namely:

$$i \mathcal{G} = \frac{\pi p}{ams} \cdot e, \quad i^2 \mathcal{G} = \frac{\pi q}{b\zeta} \cdot \varepsilon,$$

where $\pi p/ams$ and $\pi q/b\zeta$ denote constants to be determined once and for all. The sought-for *current intensity* i results from this:

$$i = \frac{am}{b} \cdot \frac{q}{p} \cdot \frac{s}{\zeta} \cdot \frac{\varepsilon}{e},$$

and the sought-for *duration* of this current:

$$\mathcal{G} = \frac{\pi b p^2 \zeta}{a^2 m^2 q s^2} \cdot \frac{e^2}{\varepsilon}.$$

Since the *periods of oscillation* of the two instruments s and ζ can be directly determined, it is merely necessary for the complete determination of the *constants* of both instruments, to put through both instruments a constant standard current, whose *intensity* = 1, and to observe the tangents of the *angles of deflection* e' and ε' , for which equilibrium then exists. The tangents of the angles of deflection are then, according to well-known laws, to be equated with the ratios of the deflecting *rotational moments* for the current intensity = 1, namely

$$am \quad \text{and} \quad b,$$

to the *directional forces* of the compass and the bifilar coil, namely

$$\frac{\pi^2 p}{s^2} \quad \text{and} \quad \frac{\pi^2 q}{\zeta^2},$$

thus:

$$e' = am \cdot \frac{s^2}{\pi^2 p}, \quad \varepsilon' = b \cdot \frac{\zeta^2}{\pi^2 q}.$$

If these values are substituted in the above equations, one obtains

$$i \mathcal{G} = \frac{s}{\pi} \cdot \frac{e}{e'}, \quad i^2 \mathcal{G} = \frac{\zeta}{\pi} \cdot \frac{\varepsilon}{\varepsilon'},$$

and consequently

$$i = \frac{\zeta}{s} \cdot \frac{e'}{\varepsilon'} \cdot \frac{\varepsilon}{e}$$

$$\mathcal{G} = \frac{1}{\pi} \cdot \frac{s^2}{\zeta} \cdot \frac{\varepsilon'}{e'^2} \cdot \frac{e^2}{\varepsilon},$$

in which by means of a one-time observation of the deflections e' and ε' as well as the period of oscillation of the compass and the bifilar coil s and ζ , the constant coefficients ζ/s , e'/ε' , s^2/ζ and ε'/e'^2 are determined for ever. Thus it follows from this, that that the observations simultaneously made on both instruments of the deflections e and ε supplement each other, by jointly providing complete data for determining the *intensity* and the *duration* of a momentary current, while each one, considered individually, acquaints us with neither the one nor the other.

The cases where this complete determination of momentary currents, attainable by means of simultaneous use of both instruments, finds useful *applications*, are not far to seek; they present themselves in a manifold way. *Momentary* currents, for example, are frequently used for *physiological* experiments, in order to investigate the *influence of galvanism on the nervous system*; for it turns out that a continued action of the galvanic current very quickly deadens the nerves through which it goes, particularly when it is a *sensory nerve*, so that no extended series of rapidly successive experiments can be carried out in this manner, which becomes possible, if the current is always allowed to go through the nerve only for a moment. These highly interesting observations, however, can lead to no definite results, without a *knowledge of the currents* which elicit those effects, especially of their *intensity* and their *duration*. A thorough investigation of the physiological effects of galvanic currents on the nervous system hence requires the complete determination of these two elements, which, however, can only be achieved according to the just-developed method of simultaneous observations of the *galvanometer* and *dynamometer*. In any case, it is an interesting task for the physiology of nerves, to establish the time *limits* for how long a current must act on the nerves, in order to elicit a definite effect, and how this necessary time interval varies with the strength of the current. I venture to hope that the electro-dynamometer will be used for the purpose presented, especially since in the local *Physiological Institute*, some experimental tests have already been made with good results, which will be communicated on another occasion. At present, I will confine myself above all to applications which can be made in the realm of physics itself, specifically, above all in the field of pure *electrical theory*.

14.

Repetition of Ampère's fundamental experiment with static electricity, and measurement of the duration of the electrical spark during discharge of a Leyden battery.

Ampère's fundamental experiment regarding the reciprocal action of two conducting wires at a distance had up to now been carried out with a single form of galvanic currents, namely, currents which originated from a voltaic battery. If one now finds oneself justifiably moved to the conjecture, that all galvanic currents, from whatever source they might originate, are subject to the same laws, and that therefore Ampère's law regarding the reciprocal action of two conducting wires would be confirmed for all kinds of galvanic or electrical currents, this confirmation itself is in no way superfluous. Thus far, it already seems important that according to the experiments communicated in the preceding Sections, the Ampère reciprocal action has been proven as well for *magneto-electric* currents and by means of currents induced by means of *voltaic induction*. However, it seems still more important to repeat Ampère's fundamental experiment with *static electricity*, as it occurs in the discharge of a Leyden jar or battery by means of the applied discharge wire, since there are such considerable differences between this current of static electricity and all other galvanic currents, that only empirical experimentation can show, whether Ampère's fundamental experiment can hold good, or not. In particular, so long as empirical experimentation had not decided this question, one could easily conjecture, that either the extremely *short duration* of a current of static electricity, or, given a longer duration, the *discontinuity* of the current might be inherently obstructive to the reciprocal action of two long conducting wires, like those of the two coils of the dynamometer, because it would be possible that the current in one wire had already stopped again while it was just beginning in the other. Experimentation with the *electrodynamometer* has proven, however, that the fundamental Ampère experiment also succeeds with static electricity, of which I will now give a more precise account here.

It is known, that the repetition of Oersted's fundamental experiment with the *static electricity* collected in a Leyden jar is made most reliably, when one end of a wet string is fastened

to the discharging rod, the other end to the conducting wire which forms the multiplier of the *galvanometer*, and the wire's other end is in a conducting connection with the outer coating of the Leyden jar. If the Leyden jar is then discharged with the discharging rod while the wet string hangs on it, a deflection of the magnetic needle is observed in that *direction* which can be predetermined by means of the *electromagnetic* laws. The use of a wet string is, however, not absolutely necessary to this fundamental experiment, but seems to be advantageous only when one wants to directly connect the wire ends of the multiplier of a sensitive galvanometer with the positive and negative conductor of an electrical machine. It is also not necessary to insulate the wires better than for other galvanic circuits. In the first case the use of a wet string was advantageous, because without it, the intensity of the discharge entails the danger of a confluence of the divided electricities which are collected in the battery, by other paths than through all the windings of the conducting wires. This danger is prevented by means of inserting a wet string, which diminishes the intensity of the discharge and nevertheless permits very large masses of electricity to unite with each other in a very short time through the conducting wire.

Now, while the main point of performing Oersted's fundamental experiment with static electricity is simply to conduct very large masses of electricity through the multiplier, whereas *the time* in which the electricity goes through the wire, comes *less* into consideration, the successful execution of Ampère's fundamental experiment essentially rests instead on leading large masses of electricity in *the shortest possible time* through the conducting wire, for which, therefore, the collection of electricity in batteries and the discharge of the batteries by means of a wet string seems especially suited. The effect of equal masses of electricity is always the *same* in the *first* experiment, the amount of time of flow may be smaller or larger, as long as it does not become so large that it requires a considerable portion of the period of oscillation; with the *latter* experiment, however, in conformity with the preceding Section, the effect is to be *inversely proportional* to the transit time. Accordingly, it seems that the use of the Leyden jar along with a wet string must be considered as especially favorable, if not necessary, for our experiment, and hence I have in fact used both in my first experiments.

Thus I joined together for this purpose two wire ends of the two coils of the dynamometer, and led one of the two other wire ends to the outer lining of a Leyden jar, the other to a wet string which was fastened onto the insulated discharging rod. The battery was charged, and lastly, the discharging rod was brought toward the metal knob which was connected with the interior lining of the battery. At the moment when the discharge of the battery through the wet string and through the dynamometer coils took place, the dynamometer, which had previously been at rest, was put into an *oscillation*, which often comprised an arc of several hundred scale units, of which several examples are to be presented forthwith. The observer standing at the telescope could easily determine the *magnitude* of the first elongation and the *side* toward which it occurred.

If thereupon the experiment was repeated, by re-charging the Leyden jar or battery in the same manner, but with the difference, that the wire which was previously connected to the outer lining, was fastened to the end of the wet string of the discharging rod, and the other wire end was instead disconnected from the string and connected to the outer lining of the battery, then the effect was the *same*, not only with respect to the magnitude, but also with respect to its direction, so that, as with ordinary currents, *no difference whatever* took place in the effect of the *positive* and *negative* currents. And this *direction* of the deflection of the dynamometer as a result of the current of static electricity passing through, turned out to be like that which was already *predetermined* by means of Ampère's law. It is hereby proven, that the fundamental Ampère experiment can also be made with a current of static electricity.

It was also of further interest, however, to test whether the use of the wet string was necessary or dispensable for the success of this experiment, as well as whether there might exist any cases at all, where the current of static electricity would yield Oersted's fundamental

experiment, but not Ampère's, or whether with respect to static electricity, both kinds of effects are always associated. For this purpose, more extensive series of experiments are required, than I have undertaken up to now; yet a few preliminary experiments may meanwhile be relevant.

The earlier experiments were repeated, both utilizing the wet string and excluding it, and also in association with the *electromagnetic* experiments, by inserting the multiplier of a magnetic galvanometer into the same circuit which included the two coils of the dynamometer. The latter effect then served as a criterion and a metric, *whether* and *how much* electricity went through the wire circuit when the Leyden jar was discharged. When the wet string was excluded, in order to replace by other means the large resistance which it provided, a fine German silver [Argentan] wire of 0.3-millimeter diameter was wound around two glass columns 3.75 meters distant from each other, in such a way that the individual 7.5-meter-long windings were approximately 40 millimeters from each other, whereby they were completely insulated from one another. The German silver wire formed 32 such windings, and the end of this wire was now led freely through the air to the charged battery. In the following table I assemble the results of two series of experiments for comparison, namely, one in which the current went through the wet string, the other in which the wet string was excluded from the circuit. The electric battery consisted of 4 jars each of about 2 square feet coated surface, which were charged moderately strongly and so uniformly in all experiments as could be discerned on the quadrant electrometer. The string was made of hemp, 320 millimeters long, 4 millimeters thick, and was dipped in water before each experiment.

1. Discharge using the wet string:		
No.	Elongation of galvanometer	Elongation of dynamometer
	= e	= ε
1.	51.75	206.99
2.	56.26	214.94
3.	61.36	236.98
4.	52.68	216.63
5.	55.31	223.88
2. Discharge using the wire circuit, without string:		
6.	7.06	0.85
7.	7.04	0.85

The observations on the *galvanometer* show that, if when using the string, all the electricity went through the circuit, without the string only 7 to 8 parts of it went through, according to which, under the presupposition, that the discharge without the string resulted faster, or at least not slower, than with the string, an effect would be expected of at least 50 parts of the previous amount of electrodynamic effect. This did not occur, however, but instead, as the comparison of the observations presented in the third column under ε shows, the effect was almost six times smaller. Although this latter effect was so small, it was nevertheless clearly perceptible.

The influence which the water exerted when the electricity was conducted through it, seemed to be susceptible of more precise investigation when the wet string was replaced with a glass tube filled with water. Hence a 1,200-millimeter-long, 13-millimeter wide empty glass tube was bent into a U shape and filled with water, inserted between the discharging rod and the rest of the circuit, and the earlier experiments repeated, yielding the following results, with the same charge in the battery as earlier, which prove that water contained in a glass tube could not replace a wet string in this case.

Discharge with a glass tube filled with water:		
No.	Elongation of galvanometer	Elongation of dynamometer
	= e	= ε
1.	4.68	3.23
2.	4.50	1.57

In vain were all precautionary measures which were taken in this experiment and in the preceding one with the exclusion of the wet string, in order to compel the electricity to take its path through the water in the tube, and thence through the German silver wire, in order to diminish the intensity of the charge by means of the resistance of these bodies, and to make all the electricity take its path through the instrument's conducting wires; only a slight portion of the electricity seemed to actually adopt the latter path. If, on the contrary, the glass tube was exchanged for a string of *glass threads*, this string, when it was externally moistened, performed comparable service to the wet string. The discharge through such a 500-millimeter-long string dampened with ammonia gave the following elongations on the galvanometer and dynamometer respectively:

100.55 70.35.

The electricity coming out of a Leyden jar seems to especially spread on the surface of the body, and therefore a moist conductor seems to have more effect, when it externally covers the surface of this body, than when it is enclosed.

Lastly, the results of a series of experiments performed with the wet string may be relevant, in which a battery of 8 jars just like the ones used earlier, and a hemp string of 7 millimeters thickness and 2,000 millimeters length was inserted; this length, however, was gradually shortened to 125 millimeters.

Length of string	Elongation of galvanometer = e	Elongation of dynamometer = ε	$\frac{e^2}{\varepsilon}$
2 000 mm	79.9	65.6	97.3
1 000 mm	76.6	153.0	38.3
500 mm	82.3	293.8	23.0
250 mm	87.3	682.0	11.2
125 mm	93.2	out of scale	
250 mm	82.9	609.1	11.3
500 mm	95.6	422.8	21.6
1 000 mm	95.8	210.1	21.6
2 000 mm	101.5	98.0	105.0

It may be further noted, that, when the string was dipped into *dilute sulphuric acid*, a discharge of the battery gave a deflection of 83 scale units on the galvanometer, while the deflection on the dynamometer itself was too large, when the string length was 2,000 millimeters, to be measured on the scale.

It is easily seen, that a broad field of interesting experiments stands open here, which I have not further pursued, because of the need to subject the amount of electricity in the battery used for the experiments to a direct precise measurement, according to the model given by Ries in his electrical experiments, for which I do not currently have at my disposal the appropriate equipment, and therefore I am postponing this work to a more favorable time.

Meanwhile, however, the last series of experiments performed already shows, apart from the *strength* of the effects, such a degree of *regularity*, that it becomes probable that, in discharging the Leyden battery by means of a wet string, *all the electricity* in fact goes through the conducting wire and forms a current in it which might be comparable in continuity to the current of a galvanic battery.³¹ Were this the case, one could make an important application of the preceding observations, by applying to them the rules developed in Section 13, in order to determine the *duration* of the current which may be considered as equal to the duration of the *discharge spark*, according to an *absolute time metric*. It is well known that Wheatstone effected the determination of the duration of the discharge spark in a completely different manner, and it would be interesting to compare with each other the results found in such different ways. In order to reduce to an *absolute time metric* the *relative time metric* which we have already included for the above experiments themselves in the column headed e^2 / ε , it requires, according to page 68,³² simply an experiment with a constant current passing through both instruments, which I have carried out for this purpose, and have found that the values for e^2 / ε in the table above are to be divided by 1,188,

³¹ [N. A.] Electrodynamical experiments can be arranged with *two dynamometers* in such a way that the electricity is conducted *successively* in one, *simultaneously* in the other, through the fixed and suspended coils. By comparing the results for both instruments, when a battery is discharged through them, it would be possible to investigate more precisely the continuity or discontinuity of the current.

³² [N. E.] Page 114 of Weber's *Werke*, Vol. 3.

in order to obtain the duration of the current in *seconds*. The following table is calculated accordingly:

Length of string	Duration of spark
Millimeters	Seconds
2 000	0.081 9
1 000	0.032 2
500	0.019 3
250	0.009 4
250	0.009 5
500	0.018 2
1 000	0.036 8
2 000	0.088 3

or in mean values:

Length of string	Duration of spark
Millimeters	Seconds
2 000	0.085 1
1 000	0.034 5
500	0.018 7
250	0.009 5

It follows that the *duration of the spark is almost proportional to the length of the string*, as the following overview of the thus *calculated* values and their difference from the *observed* values proves:

Length of string	Calculated duration of spark	Difference from observed value
Millimeters	Seconds	Seconds
2 000	0.081 6	- 0.003 5
1 000	0.040 8	+ 0.006 3
500	0.020 4	+ 0.001 7
250	0.010 2	+ 0.000 7

If one compares the results found by Wheatstone, according to which the duration of the spark by discharges merely through a metallic conductor, is negligibly small in relation to the duration found here, then this stands in complete accord with the proportionality found here between the duration of the spark and the length of the wet discharge string. In any case, the fact that the *motion of the electricity in water* occurs so *slowly*, that the time it requires for the short path of 2 meters amounts to roughly 1/12 seconds, merits particular attention. Apart from the objection derived from the discontinuity of the currents of static electricity (which was already discussed above, and which may be largely diminished or entirely eliminated by means of the influence of the water), it could, of course, be objected against the application of the rule by which these time determinations were made, that the current is most intense in the first moments, and will *gradually decline*, while the above rule can only be applied with precision, when the current always possesses the same intensity during its short duration. If, however, one empirically finds, in this case as well, not the true duration, but that duration which would correspond to a *mean current strength*, the value of the

determination may lose little on this account, because it will generally be of more interest to know the latter duration, than the former. It is also noteworthy that for the same reasons, a similar difference was occasioned in Wheatstone's determination of the duration of the spark, because the spark was extended in a line which as a result of that decrease gradually dispersed without sharp delimitation.

15.

Two investigations in the field of *pure electrical theory* are still to be presented here, for which the use of the dynamometer opens a new path; however, I will not go more precisely into these investigations for the present, because the necessary experiments are still lacking, in order to demonstrate conjointly the method and the results obtained by it. These two investigations concern:

- 1) the determination of the velocity of the propagation of currents, for which up to now merely a few experiments by Wheatstone are in hand, which, however, according to Wheatstone's own statement, have still not led to any certain results;
- 2) the determination of the electromotive force of a galvanic circuit, independent of the polarization of its plates.

The *first* application requires that the bifilar coil is separated from the fixed coil by means of long conducting wires, and in this long circuit a current is produced, whose direction changes as fast as Wheatstone's mirror is rotated. The use of the dynamometer, by comparison with Wheatstone's method, provides the advantage of using galvanic currents instead of common electricity, and the circuit is never interrupted, which was necessary for Wheatstone for producing the spark. The *latter* application is based on the measurement of momentary currents according to Section 13.

16.

Application of the dynamometer to measurement of the intensity of sound vibrations.

It still remains, to describe an application of the dynamometer to researches in another domain of physics, which seems to have a special interest associated with it, because it casts a bright light on a specific aspect of what can be done with this instrument. We possess extraordinarily refined *galvanoscopes*, with which we are in a position to discover and investigate even the weakest currents found in Nature. We need merely recall the fine work of Melloni, in order to place the greatest weight for science in general upon the use of these refined instruments and the traces of electrical motions which we find by means of them. Despite this refinement in the instruments, however, in many cases success has not been achieved in demonstrating electrical currents everywhere we surmise that they exist, perhaps because those instruments, despite their refinement, were not suited to the purpose. This reason deserves all the more consideration, in that *one* sort of current can be demonstrated and exactly described, to which even the finest instruments are insensitive, in the nature of the case. This occurs, when we are dealing with an alternating current, which in very short sequential time intervals *constantly changes its direction*. The alternating opposite actions of the current on the most sensitive magnetic needle must cancel each other, if the magnetism of the needle always remains the same. The phenomena observed by Poggendorff (*Annalen* 1838, Vol. LXV, page 355 ff.), in which this does not seem to occur, originate from a changeability in the needle's magnetism, and, given a very accelerated change in current, would disappear again. Such currents, whose direction changes very rapidly, can thus exist to a great extent in Nature, without us having an inkling of their existence, because we possess no way to discover them. And it is not at all improbable, that such currents exist, for the movement of

electricity in them would differentiate itself from the movement of electricity in the usual currents, only by the fact that the former consists of an *oscillation*, while in the latter, the motion of the electricity is *progressive*. Since the progressive motion of electricity occurs so abundantly in Nature, it is not obvious why, given such great mobility occasional conditions should not also occur, which favor a vibrating movement. If, e.g., light undulations exert an effect on the electrical fluids, and have the power to disturb their equilibrium, it would certainly be expected that these *effects* of light undulations would be structured in time with the same periodicity as the *light undulations themselves*, so that the result would consist of an *electrical vibration*, which, however, we are unable to discover with our instruments. Now, the undulations of light occur so rapidly, that, if the vibrations they elicit follow an equally rapid alternation, we could scarcely hope to observe their effects with any instrument. Slower vibrations also occur in Nature, however, e.g. acoustical ones, and hence the question arises, whether there are not electrical motions in Nature whose origin is due to them, and if there are such motions, in what way we could discover and investigate them.

I want to give at least one example here of such *electrical vibrations*, elicited by sound vibrations, and provide the actual proof of how such electrical vibrations can be observed and investigated with the help of the *dynamometer*, and how the measurable effects of these electrical vibrations can in turn be used to elucidate the sound vibrations from which they originate, and thereby to open a new path for many acoustical investigations, for which we still altogether lack suitable means of measuring the *intensity of sound vibrations*.

In fact, the peculiarity of the dynamometer, which most characterizes it and distinguishes it from all other galvanometers, consists in the fact, that it is *indifferent* to the *direction* of the current acting upon it, while other galvanometers undergo opposite effects, given opposite directions of the currents. Attention was already called to this in Section 13 above. We can express this succinctly by saying that the dynamometer with respect to *constant* currents gives a measure for the *square of the current intensity*, while other galvanometers provide a measure for the current intensity itself.

From this characteristic property of the dynamometer, it is now obvious, that the rapidly successive actions of the opposed currents do not, as in an electromagnetic galvanometer, cancel each other, but rather must be additive; and that in virtue of its nature the dynamometer consequently finds its true purpose in bringing to light such otherwise unobservable currents.

Now, the *sound vibrations* are mostly, of course, contained in such narrow, almost microscopic boundaries, that we can scarcely hope to use them to elicit electrical vibrations whose boundaries have the breadth necessary to register an effect upon the dynamometer. If, however, we calculate the absolute velocities, with which the resonating bodies move in the middle of their vibrations, it turns out that these velocities, considering the short duration of the vibrations, are not entirely inappreciable, despite the small oscillation curves, but often amount to a foot or more in one second. Building upon this, I have carried out an experiment so that it seemed the first to be capable of producing results. I prepared a sounding-rod of steel (*aaa*, Figure 13) and let it harden,

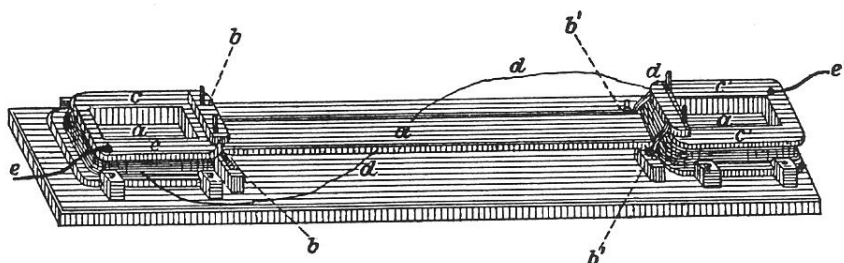

Fig. 13.

magnetized it, and fastened its nodal lines at the end-points b, b, b', b' between screw-heads as axes of rotation, as I have described in *Poggendorff's Annalen* 1833, Vol. XXVIII, page 4,³³ and divided it into three sections simultaneously vibrating toward opposite sides. Hence the two end sections made their vibrations simultaneously in the same direction, alternately upward and downward. The free magnetism, which is disseminated in these rods, can be thought of as disseminated on the surface of the rod, according to Gauss's ideal distribution, which represents the actual distribution in all outward effects; and, specifically in the case of strong magnetization, the free north magnetism must be thought of as almost entirely on the surface of one vibrating end-section, the free south magnetism almost entirely on the surface of the other vibrating end-section, and indeed the closer to the end, the greater the concentration, i.e., exactly the most [magnetism] where the sound vibrations are the greatest. I wound these two vibrating end-sections with strong inductors ccc and $c'e'c'$ made of fine copper wire, which, however, never touched the rod, so that its vibrations would not be inhibited. In addition, there was a gap in the windings on the sides of the inductors turned toward each other, through which the ends of the rod were inserted into the inductors. The windings of the inductors were parallel to each other and lay in a plane perpendicular to the sound vibrations of the sounding-rod. The two inductors were connected to each other with two of their wire ends $dddd$, so that they formed spirals wound in opposite directions. Their two wire ends ee and $e'e'$ were connected with two wire ends of the fixed and moveable coils of the dynamometer, whose other two wire ends were connected to each other. The dynamometer was completely at rest. After everything had been prepared in this way, the sounding-rod was made to vibrate strongly by means of a sharp rap at its midpoint with a soft clapper. There appeared at once a deflection of the bifilar coil of 20 to 30 scale units, and thereupon, when the maxima and minima of the vibration curve of the bifilar coil, which was vibrating from then on, were recorded, it was seen, that the state of rest calculated from this, around which the vibration occurred, was altered, but that it quickly returned again to its original state as the sound vibrations decreased in strength. I would note that I elongated the bifilar coil by several hundred scale units, letting the sounding-rod vibrate only so long, as the elongation was increasing, while on the other hand I deadened the sounding-rod, while the bifilar coil swung back again, and struck the sounding-rod again as soon as the bifilar coil began to move in the original direction, and so forth.

It hardly need be mentioned, that if more precise determinations of the intensity of sound vibrations are really to be obtained according to the method presented, the sounding-rod cannot be put into vibration by means of a clapper stroke, because the intensity of the vibrations elicited in this way decrease very quickly and almost entirely disappear; but they must be maintained in a state of constant vibration for a longer time by means of a continually adjusted intervention.

It can safely be presumed, that the electrical vibrations which are actually demonstrated, take place under the conditions in which we made our observations; hence it was only a question of testing the method by which such vibrations are made *observable*. After this method has been found to be proven, however, one can further build upon it, and it is certain that using this method will lead to the discovery of electrical vibrations under previously unthought-of conditions. To illustrate the manifoldness of these phenomena, the following experiment may be cited here. If a strong galvanic current is introduced close to a vibrating string, which forms a component of a wire circuit running back into itself, then as a result of that vibration, alternating positive and negative currents are induced in the circuit, whose intensity can be measured with the dynamometer, similarly to the way it is induced by the vibrating magnetized rod.

³³ [N. H. W.] Wilhelm Weber's *Werke*, Vol. I, page 367.

On various constructions of the dynamometer.

There are essentially *three* different constructions which can be given to the dynamometer, all of which are suited to exact measurements, and provide special advantages under differing conditions. In addition to the *first* construction, which has been applied up to now, a *second* presents itself almost automatically to begin with, since it is already frequently used, with regard to its most essential components, for observing the effects of the Earth's magnetism on a conductor. Specifically, for this purpose, a conductor wound in circles, together with the battery from which the current issued, was hung up on a thread or wire, like a magnet, and the rotational moment which the Earth exerts on this kind of closed circuit, was observed in the same way as on a suspended magnetic needle. In fact, this apparatus provides a rotatable conductor, whose oscillations and deviations can be observed with as great a refinement as those of our bifilar coil, and it is only necessary to surround the suspended battery with a fixed multiplier, through which a current likewise moves, in order to complete the dynamometer. Now, add to this the fact that the discovery of *constant* batteries by Daniell and Grove has paved the way for more refined applications of such an instrument, which was previously blocked by the variability of the currents. For this a small Grove's element is particularly suited, which, considering its small dimensions and low weight, provides a fairly strong and constant current. If mirror, telescope, and scale are added, the most refined observations can be carried out with this instrument. Figure 14 depicts such an instrument, as used by me for this purpose. *A* is the wire wound around in a ring, whose ends are connected by means of brass couplings *ab* and *a'b'* to the platinum and zinc poles of a small Grove's element *B* from the instrument-maker Kleinert in Berlin. This element rests on a wooden stand, whose upper part is equipped with a torsion ring *C*, to which the suspension filaments are fastened at *D*.

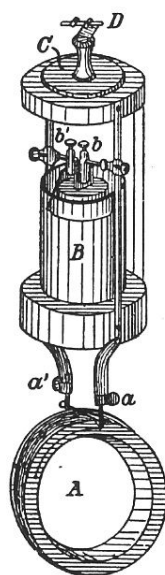

Fig. 14.

However suitable this construction of the dynamometer may be for a few special purposes, nonetheless it is far from able to replace the first construction, because it lacks *two* properties which the dynamometer with the *bifilar coil* possesses, and which are based on the fact that the current going through the bifilar coil can be further conducted, both through the fixed coil serving as multiplier, and through any other conductor as well. The *first* property consists in the fact that this

dynamometer can be used together with a *galvanometer*, by means of which an independent measurement of the intensity of the current in the bifilar coil can be obtained, which is not the case with the other instrument, because there the current from the suspended battery can not be drawn off through the multiplier of a *galvanometer*. However, the simultaneous observations on the *galvanometer* and *dynamometer* permit us to reduce the electrodynamic effects to the *same current intensity*, as repeatedly occurred in the previous undertakings. The lack of this property is not completely overcome by the use of constant batteries, because the current intensity even in such batteries is still always subject to considerable variations, which can in no way be disregarded in the course of more precise determinations.

The *second* property consists in the fact that, by letting the currents to be investigated with the *dynamometer* pass through *both* coils, the fixed coil as well as the rotatable one, one can determine the *square of the current intensity*, which is independent of the *direction* of the current. On this was based the peculiar characteristic of the instrument, which made it possible, in association with the electromagnetic galvanometer, to provide the elements necessary for knowledge of *momentary* currents. See Section 13 above. The other instrument whose rotatable coil formed a suspended, self-contained battery, also lacked this property; for here the different currents to be *investigated* can simply be brought through the conducting wire of the *fixed* coil, while the current in the *rotatable* coil remains unchanged, whereupon the effect of the current intensity, as with an electromagnetic galvanometer, is proportional to the current intensity itself, and consequently the instrument is capable of simply serving the role of an electromagnetic galvanometer, but not of supplementing it.

I now proceed to the *third* construction of the dynamometer, which, in that it shares the most essential properties of the first, is suited to give to electrodynamic measurements a still greater expansion, especially in cases where the *first* fails us because of the necessary fineness of the suspension wires through which the current is conducted.

This third construction is based on the same principle, which I have developed in the *Commentat. Soc. Reg. Sc. Gottingensis recentiores*, Vol. VIII,³⁴ for the purpose of describing a perfectly rotatable, friction-free *balance scale*, namely, on the principle of compensation between *gravity* and *elasticity*. There I hung the horizontal balance beam on two elastic vertical springs. These springs bent, of course, when the balance beam was turned, and thus, the more the beam was turned, the more they sought by means of their *elastic force* to *inhibit* the rotation; but if the rotation of the balance beam took place around an axis, which lay lower than its center of gravity, then, when the balance beam was rotated, the more the balance beam was rotated, the more the *force of gravity* sought to *accelerate* the rotation, and it turned out that, in this construction, the *inhibiting* influence of *elasticity* and the *accelerating* influence of *gravity* balanced each other, and consequently the beam remained firmly in balance not merely in a horizontal position, but also in an inclined position, and, without becoming hampered by friction, was able to switch from one of these positions to the other at the slightest impulsion.

I now used this kind of *compensated* balance beam for the dynamometer, and thereby replaced the rotatable coil, by making the same use of the two suspension springs to feed in and draw off the current, as I make of the two suspension wires. These springs are especially preferable to those fine wires, when it is a question of high-intensity currents, which should not be conducted through fine wires. It is sufficient to put the current through the strongest and shortest possible circuit; then the balance beam, through which this current is to pass, consists of a moderately long bar, held up by one of those two springs, to which bar, however, a mirror for more refined observation is attached. Finally, the *fixed* coil is replaced for the same reason with another moderately long *fixed* bar, by means of which the galvanic current is likewise conducted, and

³⁴ [N. H. W.] Wilhelm Weber's *Werke*, Vol. I, page 497.

which then acts on that *rotatable* bar, and deflects it, like a balance scale. The sensitivity of this instrument primarily depends on the two bars (the fixed one and the rotatable one) being placed parallel to each other at a slight distance apart. I have designed this instrument above all to give a greater range to electrodynamic experiments with *static* electricity, by rendering dispensable the special conditions which were necessary to achieve a truly reliable discharge in a Leyden jar through the many windings of the two coils of the *first* dynamometer. As yet, this latter instrument has not been perfected to the degree necessary for such a series of experiments.

Before I conclude this Section on the construction of the dynamometer, I wish to add another remark about its transformation into a *magnetic galvanometer*. I have already mentioned, that the wholly self-contained, *suspended* battery used for the *second* construction described above, was used earlier in *electromagnetic* experiments, specifically in order to observe the influence of Earth magnetism on a current conductor. With this self-contained suspended battery, if one were able to fully rely on the constancy of its current, all experiments on, and measurements of, Earth magnetism could be carried out exactly as with the magnetometer, and to that extent it would warrant the name of a *galvanic magnetometer*. Our first dynamometer, on the other hand, could be used as a *magnetic galvanometer*, which offers great advantages, even in comparison with a magnetometer equipped with a multiplier, if it is a question of *absolute*, not merely relative, determination of current intensity. The current conductor is in a fixed position with respect to the magnetometer equipped with a multiplier, and the magnet is rotatable; however, there is no essential influence on the effect, when one reverses this relationship and fixes the magnet, while the conductor is rotatable. The coil of our dynamometer, suspended by two wires, can now serve as the rotatable conductor, and the Earth itself can be used as the fixed magnet (which substitutes here for the fixed coil). However, if the Earth is now to actually perform this role, the bifilar coil must be oriented in a different way, namely, instead of being oriented like a *declination magnetometer*, as it was earlier, so that its axis is parallel to the magnetic meridian, it must be oriented, like the *intensity magnetometer*, so that its axis is perpendicular to the magnetic meridian. It can then be called a *magnetic bifilar galvanometer*. This simple instrument then presents great advantages for the *absolute* determination of current intensity, precisely because the position and distance apart of the individual components of the conducting wire compared with the individual components of the magnets no longer need be taken into account, because of the great distance at which the Earth magnetism acts, and hence, what is required for the purpose of this absolute determination of current intensity, in addition to the knowledge of the Earth magnetism, the deflection, the period of oscillation, and the inertial moment, in terms of absolute measure, is only the knowledge of one single element, namely, knowledge of the *area* surrounded by the wire, as I have already discussed in the "Resultaten aus den Beobachtungen des Magnetischen Vereins im Jahre 1840," page 93,³⁵ where I have communicated several such determinations of intensity according to absolute measure, which were made with this instrument.

Hitherto, the investigation primarily had the purpose of leading to *experimental* paths to determinations of measure for electrodynamic forces, and to expressing those forces according to the *absolute* measure, reduced to measure of space, time, and mass. This was the motivation for the construction given to the instruments, which, as in the case of Gauss's magnetometer, lays claim to a more solid arrangement and a greater scope than is called for by other physical apparatus, in which the scale of measurement is directly mounted on the instrument to be observed. Given the appropriate construction, it was possible to carry out larger individual series of experiments with precision; this construction, however, is not so easily altered again and adjusted to different kinds of purposes. In this connection I must acknowledge, as an especially favorable circumstance, that the spaciousness of the Leipzig Physics Institute was on the whole advantageous for this

³⁵ [N. H. W.] Wilhelm Weber's *Werke*, Vol. III, page 15.

construction; nevertheless, as mentioned several times, I had to confine myself for the present to preliminary experimental tests, because not all the constructions could be adequately manufactured in the same way. In consideration of these external constraints, present elsewhere still more than here, and because many experimenters are less accustomed to make observations with such instruments, I commissioned the local instrument-maker Mr. Leyser to complete smaller portable instruments for easier and more convenient manual use, without catoptric equipment, in the usual simple manner with pointer and subdivided circular scale, which suffice for conducting most experiments and for ordinary measurements. I call these smaller instruments to the attention of those who wish to engage in similar experiments, under conditions which do not permit the use of the instruments described.

*On the Connection between Electrostatic and Electrodynamical Phenomena with Application to
Electrodynamical Measurements.*

18.

Since the fundamental law of electrodynamics put forward by Ampère is found to be fully confirmed by precise measurements, the *foundations of electrodynamics* could perhaps be considered as definitively established. This would be the case, if all further research consisted of nothing but developing the applications and results which can be based on that law. For, granted that we could inquire into the *connection*, which exists between the fundamental laws of *electrodynamics* and *electrostatics*, yet, however interesting it may be, and however important for a more precise acquaintance with the *nature of bodies*, to have investigated this connection, nothing further would have been yielded for the explanation of *electrodynamical phenomena*, if these phenomena have really found their complete explanation in Ampère's law. In short, essential progress for electrodynamics itself would not be achieved by reducing its fundamentals to the fundamentals of electrostatics, however important and interesting such a reduction might be in other respects.

This view of the conclusions which the fundamentals of electrodynamics has reached through Ampère's basic law and its confirmation, essentially presupposes, however, that *all* electrodynamical phenomena are actually explained by that law. If this were not the case, if there existed any class of electrodynamical phenomena, which it does not explain, then that law would have to be considered merely as a provisional law, to be replaced in future by a truly universally valid, definitive law applicable to all electrodynamical phenomena. And in that case it could well occur, that this definitive law would be arrived at, by first seeking to reduce Ampère's law to a more general one, encompassing electrostatics. Namely, it would be possible that, under different conditions, the law of the remaining electrodynamical phenomena, which could not be directly traced to Ampère's law, would emerge out of the same sources from which both the electrostatic law and Ampère's law were derived, and that the foundation of electrodynamics in its greatest generality, would then be represented, not in isolation per se, but solely as dependent on the most general law of electricity, subsuming the foundation of electrostatics.

Now, in fact, there does exist such a class of electrodynamical phenomena, which, as we assume throughout this Treatise, depend on the reciprocal actions which electrical charges exert on each other *at a distance*, and which are not included in Ampère's law and cannot be explained by it, namely, the phenomena of *Volta-induction* discovered by Faraday, i.e., the *generation of a current* in a conducting wire through the influence of a current to which it is brought near; or the *generation of a current* in a conducting wire, when the intensity of the current in another nearby conducting wire increases or decreases.

Ampère's law leaves nothing to be desired, when it deals with the reciprocal actions of conducting wires, whose currents possess a *constant intensity*, and which are *fixed in their positions* with respect to one another; as soon as changes in the intensity of the current take place, however, or the conducting wires are moved with respect to one another, Ampère's law gives no complete and sufficient account; namely, in that case, it merely makes known the actions which take place on the *ponderable* wire element, but not the actions which take place on the *imponderable* electricity contained therein. Therefore, from this it follows, that this law holds only as a particular law, and can be only provisionally taken as a fundamental law; it still requires a definitive law with truly general validity, applicable to all electrodynamic phenomena, to replace it.

We are now in a position, to also predetermine in part the phenomena of *Volta-induction*; however, this determination is based, not on Ampère's law, but on the law of magnetic induction, which can be directly derived from experience, and which up to now has had no intrinsic connection with Ampère's law. And that predetermination of Volta-induction is in fact able to proceed, not through a strict deduction, but according to a mere analogy. Since such an analogy can indeed give an excellent guideline for scientific investigations, but as such must be deemed insufficient for a theoretical explanation of phenomena, it follows that the phenomena of Volta-induction are still altogether lacking theoretical explanation, and in particular have not received such explanation from Ampère's law. In addition, that predetermination of the phenomena of Volta-induction merely extends to those cases, where the inductive operation of a current, by analogy with its electrodynamic operation, can be replaced by the operation of a magnet. This, however, presupposes *closed currents* whose form is invariable. We can, however, claim, with the same justification as Ampère did for his law with respect to the reciprocal action of constant current elements, that the law of Volta-induction holds true for all cases, in that it gives a general determination for the reciprocal action of any two smallest elements, out of which all measurable effects are composed and can be calculated.

Thus, if we take up the connection between the *electrostatic* and *electrodynamic* phenomena, we need not simply be led by its general scientific interest to delve into the existing relations between the various branches of physics, but over and above this, we can set ourselves a more closely defined goal, which has to do with the *measurement of Volta-induction by means of a more general law of pure electrical theory*. These measurements of Volta-induction then belong to the *electrodynamic measurements* which form the main topic of this Treatise, and which, when they are complete, must also include the phenomena of *Volta-induction*. It is self-evident, however, that establishing such measurements is most profoundly connected with establishing the *laws*, to which the phenomena in question are subject, so that the one can not be separated from the other.

19.

In order to obtain for this investigation the most reliable possible guideline based on experience, the foundation will be *three special facts*, which are in part based indirectly on observation, in part contained directly in Ampère's law, which is confirmed by all measurements.

The *first fact* is, that two current elements lying in a straight line which coincides with their direction, *repel* or *attract* each other, according to whether the electricity flows through them in the *same* or *opposite* way.

The *second fact* is, that two parallel current elements, which form right angles with a line connecting them, *attract* or *repel* each other, according to whether the electricity flows through them in the *same* or *opposite* way.

The *third fact* is, that a current element, which lies together with a wire element in a straight line coinciding with the directions of both elements, induces a *like-* or *opposite-directed* current in the wire element, according to whether the intensity of its own current *decreases* or *increases*.

These three facts are, of course, not directly given through experience, because the effect of one *element* on another can not be directly observed; yet they are so closely connected with directly observed facts, that they have almost the same validity as the latter. The first two facts were already comprehended under Ampère's law; the third was added by Faraday's discovery.

The three adduced facts are considered as *electrical*, viz., we consider the indicated forces as *actions of electrical masses on each other*. The *electrical law* of this reciprocal action is still unknown, however; for, even if the first two facts are comprehended under Ampère's law, nevertheless, even apart from the third fact, which is not comprehended by it, Ampère's law is itself, in the strict sense, *no electrical law*, because it identifies *no electrical force*, which an electrical mass exerts on the other. Ampère's law merely provides a way to identify a force acting on the *ponderable mass of the conductor*. Ampère did not deal with the *electrical forces* which the *electrical fluids* flowing through the conductor exert on one another, though he repeatedly expressed the hope that it would be possible to explain the reciprocal effect of the *ponderable conductors* identified by his law, in terms of the reciprocal actions of the *electric fluids* contained in them.

If we now direct our attention to the *electrical fluids* in the two current elements themselves, we have in them like amounts of positive and negative electricity, which, in each element, are in motion in an opposing fashion. This simultaneous opposite motion of positive and negative electricity, as we are accustomed to assume it in all parts of a linear conducting wire, admittedly can not exist in reality, yet can be viewed for our purposes as an *ideal* motion, which, in the cases we are considering, where it is simply a matter of actions *at a distance*, represents the actually occurring motions in relation to all the actions to be taken into account, and thereby has the advantage, of subjecting itself better to calculation. The actually occurring lateral motion through which the particles encountering each other in the conducting wire (which latter forms *no mathematical line*) *avoid each other*, must be considered as without influence on the actions *at a distance*, hence it seems permissible for our purpose, to adhere to the foregoing simple view of the matter (see Section 31).

We have, then, in the *two* current elements we are considering, *four reciprocal actions* of electrical masses to consider, *two repulsive*, between the two positive and between the two negative masses in the current element, and *two attractive*, between the positive mass in the first and the negative mass in the second, and between the negative mass in the first and the positive mass in the second.

Every two *repulsive* forces would have to be *equal* to these two *attractive* forces, if the recognized laws of *electrostatics* had an *unconditional application to our case*, because the like, repulsive masses are equal to the unlike, attractive masses, and act on one another at the same distance. Whether those recognized *electrostatic* laws, however, find an *unconditional application* to our case, can not be decided a priori, because these laws chiefly refer only to such electrical masses, which are situated in *equilibrium* and at *rest* with respect to one another, while our electrical masses are in motion with respect to one another. Consequently, only *experience* can decide, whether that electrostatic law permits such an *enlarged application* to our case as well.

The two first *facts* adduced above refer, of course, chiefly to forces, which act on the *ponderable current carriers*; we can, however, consider these forces as the *resultants* of those forces, which act on the *electrical masses* contained in the ponderable carrier. Strictly speaking, that way of considering these forces is, to be sure, only permissible, when these electrical masses are bound to their common ponderable carrier in such a way, that they cannot be put in motion without it, and because this is not the case in the galvanic circuit, but on the contrary, the electrical masses are also in motion when their carrier is at rest, Ampère, as is stated in the introduction on

page 3,³⁶ particularly called attention to this circumstance, with the consideration that the force acting on the ponderable carrier could thereby be essentially modified. Although, however, the electrical masses are susceptible of being displaced in the direction of the conducting wire, they are in no way *freely moveable* in this direction; otherwise they would have to *persist* in the motion once it were transmitted to them in this direction, without a new external impetus (that is, without ongoing *electromotive force*), which is not the case. For no galvanic current persists *of itself*, even with a persistent closure of the circuit. Rather, its intensity at any moment corresponds only to the existing *electromotive force*, as determined by Ohm's law; thus it stops by itself, as soon as this force disappears. From this it follows, that not simply those forces, which act on the electrical masses in such directions (perpendicular to the conducting wire) that the masses can only be moved in tandem with the ponderable carrier, have to be transmitted to the latter, but that this very fact also holds true even of such forces, which act in the direction of the conducting wire and which move the electrical masses in the carrier, only with the difference, that the latter transmission requires an interval of time, although a very short one, which is not the case for the former. The *direct* action of the forces parallel to the conducting wire consists, to be sure, simply of a motion of the electrical masses in this direction; the effect of this motion is, however, a *resistance* in the ponderable carrier, by means of which, in an immeasurably short time, it is neutralized once more. Through this *resistance*, during the time interval in which this motion is neutralized, all forces, which had previously induced this motion, are *indirectly* transmitted to the ponderable bodies which exercise the resistance. Finally, since we are dealing with the effects of forces, which have the capacity to communicate a *measurable* velocity to the *ponderable* carrier itself, then on the other hand, those effects of forces, which only momentarily disturb the *imponderable* masses a little, can be disregarded with the same justification with which we disregard the *mass of the electricity* compared with the mass of its ponderable carrier. From this, however, it follows, that the force acting on the *current carrier* acts, as stated above, as the *resultant* of all forces acting on the *electrical masses* contained in the current carrier.

This presupposes, as shown by the *first two facts stated above*, that the *resultant* of those four reciprocal actions of the electrical masses contained in the two current elements under consideration, which, according to the *electrostatic* laws, ought to be zero, *departs* more from zero, the greater the *velocity*, with which the electrical masses flow through both current elements, that is, the greater the current intensities.

From this it follows, therefore, that the *electrostatic* laws have *no unconditional application* to electrical masses which are *in motion* with respect to one another, but on the contrary, they merely provide for the forces, which these masses reciprocally exert upon each other, a *limiting value*, to which the *true value* of these forces approximates more closely, the slighter the reciprocal motions of the masses, and from which, on the contrary, the *true value* is more divergent, the greater the reciprocal motions. To the values, which the *electrostatic* laws give for the force exerted by *two electrical masses* upon one another, must thus be added a *complement dependent upon their reciprocal motion*, if this force is to be correctly determined, not simply for the case of mutual rest and equilibrium, but universally, including any arbitrary *motion* of the two masses with respect to one another. This *complement*, which would confer upon the electrostatic laws a more general applicability than they presently possess, will now be sought.

The *first fact* stated above further shows, not simply that the sum of the repulsive forces of like electrical masses in the current elements under consideration *diverges* from the sum of the attractive forces of unlike masses, but also shows, when the first sum is *greater* and when it is *smaller* than the latter, and all determinations resulting therefrom can be unified in the simple statement,

³⁶ [N. E.] Page 29 of Weber's *Werke*, Vol. 3.

that the electrical masses, which have an opposite motion, act upon one another more weakly, than those which have a like motion.

For, 1) if the direction of the current is *the same* in the two elements, then *repulsion* occurs, consequently the *attractive force of the unlike masses* must be *weaker* than the repulsive forces of the like masses. In this case, however, it is the unlike masses, which are in *opposite motion*. If, however, 2) the direction of the current in the two elements is *opposite*, then *attraction* occurs; consequently the *repulsive forces of the like masses* must be *weaker* than the attractive forces of the unlike masses. In this case, however, it is the like masses, which are put into *opposite motion*. In both cases it is thus the masses *in opposite motion*, which act *more weakly* upon one another, confirming the statement above.

The *first fact*, to which the statement above was referred, further permits the following, more precise, determination to be added,

that two electrical masses (repulsive or attractive, according to whether they are like or unlike) act more weakly upon one another, the greater the square of their relative velocity.

The *relative velocity* of two electrical masses can, if r denotes the distance between the two masses, be expressed as dr/dt , and is positive or negative, according to whether the two masses are withdrawing from or approaching one another; since, however, this difference between approach and withdrawal, or, in short, the difference of the sign for dr/dt , has no influence upon the magnitude of the force, it was necessary in the just-stated rule to introduce, instead of the relative velocity itself, its *square*.

If we denote by e and e' the positive electrical masses in both elements, and by u and u' their *absolute* velocities, which have a positive or negative value according to the direction of the current, then $-e$ and $-e'$ will be the negative masses, and $-u$ and $-u'$ their *absolute* velocities. In the cases subsumed by the *first fact*, where all electrical masses are in motion *in one and the same straight line*, the *relative* velocities, however, result from the *absolute* by means of simple subtraction, namely, for the *like* masses:

$$+e \text{ and } +e' \text{ the relative velocity } \frac{dr}{dt} = u - u',$$

$$-e \text{ and } -e' \text{ the relative velocity } \frac{dr}{dt} = -u + u';$$

for the *unlike* masses:

$$+e \text{ and } -e' \text{ the relative velocity } \frac{dr}{dt} = u + u',$$

$$-e \text{ and } +e' \text{ the relative velocity } \frac{dr}{dt} = -u - u'.$$

From this results, according to the foregoing principle of the reciprocal action of *like* (two positive, as well as two negative) masses, a diminution dependent upon³⁷

$$\frac{dr^2}{dt^2} = (u - u')^2$$

³⁷ [N. E.] The notation $\frac{dr^2}{dt^2}$ should be understood as $\left(\frac{dr}{dt}\right)^2$.

in comparison with the case considered in electrostatics, of rest and equilibrium; for the reciprocal action of *unlike* masses, on the contrary, a decrease dependent upon

$$\frac{dr^2}{dt^2} = (u + u')^2$$

The simplest form, which the law of this decrease can have, is that in which the value of the force for the case of rest and equilibrium is multiplied by the factor

$$\left(1 - a^2 \frac{dr^2}{dt^2}\right)$$

whereby the following expression would therefore serve for the *complete determination of the force*:

$$\frac{ee'}{r^2} \left(1 - a^2 \frac{dr^2}{dt^2}\right),$$

in which e and e' have positive or negative values, according to whether the electrical masses which they denote are part of the positive or negative fluids. a^2 is a constant.

For our case, when we try to make use of this simplest form, there result the following four reciprocal actions between the electrical masses in the two current elements:

1. between $+e$ and $+e'$ the force $+\frac{ee'}{r^2} \left(1 - a^2(u - u')^2\right)$,
2. between $-e$ and $-e'$ the force $+\frac{ee'}{r^2} \left(1 - a^2(u - u')^2\right)$,
3. between $+e$ and $-e'$ the force $-\frac{ee'}{r^2} \left(1 - a^2(u + u')^2\right)$,
4. between $-e$ and $+e'$ the force $-\frac{ee'}{r^2} \left(1 - a^2(u + u')^2\right)$.

The sum of the first two forces, that is, the sum of the *repulsions of like masses*, is thus

$$= +2 \frac{ee'}{r^2} \left(1 - a^2(u - u')^2\right);$$

the sum of the two latter forces, that is, the sum of the *attractions of unlike forces*, is

$$= -2 \frac{ee'}{r^2} \left(1 - a^2(u + u')^2\right).$$

These two sums are thus, apart from their signs (distinguishing repulsion and attraction), distinguished according to their magnitude. Their algebraic sum, which yields *the resultants* of all four reciprocal actions, and consequently the force, which is transmitted from the electrical masses to the *current carrier* itself, and on which Ampère's law is based, is accordingly

$$= +8 \frac{ee'}{r^2} a^2 \cdot uu',$$

i.e., it follows that this force, in complete agreement with Ampère's law, is directly proportional to the current intensity in both current elements, and inversely proportional to the square of the distance between the two current elements.

We further observe, that the foregoing expression is *positive*, and consequently denotes a *repulsion of the current-elements*, if u and u' both have either a positive or negative value, i.e, if the electricity flows through both current elements in the same way; and that if *only one of the two is positive, the other negative*, the foregoing expression becomes *negative*, which denotes an *attraction of current-elements*, if the electricity is flowing through them *oppositely*. All these results precisely correspond to the *first fact* stated above.

If we now proceed to the *second fact stated above*, it is clear that the supplement to the electrostatic law just provided will no longer suffice here, because for all cases included under this second fact, it yields the value of the relative velocity of the electrical masses

$$\frac{dr}{dt} = 0.$$

That is to say, if we follow two electrical particles in their paths, the result is that their relative distance decreases up to the moment in question, and from then on increases again, and therefore, at the moment in question itself, neither increase nor decrease in the distance takes place; consequently, for all these cases, the electrostatic law itself, would be brought into application in order to determine the four reciprocal actions of the electric masses in both current elements, without applying a supplement to the law, according to which the two current elements ought to have no effect at all upon one another, which is not the case.

It is easily proven, however, that for this *second* class of cases, where the value of the relative velocity dr/dt disappears, the value of the *relative acceleration* d^2r/dt^2 stands out all the more significantly, while for the *first* class, where the latter value d^2r/dt^2 disappears, the first dr/dt stood out all the more significantly.

Thus we assume, that the magnitude of the reciprocal action of electrical masses in motion, as determined by the electrostatic law, requires a supplement, which depends, however, not simply on the *square of the relative velocity* of both masses $= dr^2/dt^2$, but also on their *relative acceleration* $= d^2r/dt^2$; the simplest form, which the general law of reciprocal action of two electrical masses can have, is that in which the value of the force for the case of rest and equilibrium is multiplied by the factor

$$\left(1 - a^2 \frac{dr^2}{dt^2} + b \frac{d^2r}{dt^2}\right)$$

and in which, therefore, the following expression would serve for the complete determination of the force:

$$\frac{ee'}{r^2} \left(1 - a^2 \frac{dr^2}{dt^2} + b \frac{d^2r}{dt^2}\right),$$

in which e and e' have positive and negative values, accordingly as the electrical masses which they denote, are part of the positive or negative electrical fluid. a^2 is the same constant as before; b is another magnitude independent of velocity and acceleration, whose value and sign remain to be more closely determined.

If, as before, e and e' now denote the positive electrical masses in both current elements, u and u' their absolute velocities, $-e$ and $-e'$, the negative masses, and $-u$ and $-u'$ their *absolute* velocities, and R denotes the distance between the current elements, r the distance of the two *positive* electrical masses, then for the first moment $r = R$, but because the electrical masses are in motion, r soon changes, while R remains unchanged, and after the time-interval t has occurred, the following equation is yielded for determining the value of r , calculated from that moment on:

$$r^2 = R^2 + (u - u')^2 t^2,$$

consequently, because R , u and u' are constant,

$$rdr = (u - u')^2 t dt$$

and

$$rd^2r + dr^2 = (u - u')^2 dt^2,$$

which yields the values of the *relative velocity* and *relative acceleration* at the end of time-interval t , namely:

$$\frac{dr}{dt} = \frac{(u-u')^2}{r} t$$

$$\frac{d^2r}{dt^2} = \frac{(u-u')^2}{r} \left(1 - \frac{(u-u')^2}{r^2} t^2 \right).$$

If we apply these general determinations to the considered moment, for which $t = 0$, we will obtain the values for the *relative velocity and acceleration of both positive masses* to be introduced into our expression:

$$\frac{dr}{dt} = 0$$

$$\frac{d^2r}{dt^2} = \frac{(u-u')^2}{r},$$

consequently, for the first of the four reciprocal actions we obtain:

1. between $+e$ and $+e'$ the force $+\frac{ee'}{r^2} \left(1 + \frac{b}{r} (u-u')^2 \right)$.

It is self-evident, that the remaining reciprocal actions can be derived from this first one, through substitution of the corresponding masses and velocities; then we obtain

2. between $-e$ and $-e'$ the force $+\frac{ee'}{r^2} \left(1 + \frac{b}{r} (u-u')^2 \right)$,

3. between $+e$ and $-e'$ the force $-\frac{ee'}{r^2} \left(1 + \frac{b}{r} (u+u')^2 \right)$,

4. between $-e$ and $+e'$ the force $-\frac{ee'}{r^2} \left(1 + \frac{b}{r} (u+u')^2 \right)$.

The sum of the first two forces, that is, the sum of the *repulsions of like masses*, is thus

$$= +2 \frac{ee'}{r^2} \left(1 + \frac{b}{r} (u-u')^2 \right).$$

The sum of the last two forces, that is, the sum of the *attraction of unlike masses*, is, however,

$$= -2 \frac{ee'}{r^2} \left(1 + \frac{b}{r} (u+u')^2 \right).$$

These two sums are, therefore, apart from their signs (distinguishing repulsion and attraction), *distinguished* by their magnitude. Their algebraic sum, which yields *the resultant* of all four forces, consequently the force which is transmitted from the electrical masses to the *current carrier* itself, and on which Ampère's law is based, is accordingly

$$= -8 \frac{ee'}{r^2} \cdot \frac{b}{r} \cdot uu',$$

i.e., this force accordingly emerges in complete agreement with Ampère's law, directly proportional to the current intensity in both current elements, and inversely proportional to the square of the distance between the two current elements.

We further observe, that if b is positive, the above expression would be *negative*, and consequently would denote an *attraction of current elements*, if u and u' both have either a positive or a negative value, i.e., if electricity flows through both current elements in *the same way*; if, however, only one of the two is positive, the other negative, then the above expression will be *positive*, which denotes a *repulsion* of the current elements, if the electricity flows through them in an *opposite way*. All these results precisely correspond to the *second fact* stated above.

If, finally, we return to Ampère's formula itself, which includes both facts as special cases, according to which the repulsion of two current elements is the following:

$$\frac{ii'}{r^2} \left(\cos \varepsilon - \frac{3}{2} \cos \vartheta \cos \vartheta' \right) ds ds',$$

wherein the letters have the significance given on page 36,³⁸ then, for the cases included under the *first fact*,

$$\varepsilon = 0^\circ \text{ or } = 180^\circ,$$

according to whether ϑ and ϑ' both

$$= 0^\circ \text{ or } = 180^\circ,$$

or only *one* of the two

$$= 0^\circ, \text{ the other } = 180^\circ.$$

Consequently, the sought-for value for the force in the cases included under the *first fact* is, according to Ampère's law

$$= \mp \frac{1}{2} \cdot \frac{ii'}{r^2} ds ds'.$$

For the cases included under the *second fact*,

$$\varepsilon = 0^\circ \text{ or } 180^\circ,$$

according to whether ϑ and ϑ' both

$$= 90^\circ \text{ or } = 270^\circ,$$

or only *one* of the two

$$= 90^\circ, \text{ the other } = 270^\circ.$$

Consequently, the sought-for value for the force in the cases included under the *second fact* is, according to Ampère's law

$$= \pm \frac{ii'}{r^2} ds ds'.$$

According to Ampère's fundamental law, we also obtain (apart from signs) a value for the latter case double that of the first.

This also results from our own determinations, if we make

$$a^2 = \frac{1}{2} \frac{b}{r}$$

whereby the value and the sign of b are more closely determined, namely:

$$b = 2ra^2.$$

If we substitute this value of b in our general expression for the reciprocal action of two electrical masses, the resulting *repulsive force* is

$$= \frac{ee'}{r^2} \left(1 - a^2 \frac{dr^2}{dt^2} + 2a^2 \cdot r \frac{d^2r}{dt^2} \right).$$

The *third fact stated above* is ultimately based, not, like the two previous ones, on forces, which merely act on the *current carrier*, but rather on forces which act on the *electrical masses* themselves and move them in their carrier, seeking to separate unlike masses; that is, on *electromotive* forces, which are exerted by electrical masses in motion in a galvanic conductor on electricity at rest. These forces, however, are not only *not determined* by the *electrostatic* law, but also *not determined* by Ampère's *electrodynamical* law, because the *latter* relates merely to the forces transmitted to the current carrier, and the *former*, were it to be applicable, would yield the value of

³⁸ [N. E.] Page 70 of Weber's *Werke*, Vol. 3.

the electromotive force = 0. Thus these forces form an essentially *new class*, with which Faraday's *discovery* has first acquainted us.

If we consider once more simply the *electrical masses* in the current element as well as in the element without current, we again have in each one, equal masses of positive and negative electricity; specifically, at any time in the current element these two masses are in motion with equally great velocity in opposed directions, and these velocities increase or decrease simultaneously by equal amounts; in the element without current, on the other hand, both masses are still at rest and in equilibrium. Further, among these four masses, four reciprocal actions are now to be distinguished, namely, two repulsive and two attractive, the former between the *like* masses, the latter between the *unlike*.

Now, from the *fact*, that a current *is produced* in the element, in which previously there was no current, we must conclude, that *another force*, than the one acting on the *negative* mass, must be acting on the *positive* electrical mass in this element, in the direction of the latter, because the negative mass can only receive that *opposite* motion through such a *difference* in the forces acting upon it, of which motion the current which manifests itself essentially consists. We thus express the fact initially in this way,

that the sum of the two forces, which are exerted by the positive and negative electrical masses in the current element on the positive mass at rest in the element without current, in the direction of the latter, is different from the sum of those two forces, which those masses exert in the cited current element on the negative mass at rest in the element without current, in the direction of the latter; that, however, the difference of the two sums, that is, the electromotive force itself, is dependent on the change in velocity of the two electrical masses in the given current element, and increase or decrease and disappear with this change.

Thus we are led by this *third fact*, as well, to add to the electrical forces determined by the *electrostatic* law, a *supplement contingent upon their motion*, and the question is merely, whether this justifies exactly the same supplement, as that which was established on the basis of the first two facts. This *third fact* therefore yields a *criterion* for testing the results already obtained, and is especially suited to their rejection or their firmer substantiation.

If we now denote, as above, e and e' the positive electrical masses in both wire elements, u and 0 their *absolute* velocities, and R the distance between the wire elements, r the distance between the two positive electrical masses: then for the first moment of time, $r = R$, but because mass e distances itself from, or approaches, the mass at rest e' with variable velocity u , r soon changes, while R remains unchanged, and we have for the determination of the value of r , after time-interval t has occurred, and calculated from that moment forward,

$$r = R \pm \int_0^t u dt ,$$

where the *upper* sign is in effect, if mass e lies on the positive side of mass e' , and consequently is still further distanced from it with a positive velocity; conversely, if mass e lies on the negative side of mass e' , and consequently approaches it with a positive velocity, the lower sign is in effect.

By means of differentiation, we obtain:

$$dr = \pm u dt$$

$$d^2r = \pm du dt .$$

According to this, the values of *relative velocity* and *relative acceleration* of both masses at the end of time-interval t are thus:

$$\frac{dr}{dt} = \pm u$$

$$\frac{d^2r}{dt^2} = \pm \frac{du}{dt};$$

in which u and du are functions of t . If we now apply these general determinations to the considered moment under consideration, and denote the values which u and du assume if $t = 0$, as u_0 and du_0 , then, according to the general law of reciprocal action of two electrical masses, to which the *two first facts* led, we obtain as the first of four reciprocal actions:

1. between $+e$ and $+e'$ the force $+\frac{ee'}{r^2}\left(1 - a^2u_0^2 \pm 2a^2r\frac{du_0}{dt}\right)$.

It also becomes clear, that the remaining reciprocal actions can be derived from this first one, through substitution of the corresponding masses, velocities, and accelerations; we then obtain:

2. between $-e$ and $+e'$ the force $-\frac{ee'}{r^2}\left(1 - a^2u_0^2 \mp 2a^2r\frac{du_0}{dt}\right)$,

3. between $+e$ and $-e'$ the force $-\frac{ee'}{r^2}\left(1 - a^2u_0^2 \pm 2a^2r\frac{du_0}{dt}\right)$,

4. between $-e$ and $-e'$ the force $+\frac{ee'}{r^2}\left(1 - a^2u_0^2 \mp 2a^2r\frac{du_0}{dt}\right)$.

The sum of the two first forces, that is, the sum of the forces acting on the *positive mass $+e'$ in the element without current*, is therefore

$$= \pm 4 \frac{ee'}{r} a^2 \frac{du_0}{dt}.$$

The sum of the two latter forces, that is, the sum of the forces acting on the *negative mass $-e'$ in the element without current*, is, however,

$$= \mp 4 \frac{ee'}{r} a^2 \frac{du_0}{dt}.$$

These two sums are differentiated by their *opposing signs* (distinguishing repulsion and attraction). Their *difference* yields the *electromotive force*, which seeks to separate the positive and negative masses in the element without current,

$$= \pm 8 \frac{ee'}{r} a^2 \frac{du_0}{dt},$$

i.e., the *electromotive force* is directly proportional to the self-initiated change in the velocity of the current at the moment under consideration, and inversely proportional to the distance of the current element from the element without current.

Further, as for the double signs in our expression for the *electromotive force*, they can be eliminated, if we base them on the distance r and thus impute to it positive and negative values, calculating r from the locus of the mass at rest e' as the initial point, and specifically as a positive magnitude, when the mass e calculated from this initial point lies on the positive side (toward which the positive velocities are directed), and as a negative magnitude, when the mass e lies on the negative side from this initial point. If, for example, in Figure 15, A denotes the locus of the mass at rest e' , BAC the given line of direction, and the side on which C lies is established as the positive side, then r is positive, if mass e is at point C , negative, when mass e is at point B .



Fig. 15.

If, therefore, two like current elements are located at B and C , through which electricity is flowing *in the same way*, and the intensity of its current increases or decreases by the same amount, then these two current elements will exert opposite electrical forces on the electrical masses at rest at A , such that that mass, which is repulsed from C , is attracted by B , and vice versa; the force which seeks to separate the positive and negative masses at A , is thus *doubled* by means of the combined operation of the two current elements at B and C .

Finally, if r is positive, if, e.g., the current element is located at C , and if, further, u and du both have either negative or positive values, i.e., if the absolute current velocity at C increases, regardless of its direction, then the foregoing expression has a positive or negative value, according to whether u has a positive or negative value, i.e., therefore, under *increasing* current intensity, an *electromotive force* acts from C repulsively or attractively on the positive electrical mass at A , according to whether the current at C itself is directed forwards or backwards, and thus excites at A a current *opposite* to the one present at C , fully corresponding to the determinations contained in the *third fact* stated above.

From this it follows, that this *third fact* confirms the result derived from the first two, in that *the same complement* of the electrostatic law into a general law, which served to explain the first two facts, also suffices to explain the third.

20.

In the foregoing Section, following the guideline of experience, we have sought to add to the electrostatic formulation for the repulsive or attractive force, with which two like or unlike electrical masses act upon one another at a distance, in such a way, that the formulation is applicable, not simply when both masses are at rest with respect to one another, but also when they are in motion with respect to one another. We have tested and confirmed this expansion on particular facts, and in the following Section, will present this test with greater generality.

Assuming the correctness of the results which we achieved, a case would arise here, in which the force, with which two masses act upon one another, would depend, not simply upon *the magnitude of the masses and their distance* from one another, but also on their *relative velocity and relative acceleration*. The calculation of these forces will thus in many cases come up against greater mathematical difficulties, than the calculation of such forces which simply depend upon the magnitude of the masses and their distances. It should also be expected, if this dependency of the electrical forces, not simply on the magnitude of the electrical masses and their distances, but also on their relative velocities and accelerations, were firmly established, that this very dependency, even if to a lesser extent, would exist in other forces, according to more exact investigation.

Thereby a completely new element would be introduced into the dependency of forces on given physical relationships, and the domain of forces, whose determination would require taking this new element into account, would form a specific class, requiring a special investigation.

As, however, it must also appear highly desirable, for the purpose of simplifying and facilitating our investigations, that the domain of those forces which depend simply on the magnitude of the masses and their distances, be extended as widely as possible, then, *only experience* can decide whether other forces, which are also dependent on the mutual velocities and accelerations of the masses, must be assumed to be present, or not. This question cannot be decided

a priori, because formally, the assumption of such forces contains neither a contradiction, nor anything unclear or indeterminate.

The law of the dependence of forces upon given physical relationships is called the *fundamental law of physics*, and, in accordance with the goals of physics, it is not supposed to provide an *explanation* of the forces based on their true causes, but only a clearly demonstrated and useful general method for *quantitative* determination of forces, according to the fundamental metrics established in physics for space and time. Hence, from the standpoint of physics, one can not take offense at the fact that a force is made into a function of *a relationship dependent on time*, any more than one can take offense at the fact that it is made into a function of *distance*, because a relationship dependent on time is just as measurable a magnitude as a distance; therefore, in virtue of their nature, both are suited to more rigorous *quantitative* determination, even if it is not appropriate to seek in them the *inherent reason* for a force.

At most, accordingly, against the introduction of a time-dependent relationship in the general expression for a force, the *analogy with another fundamental law of physics*, e.g. with the law of gravitation, may be asserted, where this time-dependent relationship does not occur. Yet such an analogy can only be viewed as binding, when it offers ways and means to achieve the goal; where the analogy with known cases does not suffice, in the nature of the case new paths must be sought.

If, therefore, the introduction of such *time-dependent relationships* in the general expression for a force cannot be rejected in general, then all the less so, if those relationships are an essential part of the complete determination of the *existing condition* of masses acting upon one another, since in any case the force, which two masses exert upon one another, since it *does not always* remain the same, must be thought of subject to the *condition existing at the time*. Complete determination of the present condition of two masses, however, essentially involves, in addition to the determination of their *relative position* by means of their mutual distance r , the determination of their *relative movement* by means of their relative velocity dr/dt . For, according to the principle of inertia, one has no choice but to calculate the velocity of a body essentially in its present condition, because the reason for the inertia lies, according to that principle, in the body itself, and consequently the persistence in *different* motion must correspond to *different* internal conditions of the body, which, themselves inaccessible to our observation, can only be distinguished by means of their effects emerging over time.

21.

Transformation of Ampère's law.

What was proven in the foregoing Sections for a few special facts, is now to be proven more generally and more precisely for all facts contained under Ampère's law. Ampère's law determines the *total effect* which one current element exerts on the other, depending on the *distance* of the two elements from each other, on their two *current intensities*, and on the three *angles* which the directions of the current elements make with each other and with the straight lines connecting them. Now, if it is to be possible to reduce this *total effect*, thus determined, to *elementary electrical forces*, then *first* Ampère's formula must be able to be broken down into several parts, which correspond to the effects of *each pair of electrical masses* in both current elements, in particular to the effect of the positive mass of the one element on the positive mass of the other, of the negative mass of the one element on the negative mass of the other, of the positive mass of the former on the negative of the latter, and finally of the negative mass of the former on the positive of the latter. *Secondly*, each of these parts, as *elementary electrical force*, must be wholly dependent on such magnitudes, which exclusively appertain to the nature and the mutual relations of the two electrical

masses, to which the part refers, and be completely determined thereby, independently of other conditions. *Thirdly* and finally, all these *elementary electrical forces* would have to be susceptible of being brought under a *general law*. It is, however, not necessary, to make any sort of hypothesis in advance about this general law; rather, Ampère's law, under such a transformation, would have to lead directly to the statement of this general law and decide on the admissibility or inadmissibility of such a hypothesis posed in advance. At the outset, the following question is to be answered:

whether Ampère's formula permits a transformation, such that the current intensities contained therein, i and i' , and the angles ε , ϑ , and ϑ' , which the two current elements form with each other and with the straight line connecting the two elements, vanish from the formula, and instead of these, only such new magnitudes are introduced, which fully and exclusively refer to the electrical masses themselves and their mutual relations.

This transformation is now actually to be carried out here, and then it will be examined whether the expression for the electrodynamic force, transformed in this way, permits the requisite decomposition into four parts, corresponding to four partial effects, of which the total effect would be composed.

Ampère's formula for the repulsive force of two current elements is as follows:

$$-\frac{ii'}{r^2} \left(\cos \varepsilon - \frac{3}{2} \cos \vartheta \cos \vartheta' \right) \cdot ds ds',$$

in which the letters have the signification given in Section 8, page 36.³⁹

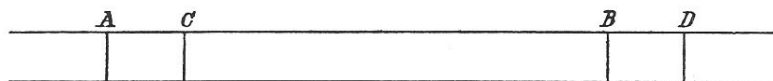

Fig. 16.

In Figure 16, AB is a segment of the one conducting wire of length = 1, and the quantity of the uniformly distributed positive electricity in it is denoted by e , so that eds is the mass of positive electricity which the current element contains, whose length = ds .

With the constant velocity u , which all positive electrical components possess in the conducting wire AB when a constant current passes through, in one second the one farthest forward traverses the path BD , the one farthest back the path AC , and the electrical mass e , which at the beginning of the second was uniformly distributed in the segment $AB = 1$, is located at the end of the second in segment $CD = 1$. Hence, during one second, all the electricity which, at the end of the second, is contained on the other side from B in the segment of the conducting wire $BD = u$, has passed through the cross-section of the conducting wire at B . This electricity, in conformity with the definition of current intensity given at the beginning of Section 2 (according to which it is proportional to the amount of electricity passing through a cross-section of the circuit in one second), can now be set = i/a , where a denotes a constant. There then results

$$\frac{i}{a} : e = u : 1,$$

consequently $i = ae u$. The value of a is different from that in Section 19.

³⁹ [N. E.] Page 70 of Weber's *Werke*, Vol. 3.

It likewise results that, if u' denotes the current velocity of the electricity in another conducting wire,

$$i' = ae'u'.$$

If one substitutes these values in Ampère's formula, the formula will be

$$-\frac{eds \cdot e'ds'}{r^2} a^2 uu' \left(\cos \varepsilon - \frac{3}{2} \cos \vartheta \cos \vartheta' \right),$$

where, therefore, the first factor $eds \cdot e'ds'/r^2$ denotes the product of two *electrical masses* acting on one another in the two current elements, divided by the square of their *distance*.

Further, Ampère has already shown on page 207 of his Treatise, that it would be the case that

$$\cos \vartheta = \frac{dr}{ds}, \quad \cos \vartheta' = -\frac{dr}{ds'}$$

and

$$\cos \varepsilon = -r \frac{d^2 r}{ds ds'} - \frac{dr}{ds} \frac{dr}{ds'}$$

If one substitutes these values, the Ampère formula takes the following form:

$$-\frac{eds \cdot e'ds'}{r^2} \cdot a^2 uu' \left(\frac{1}{2} \frac{dr}{ds} \frac{dr}{ds'} - r \frac{d^2 r}{ds ds'} \right).$$

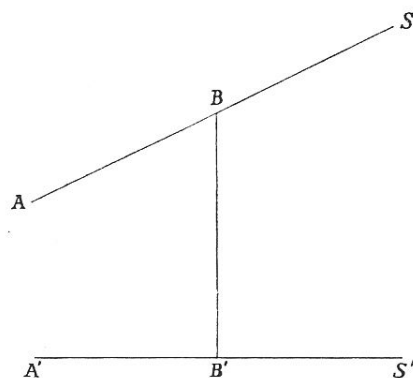

Fig.17.

Let the element ds of the conducting wire ABS be located at B in Figure 17; the initial point of the conducting wire would be put at A , consequently $AB = s$. Let the element ds' of the conducting wire $A'B'S'$ lie at B , A' be the initial point of this wire, $A'B' = s'$ and $BB' = r$. The last magnitude r , if the conducting wires ABS and $A'B'S'$ are given, is a function of s and s' , and the following expressions obtain for dr and $d^2 r$:

$$dr = \frac{dr}{ds} ds + \frac{dr}{ds'} ds'$$

$$d^2 r = \frac{d^2 r}{ds^2} ds^2 + 2 \frac{d^2 r}{ds ds'} ds ds' + \frac{d^2 r}{ds'^2} ds'^2.$$

If s and s' now denote the lengths of the conducting wires from their initial points to the current elements themselves which are under consideration, then s and s' have constant values for two given current elements. However, s and s' can also signify the length of the conducting wires from their initial points to the *electrical masses* just now existing in the current elements under

consideration, but flowing through them further. In this last signification, s and s' are variable with the time t , and then one has

$$\frac{dr}{dt} = \frac{dr}{ds} \cdot \frac{ds}{dt} + \frac{dr}{ds'} \cdot \frac{ds'}{dt},$$

$$\frac{d^2r}{dt^2} = \frac{d^2r}{ds^2} \cdot \frac{ds^2}{dt^2} + 2 \frac{d^2r}{dsds'} \cdot \frac{dsds'}{dt^2} + \frac{d^2r}{ds'^2} \cdot \frac{ds'^2}{dt^2}.$$

Here, in ds/dt , the velocity element of the electrical mass is divided by the time element in which it will pass through, i.e., the *velocity* of the electrical mass, and therefore $ds/dt = u$, when the *positive* mass is considered first. Likewise, then $ds'/dt = u'$. If these values are substituted, then

$$\frac{dr}{dt} = u \frac{dr}{ds} + u' \frac{dr}{ds'},$$

$$\frac{d^2r}{dt^2} = u^2 \frac{d^2r}{ds^2} + 2uu' \frac{d^2r}{dsds'} + u'^2 \frac{d^2r}{ds'^2}.$$

From the latter equation, and from the one derived from the first

$$\frac{dr^2}{dt^2} = u^2 \frac{dr^2}{ds^2} + 2uu' \frac{dr}{ds} \frac{dr}{ds'} + u'^2 \frac{d^2r}{ds'^2}$$

the following values obtain for $2uu' \frac{d^2r}{dsds'}$ and $2uu' \frac{drdr}{dsds'}$:

$$2uu' \frac{d^2r}{dsds'} = \frac{d^2r}{dt^2} - u^2 \frac{d^2r}{ds^2} - u'^2 \frac{d^2r}{ds'^2},$$

$$2uu' \frac{drdr}{dsds'} = \frac{dr^2}{dt^2} - u^2 \frac{dr^2}{ds^2} - u'^2 \frac{dr^2}{ds'^2},$$

from which it follows:

$$uu' \left(\frac{1}{2} \frac{drdr}{dsds'} - r \frac{d^2r}{dsds'} \right) = \left(\frac{1}{4} \frac{dr^2}{dt^2} - \frac{1}{2} r \frac{d^2r}{dt^2} \right) - \left(\frac{1}{4} \frac{dr^2}{ds^2} - \frac{1}{2} r \frac{d^2r}{ds^2} \right) u^2 - \left(\frac{1}{4} \frac{dr^2}{ds'^2} - \frac{1}{2} r \frac{d^2r}{ds'^2} \right) u'^2.$$

If these values are substituted, then Ampère's formula takes the following form:

$$-\frac{eds \cdot e' ds'}{r^2} a^2 \left\{ \left(\frac{1}{4} \frac{dr^2}{dt^2} - \frac{1}{2} r \frac{d^2r}{dt^2} \right) - \left(\frac{1}{4} \frac{dr^2}{ds^2} - \frac{1}{2} r \frac{d^2r}{ds^2} \right) u^2 - \left(\frac{1}{4} \frac{dr^2}{ds'^2} - \frac{1}{2} r \frac{d^2r}{ds'^2} \right) u'^2 \right\}.$$

In this transformation of Ampère's formula, there are first introduced merely the *positive electrical masses*, which move in their trajectories with the velocities u and u' . It is clear that one can also introduce the *negative* electrical masses instead of the positive ones. It then results, if this occurs for both current elements alike, that both of the masses introduced are therefore again of *the same kind*, but their velocities, in accordance with the determinations given for galvanic currents on page 85,⁴⁰ both maintain the opposite values, namely $-u$ and $-u'$, in turn in the same expression. Then if r_1 , ζ and ζ' denote for the *negative* masses the same thing that r , s , and s' denote for the *positive*, Ampère's formula would be obtained at first in the following form:

$$-\frac{eds \cdot e' ds'}{r_1^2} a^2 \left\{ \left(\frac{1}{4} \frac{dr_1^2}{dt^2} - \frac{1}{2} r_1 \frac{d^2r_1}{dt^2} \right) - \left(\frac{1}{4} \frac{dr_1^2}{d\zeta^2} - \frac{1}{2} r_1 \frac{d^2r_1}{d\zeta^2} \right) u^2 - \left(\frac{1}{4} \frac{dr_1^2}{d\zeta'^2} - \frac{1}{2} r_1 \frac{d^2r_1}{d\zeta'^2} \right) u'^2 \right\}.$$

For the moment under consideration, where those *positive* masses (to which r , s , and s' refer) and these *negative* masses (to which r_1 , ζ , and ζ' refer) go through the same current elements, however,

⁴⁰ [N. E.] Page 139 of Weber's *Werke*, Vol. 3.

$$r = r_1, \quad s = \zeta, \quad s' = \zeta'.$$

Further, it is also the case that

$$\frac{dr_1}{d\zeta} = \frac{dr}{ds}, \quad \frac{d^2r_1}{d\zeta^2} = \frac{d^2r}{ds^2}, \quad \frac{dr_1}{d\zeta'} = \frac{dr}{ds'}, \quad \frac{d^2r_1}{d\zeta'^2} = \frac{d^2r}{ds'^2},$$

because all these values are simply dependent upon the position of the current elements through which those *positive* and these *negative* masses flow, but independent of the motion of the masses in these current elements. Finally,

$$\frac{d\zeta}{dt} = -u = -\frac{ds}{dt}, \quad \frac{d\zeta'}{dt} = -u' = -\frac{ds'}{dt},$$

consequently,

$$\frac{dr_1}{dt} = \frac{dr_1}{d\zeta} \cdot \frac{d\zeta}{dt} + \frac{dr_1}{d\zeta'} \cdot \frac{d\zeta'}{dt} = -\left(\frac{dr}{ds} \cdot \frac{ds}{dt} + \frac{dr}{ds'} \cdot \frac{ds'}{dt}\right) = -\frac{dr}{dt},$$

which yields

$$\frac{dr_1}{dt^2} = \frac{dr^2}{dt^2}$$

Likewise one finds

$$\frac{d^2r_1}{dt^2} = \frac{d^2r}{dt^2}.$$

By substitution of these values, the latter expression changes into the former.

It is a different case when a *positive* and a *negative* mass are introduced, viz., with *unlike kinds* of masses. If one keeps the *positive* mass in the first current element, the *negative* in the second, and denotes their distance with r_2 , then Ampère's formula is obtained in the following form:

$$+ \frac{eds \cdot e' ds'}{r_2^2} \cdot a^2 \left\{ \left(\frac{1}{4} \frac{dr_2^2}{dt^2} - \frac{1}{2} r_2 \frac{d^2r_2}{dt^2} \right) - \left(\frac{1}{4} \frac{dr_2^2}{ds^2} - \frac{1}{2} r_2 \frac{d^2r_2}{ds^2} \right) u^2 - \left(\frac{1}{4} \frac{dr_2^2}{d\zeta'^2} - \frac{1}{2} r_2 \frac{d^2r_2}{d\zeta'^2} \right) u'^2 \right\}.$$

On the other hand, if one keeps the *negative* mass in the first current element, the *positive* in the second, and denotes their distance with r_3 , then Ampère's formula is obtained in the following form:

$$+ \frac{eds \cdot e' ds'}{r_3^2} \cdot a^2 \left\{ \left(\frac{1}{4} \frac{dr_3^2}{dt^2} - \frac{1}{2} r_3 \frac{d^2r_3}{dt^2} \right) - \left(\frac{1}{4} \frac{dr_3^2}{d\zeta^2} - \frac{1}{2} r_3 \frac{d^2r_3}{d\zeta^2} \right) u^2 - \left(\frac{1}{4} \frac{dr_3^2}{ds'^2} - \frac{1}{2} r_3 \frac{d^2r_3}{ds'^2} \right) u'^2 \right\}.$$

Here too, if it is now the case that $r_2 = r_3 = r$, then

$$\begin{aligned} \frac{dr_2}{ds} = \frac{dr_3}{d\zeta} = \frac{dr}{ds}, & \quad \frac{d^2r_2}{ds^2} = \frac{d^2r_3}{d\zeta^2} = \frac{d^2r}{ds^2}, \\ \frac{dr_2}{d\zeta'} = \frac{dr_3}{ds'} = \frac{dr}{ds'}, & \quad \frac{d^2r_2}{ds'^2} = \frac{d^2r_3}{ds'^2} = \frac{d^2r}{ds'^2}, \end{aligned}$$

however, it results that

$$\begin{aligned} \frac{dr_2}{dt} &= \frac{dr_2}{ds} \cdot \frac{ds}{dt} + \frac{dr_2}{d\zeta'} \cdot \frac{d\zeta'}{dt} = + \frac{dr}{ds} \cdot \frac{ds}{dt} - \frac{dr}{ds'} \cdot \frac{ds'}{dt}, \\ \frac{dr_3}{dt} &= \frac{dr_3}{d\zeta} \cdot \frac{d\zeta}{dt} + \frac{dr_3}{ds'} \cdot \frac{ds'}{dt} = - \frac{dr}{ds} \cdot \frac{ds}{dt} + \frac{dr}{ds'} \cdot \frac{ds'}{dt} = - \frac{dr_2}{dt}, \end{aligned}$$

consequently $dr_2^2/dt^2 = dr_3^2/dt^2$ is different from dr^2/dt^2 . Likewise, one finds $d^2r_2/dt^2 = d^2r_3/dt^2$ to be different from d^2r/dt^2 . By substituting these values, in both cases where one introduces masses of a *different kind*, one obtains the same expression for Ampère's formula, namely:

$$+ eds \cdot e' ds' a^2 \left\{ \frac{1}{r_2^2} \left(\frac{1}{4} \frac{dr_2^2}{dt^2} - \frac{1}{2} r_2 \frac{d^2 r_2}{dt^2} \right) - \left(\frac{1}{4} \frac{dr^2}{ds^2} - \frac{1}{2} r \frac{d^2 r}{ds^2} \right) \frac{u^2}{r^2} - \left(\frac{1}{4} \frac{dr^2}{ds'^2} - \frac{1}{2} r \frac{d^2 r}{ds'^2} \right) \frac{u'^2}{r^2} \right\}.$$

Now, since both expressions, the earlier one, which was obtained by introducing masses of *the same kind*, as well as the later one, obtained by introducing masses of *a different kind*, represent the force with which two current elements act upon each other, are both identical with Ampère's formula, yet a third will be derived from them for the same force, likewise identical with Ampère's formula, if one takes their half-sums, that is,

$$- \frac{a^2 eds \cdot e' ds'}{2 r^2} \left(\frac{1}{4} \frac{dr^2}{dt^2} - \frac{1}{2} r \frac{d^2 r}{dt^2} \right) + \frac{a^2}{2} \cdot \frac{eds \cdot e' ds'}{r_2^2} \left(\frac{1}{4} \frac{dr_2^2}{dt^2} - \frac{1}{2} r_2 \frac{d^2 r_2}{dt^2} \right).$$

This last expression, equivalent to Ampère's formula, is the sought-for *transformation*. For thereby the magnitudes $i, i', \varepsilon, \mathcal{G}$ and \mathcal{G}' are eliminated, and only such magnitudes introduced in their place which have to do with, partly the *same*, partly the *different kind of* electrical masses themselves and their mutual relations.

This *transformed* expression for Ampère's formula can now be represented as a sum of four parts, which can be considered as the *elementary electrical forces*, namely, in the following way:

$$\begin{aligned} & + \frac{eds \cdot e' ds'}{r^2} \left(1 - \frac{a^2}{16} \frac{dr^2}{dt^2} + \frac{a^2}{8} r \frac{d^2 r}{dt^2} \right), \text{ as effect of } + eds \text{ on } + e' ds'; \\ & + \frac{eds \cdot e' ds'}{r_1^2} \left(1 - \frac{a^2}{16} \frac{dr_1^2}{dt^2} + \frac{a^2}{8} r_1 \frac{d^2 r_1}{dt^2} \right), \text{ as effect of } - eds \text{ on } - e' ds'; \\ & - \frac{eds \cdot e' ds'}{r_2^2} \left(1 - \frac{a^2}{16} \frac{dr_2^2}{dt^2} + \frac{a^2}{8} r_2 \frac{d^2 r_2}{dt^2} \right) \text{ as effect of } + eds \text{ on } - e' ds'; \\ & - \frac{eds \cdot e' ds'}{r_3^2} \left(1 - \frac{a^2}{16} \frac{dr_3^2}{dt^2} + \frac{a^2}{8} r_3 \frac{d^2 r_3}{dt^2} \right) \text{ as effect of } - eds \text{ on } + e' ds'; \end{aligned}$$

Each of these four partial effects reduces itself, for the case of rest, where $dr/dt = dr_1/dt = dr_2/dt = dr_3/dt = 0$ and likewise $d^2r/dt^2 = d^2r_1/dt^2 = d^2r_2/dt^2 = d^2r_3/dt^2 = 0$, to the same values, as are defined for this case by the fundamental law of *electrostatics*; for these four forces are expressed in that case by the product of the masses acting upon each other, divided by the square of their distances. Accordingly as each product has a positive or negative value, the force acts to repel or attract.

If, as in electrostatics, the electrical masses are denoted simply by e and e' , and these masses themselves are given positive or negative values, according to whether they belong to the positive or negative fluid, then all those partial effects can be brought under the *general law*, in which the repulsive force of those masses is represented by

$$\frac{ee'}{r^2} \left(1 - \frac{a^2}{16} \frac{dr^2}{dt^2} + \frac{a^2}{8} r \frac{d^2 r}{dt^2} \right).$$

Therefore, from this analysis of Ampère's law, which is a more precise expression of a very extensive class of facts, there follows the same *fundamental electrical law*, which in the preceding

Sections was established merely by introducing particular facts, and this was demonstrated without hypothesis.

22.

Theory of two constant current elements.

Having attained the *fundamental electrical law* expressed in the previous Section, we can place it at the head of the theory of electricity, and from it synthetically derive a system of consequences, which is the ultimate purpose of such a law.

The consequences which can be derived from it for *static* electricity, are found in Poisson's classic Treatise in the *Mémoires de l'academie des sciences de l'institut de France*, for the year 1812. For the foregoing fundamental law is, for the case of statics, identical with that law which Poisson, in the cited location, placed at the head of electrostatics.

For *moving* electricity, first the *uniform* motion of the electricity of galvanic currents in conductors at rest is to be considered, to which Ampère's law relates. Now, since the above fundamental electrical law was developed analytically from Ampère's law, Ampère's law must in turn follow synthetically from this fundamental law. This derivation is actually to be given here.

In two current elements α and α' , which, with the straight line connecting them, lie in planes which make the angle ω with one another, four *electrical masses* are given, namely, one *positive* and one *equally large negative* in each current element.

For element α , $+\alpha e$ would denote the *positive* mass, which moves with constant velocity $+u$ in the direction of element α , which forms the angle \mathcal{G} with the straight line r directed from the first element to the second; for the same element, $-\alpha e$ would denote the *negative* mass, which moves in the same direction with the constant velocity $-u$, viz., backwards.

The letters with primes $\pm\alpha'e'$, $\pm u'$ and \mathcal{G}' denote the same thing for the other element α' , as the letters without primes denote for the first element α .

Among these four masses, the following four effects are to be considered:

- from $+\alpha e$ to $+\alpha'e'$,
- from $-\alpha e$ to $-\alpha'e'$,
- from $+\alpha e$ to $-\alpha'e'$,
- from $-\alpha e$ to $+\alpha'e'$.

The four distances of these masses acting upon each other at a distance are equal at the moment under consideration, when all these masses are located in the two given elements α and α' , to the given distance of these two elements r . These four distances, because they do not always remain equal, on account of the differing motions of the masses, are denoted by r_1 , r_2 , r_3 , r_4 , and therefore, at the moment under consideration

$$r_1 = r_2 = r_3 = r_4 = r.$$

The application of the fundamental law given at the end of the previous Section then directly yields the values for these four partial effects, in succession,

$$\begin{aligned} & + \frac{\alpha e \cdot \alpha' e'}{r_1^2} \left(1 - \frac{a^2}{16} \frac{dr_1^2}{dt^2} + \frac{a^2}{8} r_1 \frac{d^2 r_1}{dt^2} \right), \\ & + \frac{\alpha e \cdot \alpha' e'}{r_2^2} \left(1 - \frac{a^2}{16} \frac{dr_2^2}{dt^2} + \frac{a^2}{8} r_2 \frac{d^2 r_2}{dt^2} \right), \\ & - \frac{\alpha e \cdot \alpha' e'}{r_3^2} \left(1 - \frac{a^2}{16} \frac{dr_3^2}{dt^2} + \frac{a^2}{8} r_3 \frac{d^2 r_3}{dt^2} \right), \end{aligned}$$

$$-\frac{\alpha e \cdot \alpha' e'}{r_4^2} \left(1 - \frac{a^2}{16} \frac{dr_4^2}{dt^2} + \frac{a^2}{8} r_4 \frac{d^2 r_4}{dt^2} \right).$$

These four forces are transferred from the electrical masses $+\alpha' e'$ and $-\alpha' e'$, on which they directly act, according to Section 19, page 84,⁴¹ to the ponderable mass of the element α' , and combine therein into a resultant, which is equal to the algebraic sum of those forces. This sum is, with respect to the already mentioned equality of the distances,

$$-\frac{a^2}{16} \cdot \frac{\alpha e \cdot \alpha' e'}{r^2} \left\{ \left(\frac{dr_1^2}{dt^2} + \frac{dr_2^2}{dt^2} - \frac{dr_3^2}{dt^2} - \frac{dr_4^2}{dt^2} \right) - 2r \left(\frac{d^2 r_1}{dt^2} + \frac{d^2 r_2}{dt^2} - \frac{d^2 r_3}{dt^2} - \frac{d^2 r_4}{dt^2} \right) \right\}.$$

If the mass $+\alpha e$ now progresses in its path in the time element dt with velocity $+u$ by the element of displacement $+u dt$, which path forms the angle \mathcal{G} with the straight line r_1 , while the mass $+\alpha' e'$ progresses in its path in the same time element dt with the velocity $+u'$ by the element of displacement $+u' dt$, which path forms the angle \mathcal{G}' with the extended straight line r_1 , and if these small displacements are projected onto the direction r_1 , then

$$r_1 + dr_1 = r_1 - u dt \cdot \cos \mathcal{G} + u' dt \cdot \cos \mathcal{G}',$$

in which dr_1 denotes the change of length of the straight line connecting the two positive masses during the time element dt . From this follows

$$\frac{dr_1}{dt} = -u \cos \mathcal{G} + u' \cos \mathcal{G}'.$$

Likewise there results for the two negative masses $-\alpha e$ and $-\alpha' e'$:

$$\frac{dr_2}{dt} = +u \cos \mathcal{G} - u' \cos \mathcal{G}';$$

further, for the positive $+\alpha e$ and for the negative $-\alpha' e'$:

$$\frac{dr_3}{dt} = -u \cos \mathcal{G} - u' \cos \mathcal{G}';$$

finally for the negative $-\alpha e$ and for the positive $+\alpha' e'$:

$$\frac{dr_4}{dt} = +u \cos \mathcal{G} + u' \cos \mathcal{G}'.$$

Hence,

$$\left(\frac{dr_1^2}{dt^2} + \frac{dr_2^2}{dt^2} - \frac{dr_3^2}{dt^2} - \frac{dr_4^2}{dt^2} \right) = -8uu' \cos \mathcal{G} \cos \mathcal{G}'.$$

Now, since, further, the velocities u and u' are constant, when the *changes* in the angles \mathcal{G} and \mathcal{G}' (which themselves of course have the same value at the moment under consideration for all four pairs of masses, but which values change with time and become unequal) during the time element dt , are denoted

for the first pair of masses, $d\mathcal{G}_1$ and $d\mathcal{G}'_1$

for the second pair of masses, $d\mathcal{G}_2$ and $d\mathcal{G}'_2$

for the third pair of masses, $d\mathcal{G}_3$ and $d\mathcal{G}'_3$

for the fourth pair of masses, $d\mathcal{G}_4$ and $d\mathcal{G}'_4$,

there results through differentiation of the first differential coefficients:

$$\frac{d^2 r_1}{dt^2} = +u \sin \mathcal{G} \cdot \frac{d\mathcal{G}_1}{dt} - u' \sin \mathcal{G}' \cdot \frac{d\mathcal{G}'_1}{dt},$$

⁴¹ [N. E.] Page 137 of Weber's *Werke*, Vol. 3.

$$\begin{aligned}\frac{d^2 r_2}{dt^2} &= -u \sin \vartheta \cdot \frac{d\vartheta_2}{dt} + u' \sin \vartheta' \cdot \frac{d\vartheta'_2}{dt}, \\ \frac{d^2 r_3}{dt^2} &= +u \sin \vartheta \cdot \frac{d\vartheta_3}{dt} + u' \sin \vartheta' \cdot \frac{d\vartheta'_3}{dt}, \\ \frac{d^2 r_4}{dt^2} &= -u \sin \vartheta \cdot \frac{d\vartheta_4}{dt} - u' \sin \vartheta' \cdot \frac{d\vartheta'_4}{dt}.\end{aligned}$$

Hence

$$\begin{aligned}\left(\frac{d^2 r_1}{dt^2} + \frac{d^2 r_2}{dt^2} - \frac{d^2 r_3}{dt^2} - \frac{d^2 r_4}{dt^2}\right) &= +u \sin \vartheta \left(\frac{d\vartheta_1}{dt} - \frac{d\vartheta_2}{dt} - \frac{d\vartheta_3}{dt} + \frac{d\vartheta_4}{dt}\right) \\ &- u' \sin \vartheta' \left(\frac{d\vartheta'_1}{dt} - \frac{d\vartheta'_2}{dt} + \frac{d\vartheta'_3}{dt} - \frac{d\vartheta'_4}{dt}\right).\end{aligned}$$

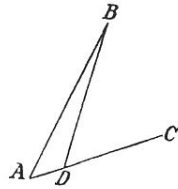

Fig. 18.

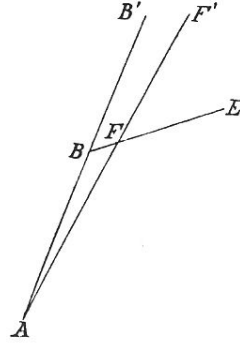

Fig. 19.

Now, let AB in Figure 18 represent the line r . Let the mass $+\alpha e$ be located at A and move in the direction AC with the velocity $+u$ in the time element dt through $AD = +udt$. The angle which the current direction AC forms with AB , is $BAC = \vartheta$. As a result of the motion of A to D , the angle BAC becomes BDC , and

$$BDC = BAC + ABD = \vartheta + \frac{udt}{r} \sin \vartheta.$$

The line AB in Figure 19, which again represents r , is extended to B' . The mass $+\alpha' e'$ is located at B and moves in the direction BE with velocity $+u'$ in the time element dt through $BF = +u'dt$. The angle which the current direction BE forms with BB' , is $B'BE = \vartheta'$. As a result of the motion of B to F , the angle $B'BE$ becomes $F'FE$, and

$$\vartheta' = B'BE = AFB + BAF = F'FE + \frac{u'dt}{r} \sin \vartheta',$$

accordingly is

$$F'FE = \vartheta' - \frac{u'dt}{r} \sin \vartheta'.$$

Finally, if, through the center of a sphere, lines are drawn parallel to the direction AB and to the two current directions AC and BE in Figs. 18 and 19, which cut the sphere's surface at R , U , and U' in Figure 20, and R is connected with U and U' by the arcs of great circles, then the plane of the arc $UR = \vartheta$ is parallel to the plane BAC in Figure 18, and the plane of the arc $U'R = \vartheta'$ is parallel to the plane $B'BE$ in Figure 19, and the angle formed by the two planes at R is the angle denoted ω .

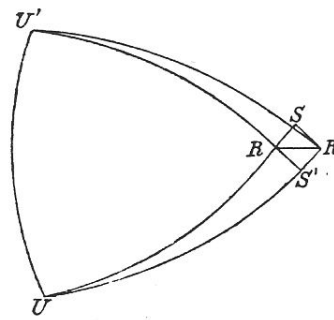

Fig. 20.

Let arc UR be extended to S , $U'R$ to S' , and make

$$RS = +\frac{udt}{r} \sin \mathcal{G}', \quad RS' = -\frac{u'dt}{r} \sin \mathcal{G}' .$$

Then US is the arc of the angle BDC in Figure 18, and $U'S'$ is the arc of the angle $F'FE$ in Figure 19. The element of the surface of the sphere, in which R , S , and S' lie, can also be considered as an element of the plane touching the surface of the sphere at R , and the arc elements RS and RS' as straight lines in this plane. If the parallelogram $RSR'S'$ is completed in this plane, then a line drawn through the center of the sphere parallel to the straight line connecting both masses at the end of the time element dt , goes through the point R' . From this it follows that the direction of this straight line is changed by the simultaneous motion of both masses exactly as it would change, if the one mass were at rest and its motion, taken as being opposite, were attributed to the other mass. Both motions, transferred to a point in this way, can then be combined according to the law of parallelograms, and the cited result is obtained.

Finally, if R' is connected with U and U' by means of the great circle arcs, then

$$UR' = \mathcal{G} + d\mathcal{G}_1 = UR + d\mathcal{G}_1$$

$$U'R' = \mathcal{G}' + d\mathcal{G}'_1 = U'R + d\mathcal{G}'_1 .$$

It follows that:

$$d\mathcal{G}_1 = UR' - UR = RS + RS' \cos \omega$$

$$d\mathcal{G}'_1 = U'R' - U'R = RS' + RS \cos \omega .$$

Now, since $RS = +\frac{udt}{r} \sin \mathcal{G}$, $RS' = -\frac{u'dt}{r} \sin \mathcal{G}'$, it follows that:

$$d\mathcal{G}_1 = +\frac{udt}{r} \sin \mathcal{G} - \frac{u'dt}{r} \sin \mathcal{G}' \cos \omega$$

$$d\mathcal{G}'_1 = -\frac{u'dt}{r} \sin \mathcal{G}' + \frac{udt}{r} \sin \mathcal{G} \cos \omega .$$

Accordingly,

$$r \frac{d\mathcal{G}_1}{dt} = +u \sin \mathcal{G} - u' \sin \mathcal{G}' \cos \omega$$

$$r \frac{d\mathcal{G}'_1}{dt} = -u' \sin \mathcal{G}' + u \sin \mathcal{G} \cos \omega .$$

In the same way, there results for the two *negative* masses $-\alpha e$ and $-\alpha' e'$:

$$r \frac{d\mathcal{G}_2}{dt} = -u \sin \mathcal{G} + u' \sin \mathcal{G}' \cos \omega$$

$$r \frac{d\mathcal{G}'_2}{dt} = +u' \sin \mathcal{G}' - u \sin \mathcal{G} \cos \omega,$$

further, for the positive mass $+ae$ and for the negative $-\alpha'e'$:

$$r \frac{d\mathcal{G}'_3}{dt} = +u \sin \mathcal{G} + u' \sin \mathcal{G}' \cos \omega$$

$$r \frac{d\mathcal{G}'_3}{dt} = +u' \sin \mathcal{G}' + u \sin \mathcal{G} \cos \omega,$$

finally, for the negative mass $-ae$ and for the positive $+\alpha'e'$:

$$r \frac{d\mathcal{G}'_4}{dt} = -u \sin \mathcal{G} - u' \sin \mathcal{G}' \cos \omega$$

$$r \frac{d\mathcal{G}'_4}{dt} = -u' \sin \mathcal{G}' - u \sin \mathcal{G} \cos \omega.$$

If these values are now substituted, the following equation is obtained:⁴²

⁴² [N. A.] This equation can also be derived from the equations of motion of the four electrical masses. Let a plane be laid parallel with α' through the element α . Let O be that point in this plane, at which direction α is cut by direction α' , which is projected on this plane. Let O be the origin of the coordinates, direction α as the x axis, and the z axis be perpendicular to the above-mentioned plane. Further, imagine that both masses always move forward uniformly in the same directions, and choose that moment as the initial point of time t , for which the coordinates of the mass later considered in α' are

$$x' = 0, y' = 0, z' = c.$$

If ε then denotes the angle which the directions α and α' form with each other, x, y, z the coordinates of the mass later considered in α , and u and u' the velocities of both masses, then the equations of motion are

for the one mass:

$$\begin{aligned} x &= b + ut \\ y &= 0 \\ z &= 0 \end{aligned}$$

for the other mass:

$$\begin{aligned} x' &= u't \cdot \cos \varepsilon \\ y' &= u't \cdot \sin \varepsilon \\ z' &= c \end{aligned}$$

where b and c are given constants. Accordingly,

$$\begin{aligned} x' - x &= (u' \cos \varepsilon - u) \cdot t - b \\ y' - y &= u't \cdot \sin \varepsilon \\ z' - z &= c \end{aligned}$$

and, since $r_1^2 = (x' - x)^2 + (y' - y)^2 + (z' - z)^2$,

$$r_1^2 = [(u' \cos \varepsilon - u) \cdot t - b]^2 + u'^2 t^2 \sin^2 \varepsilon + c^2.$$

If this equation is differentiated with respect to r_1 and t , one obtains:

$$\frac{dr_1}{dt} = \frac{1}{r_1} \cdot [(u' \cos \varepsilon - u) \cdot t - b] (u' \cos \varepsilon - u) + u'^2 t \cdot \sin^2 \varepsilon,$$

and, through repeated differentiation,

$$r_1 \frac{d^2 r_1}{dt^2} + \frac{dr_1^2}{dt^2} = u^2 + u'^2 - 2uu' \cos \varepsilon.$$

Now, for the moment where the two masses have reached α and α' , if \mathcal{G} denotes the angle which the direction from α to α' forms with the *first* coordinate axis,

$$x' - x = r_1 \cos \mathcal{G}.$$

If lines are drawn parallel with the three coordinates, further with the direction from α to α' , and finally with the direction α' itself, through the center of a sphere, whose surface is cut into

X, Y, Z, R and P ,

then RY is the arc of the angle, which the line from α to α' forms with the *second* coordinate axis, and hence for the moment, where the two masses reach α and α' ,

$$y' - y = r_1 \cos RY.$$

$$r \left(\frac{d^2 r_1}{dt^2} + \frac{d^2 r_2}{dt^2} - \frac{d^2 r_3}{dt^2} - \frac{d^2 r_4}{dt^2} \right) = -8uu' \sin \mathcal{G} \sin \mathcal{G}' \cos \omega.$$

If these values and those found for $\left(\frac{dr_1^2}{dt^2} + \frac{dr_2^2}{dt^2} - \frac{dr_3^2}{dt^2} - \frac{dr_4^2}{dt^2} \right)$ are substituted in the above expression for the resultant of four partial effects, then one obtains the following values for it:

$$-\frac{\alpha\alpha'}{r^2} \cdot aeu \cdot ae'u' \left(\sin \mathcal{G} \sin \mathcal{G}' \cos \omega - \frac{1}{2} \cos \mathcal{G} \cos \mathcal{G}' \right).$$

If one substitutes here, according to page 94,⁴³

$$aeu = i, \quad ae'u' = i',$$

then, according to this derivation from the established fundamental electrical law, there results for the repulsive force of two current elements the same value as according to Ampère's law, namely:

$$-\frac{\alpha\alpha'}{r^2} ii' \left(\sin \mathcal{G} \sin \mathcal{G}' \cos \omega - \frac{1}{2} \cos \mathcal{G} \cos \mathcal{G}' \right),$$

or, when ε denotes the angle which the two elements α and α' themselves make, and where then $\cos \varepsilon = \sin \mathcal{G} \sin \mathcal{G}' \cos \omega + \cos \mathcal{G} \cos \mathcal{G}'$,

Now, however, in the spherical triangles PRX and PRY , because the radius P (which is parallel to the direction α') lies in the same greatest circle with the radii X and Y (which are parallel to the plane of the coordinate axes x and y),

$$\cos RX \sin PY + \cos RY \sin PX = \cos PR \sin XY,$$

and further,

$$XY = 90^\circ, \quad PX = \varepsilon, \quad RX = \mathcal{G}, \quad PR = \mathcal{G}',$$

where \mathcal{G}' denotes the angle which the line from α to α' forms with the direction of α' itself. If these values are substituted, there results

$$\cos RY = \frac{\cos \mathcal{G}' - \cos \mathcal{G} \cos \varepsilon}{\sin \varepsilon},$$

hence

$$y' - y = r_1 \cdot \frac{\cos \mathcal{G}' - \cos \mathcal{G} \cos \varepsilon}{\sin \varepsilon}.$$

If t in the above equations now denotes for $x' - x$ and $y' - y$ those values, which correspond to the moments at which the two masses reach α and α' , then the above values of $x' - x$ and $y' - y$ are to be set equal to the ones just found, or

$$(u' \cos \varepsilon - u)t - b = r_1 \cos \mathcal{G}$$

$$u't \cdot \sin \varepsilon = r_1 \cdot \frac{\cos \mathcal{G}' - \cos \mathcal{G} \cos \varepsilon}{\sin \varepsilon}.$$

If these values are substituted in the expression for $\frac{dr_1}{dt}$, the result is:

$$\frac{dr_1}{dt} = +u' \cos \mathcal{G}' - u \cos \mathcal{G}.$$

If from this is subtracted the square of the value found for $r_1 \frac{d^2 r_1}{dt^2} + \frac{dr_1^2}{dt^2}$, then it remains the case that

$$r_1 \frac{d^2 r_1}{dt^2} = u^2 \sin^2 \mathcal{G} + u'^2 \sin^2 \mathcal{G}' - 2uu'(\cos \varepsilon - \cos \mathcal{G} \cos \mathcal{G}')$$

or, if the angle ω is introduced, in accordance with the equation $\cos \varepsilon = \sin \mathcal{G} \sin \mathcal{G}' \cos \omega + \cos \mathcal{G} \cos \mathcal{G}'$,

$$r_1 \frac{d^2 r_1}{dt^2} = u^2 \sin^2 \mathcal{G} + u'^2 \sin^2 \mathcal{G}' - 2uu' \sin \mathcal{G} \sin \mathcal{G}' \cos \omega.$$

The corresponding differential coefficients of the other pairs of masses are found in the same way, which then together give the above equation.

⁴³ [N. E.] Page 152 of Weber's *Werke*, Vol. 3.

$$-\frac{\alpha\alpha'}{r^2}ii'\left(\cos\varepsilon - \frac{3}{2}\cos\vartheta\cos\vartheta'\right).$$

The actions at a distance of *uniform* electrical currents in conducting wires *at rest* are hereby fully determined. The derivations of the established fundamental law carried out up to now are all empirically confirmed.

Theory of Volta-induction.

23.

It still remains to develop, from the established fundamental electrical law, the effects of *variable* electrical currents in *moving* conductors, which development comprises the *theory of voltaic induction*.

Voltaic induction differentiates itself from Ampère's *electrodynamics* in that it has to do with the *generation* of currents, which is wholly excluded from the latter.

The following is *empirically* known about voltaic induction. We know, first, that it can be elicited in two essentially different ways: namely, currents can be induced by means of *constant* currents and by means of *variable* ones. Induction occurs by means of *constant* currents, either when a conducting wire, through which the constant current is passing, approaches the conducting wire in which a current is to be induced, or is moved away from it, or when, vice versa, the latter approaches the former or is moved away from it. It seems to be a matter of indifference for the effect, whether only the one, or only the other wire, or both alike are moved, provided that their *relative* motion is the same. If the two wires are parallel to each other, then a current of opposite direction will be induced by bringing them closer, a current of like direction will be induced by drawing them apart. Induction occurs by means of *variable* currents, even when the conducting wire, through which the variable current passes, remains undisturbed with respect to the wire in which a current is to be induced. If the two wires are parallel to each other, increasing current intensity induces a current of opposite direction, decreasing intensity a current of like direction.

We empirically know, *secondly*, that the induction caused by a constant current in a conducting wire moving toward it is the same as the induction caused by a magnet in the same conducting wire, if the electrodynamic force of repulsion or attraction, which that current would exert on this conducting wire when a determined current passed through the latter, is equal to the electromagnetic force, which the magnet would exert on the same wire under the same conditions. See Section 11, page 61.⁴⁴

These empirical findings can serve to test the correctness of the laws of voltaic induction which are to be established.

Moreover, it should be noted, that the theory of *voltaic induction* is a theory of *electromotive forces*, by means of which the *induced currents* themselves are still not completely determined. In order to completely determine the *induced currents* themselves, also according to their *intensity*, as well as the electrodynamic forces of repulsion and attraction and secondary inductions which they themselves further elicit, it requires, besides the determination of the *electromotive force* to be drawn from the theory of *voltaic induction*, a statement of the *resistance* of the entire circuit to which the induced conducting wire belongs, as is obvious from the dependency defined by Ohm's law of the current intensity on the electromotive force and the total resistance of the circuit.

⁴⁴ [N. E.] Page 103 of Weber's *Werke*, Vol. 3.

The complete development of the effects of *non-uniform* electrical currents in *moving* conductors comprises, finally, not merely the *theory of voltaic induction*, that is to say, it not merely accounts for the generation, strengthening, and weakening of currents in the ponderable conductors, but it also encompasses all *electrodynamic* forces of repulsion and attraction, which are effects of the above-cited currents, and which move the ponderable currents themselves.

In the following Sections, we intend *first* to begin with a prefatory consideration of particular cases, and *then* to follow with the general development of the effects of electrical currents which are *not uniform*, as they take place in *galvanic currents* of variable intensity, while the ponderable conductors are *in motion*.

24.

Law of exciting a current in a conductor, which approaches a constant current element at rest, or is distanced from it.

The simplest case of *voltaic induction* to which the established fundamental law can be applied, is the one in which, of the two elements, only one, namely, the inducing one, already contains a current, specifically, a current of constant intensity, and the distance between the two elements is altered simply by means of the motion of the other element, namely, the induced one.

If α now denotes the length of the inducing element, α' the length of the induced element, then four electrical masses are to be differentiated in these two elements, namely:

$$+ae, -ae, +\alpha'e', -\alpha'e'.$$

The *first* of these masses, $+ae$, moves with *constant* velocity $+u$ in the direction of the element *at rest* α , which forms the angle \mathcal{G} with the straight line drawn from α to α' ; the *second*, $-ae$, moves in the same direction with velocity $-u$, viz., backwards; the *third*, $+\alpha'e'$, which indeed rests in the element α' , is *carried forward* by it with velocity $+u'$ in that direction which forms the angle \mathcal{G}' with the extended straight line drawn from α to α' ; and with the same straight line, lies in a plane, which, with the plane containing element α and that straight line, forms the angle ω ; the *fourth*, finally, $-\alpha'e'$, which likewise rests in element α' , is carried forward by this element with the same velocity $+u'$ in the same direction as the third mass. The distances of the first two masses from the second two are all equal at the moment in question to distance r , at which the elements α and α' are found at that moment; since, however, they do not remain equal, they are denoted,⁴⁵ as on page 99,⁴⁶ r_1, r_2, r_3, r_4 .

The application of the fundamental law then yields, as on page 99,⁴⁷ the following four partial effects among these four masses:

$$\begin{aligned} & + \frac{ae \cdot \alpha'e'}{r_1^2} \left(1 - \frac{a^2}{16} \frac{dr_1^2}{dt^2} + \frac{a^2}{8} r_1 \frac{d^2 r_1}{dt^2} \right) \\ & + \frac{ae \cdot \alpha'e'}{r_2^2} \left(1 - \frac{a^2}{16} \frac{dr_2^2}{dt^2} + \frac{a^2}{8} r_2 \frac{d^2 r_2}{dt^2} \right) \\ & - \frac{ae \cdot \alpha'e'}{r_3^2} \left(1 - \frac{a^2}{16} \frac{dr_3^2}{dt^2} + \frac{a^2}{8} r_3 \frac{d^2 r_3}{dt^2} \right) \end{aligned}$$

⁴⁵ [N. E.] See beginning of Section 28.

⁴⁶ [N. E.] Page 158 of Weber's *Werke*, Vol. 3.

⁴⁷ [N. E.] Page 158 of Weber's *Werke*, Vol. 3.

$$-\frac{\alpha e \cdot \alpha' e'}{r_4^2} \left(1 - \frac{a^2}{16} \frac{dr_4^2}{dt^2} + \frac{a^2}{8} r_4 \frac{d^2 r_4}{dt^2} \right)$$

These four partial effects can now first be combined into two forces, of which one is the action of the two masses of the inducing elements $+ae$ and $-ae$ on the *positive* mass $+\alpha'e'$ of the induced element, the other the action of the same masses on the *negative* mass $-\alpha'e'$ of the induced element. The former force is the sum of the first and fourth, the latter is the sum of the second and third. The former force is thus, with regard to the equality of r_1 , r_2 , r_3 and r_4 with r at the moment in question,

$$= -\frac{a^2}{16} \cdot \frac{\alpha e \cdot \alpha' e'}{r^2} \left\{ \left(\frac{dr_1^2}{dt^2} - \frac{dr_4^2}{dt^2} \right) - 2r \left(\frac{d^2 r_1}{dt^2} - \frac{d^2 r_4}{dt^2} \right) \right\};$$

the latter force is

$$= -\frac{a^2}{16} \cdot \frac{\alpha e \cdot \alpha' e'}{r^2} \left\{ \left(\frac{dr_2^2}{dt^2} - \frac{dr_3^2}{dt^2} \right) - 2r \left(\frac{d^2 r_2}{dt^2} - \frac{d^2 r_3}{dt^2} \right) \right\}.$$

Now, insofar as the motions elicited by these forces in both electrical masses, $+\alpha'e'$ and $-\alpha'e'$, in their ponderable carrier α' are cancelled almost instantaneously by the *resistance* of the carrier, and thereby all the forces acting on those masses are immediately transferred to this carrier, the *sums* of the above two forces, as on page 100,⁴⁸ gives the force which moves the carrier α' itself,

$$= -\frac{a^2}{16} \cdot \frac{\alpha e \cdot \alpha' e'}{r^2} \left\{ \left(\frac{dr_1^2}{dt^2} + \frac{dr_2^2}{dt^2} - \frac{dr_3^2}{dt^2} - \frac{dr_4^2}{dt^2} \right) - 2r \left(\frac{d^2 r_1}{dt^2} + \frac{d^2 r_2}{dt^2} - \frac{d^2 r_3}{dt^2} - \frac{d^2 r_4}{dt^2} \right) \right\}.$$

Before the transference to their carriers of those forces which originally acted on the electrical masses, the electrical forces themselves are, however, somewhat displaced in their carriers, and when this displacement is *different* for the positive mass $+\alpha'e'$ and the negative mass $-\alpha'e'$, the two thus being thereby *separated* from each other, then a galvanic current is produced in carrier α' , and the force which effects this separation, is called the *electromotive force*. It is clear, that this *electromotive force* depends upon the *difference* of the above two forces, i.e., on

$$-\frac{a^2}{16} \cdot \frac{\alpha e \cdot \alpha' e'}{r^2} \left\{ \left(\frac{dr_1^2}{dt^2} - \frac{dr_2^2}{dt^2} + \frac{dr_3^2}{dt^2} - \frac{dr_4^2}{dt^2} \right) - 2r \left(\frac{d^2 r_1}{dt^2} - \frac{d^2 r_2}{dt^2} + \frac{d^2 r_3}{dt^2} - \frac{d^2 r_4}{dt^2} \right) \right\}.$$

According to the determinations given in Section 22 for *two constant* current elements *at rest* in relation to the motion of their electrical masses, the value obtained there for that former *sum* was equal to the force determined by Ampère's law,

$$= -\frac{\alpha \alpha'}{r^2} ii' \left(\cos \varepsilon - \frac{3}{2} \cos \vartheta \cos \vartheta' \right);$$

there the value of this latter *difference* would then, however, be

$$= 0.$$

According to the determinations given in this Section for a *constant* current element *at rest* and for a *moving* wire element *without current* with respect to their electrical masses, the value of that former *sum*, however,

$$= 0,$$

and the value of this latter *difference*

$$= -\frac{\alpha \alpha'}{r^2} ae' u' i \left(\cos \varepsilon - \frac{3}{2} \cos \vartheta \cos \vartheta' \right),$$

⁴⁸ [N. E.] Page 159 of Weber's *Werke*, Vol. 3.

as is to be proven in what follows.

It is merely necessary for this purpose, in the differential coefficients determined on page 100,⁴⁹ to put $+u'$ instead of $-u'$ for the velocity of the *negative* mass; one then obtains:

$$\frac{dr_1}{dt} = \frac{dr_3}{dt} = -u \cos \mathcal{G} + u' \cos \mathcal{G}'$$

$$\frac{dr_2}{dt} = \frac{dr_4}{dt} = +u \cos \mathcal{G} + u' \cos \mathcal{G}' .$$

Hence, then

$$\frac{dr_1^2}{dt^2} + \frac{dr_2^2}{dt^2} - \frac{dr_3^2}{dt^2} - \frac{dr_4^2}{dt^2} = 0 .$$

On the other hand:

$$\frac{dr_1^2}{dt^2} - \frac{dr_2^2}{dt^2} + \frac{dr_3^2}{dt^2} - \frac{dr_4^2}{dt^2} = -8uu' \cos \mathcal{G} \cos \mathcal{G}' .$$

Further, one obtains:

$$\frac{d^2 r_1}{dt^2} = +u \sin \mathcal{G} \cdot \frac{d\mathcal{G}_1}{dt} - u' \sin \mathcal{G}' \cdot \frac{d\mathcal{G}'_1}{dt}$$

$$\frac{d^2 r_2}{dt^2} = -u \sin \mathcal{G} \cdot \frac{d\mathcal{G}_2}{dt} - u' \sin \mathcal{G}' \cdot \frac{d\mathcal{G}'_2}{dt}$$

$$\frac{d^2 r_3}{dt^2} = +u \sin \mathcal{G} \cdot \frac{d\mathcal{G}_3}{dt} - u' \sin \mathcal{G}' \cdot \frac{d\mathcal{G}'_3}{dt}$$

$$\frac{d^2 r_4}{dt^2} = -u \sin \mathcal{G} \cdot \frac{d\mathcal{G}_4}{dt} - u' \sin \mathcal{G}' \cdot \frac{d\mathcal{G}'_4}{dt} ,$$

hence:

$$\frac{d^2 r_1}{dt^2} + \frac{d^2 r_2}{dt^2} - \frac{d^2 r_3}{dt^2} - \frac{d^2 r_4}{dt^2} = +u \sin \mathcal{G} \left(\frac{d\mathcal{G}_1}{dt} - \frac{d\mathcal{G}_2}{dt} - \frac{d\mathcal{G}_3}{dt} + \frac{d\mathcal{G}_4}{dt} \right)$$

$$- u' \sin \mathcal{G}' \left(\frac{d\mathcal{G}'_1}{dt} + \frac{d\mathcal{G}'_2}{dt} - \frac{d\mathcal{G}'_3}{dt} + \frac{d\mathcal{G}'_4}{dt} \right) .$$

In contrast is

$$\frac{d^2 r_1}{dt^2} - \frac{d^2 r_2}{dt^2} + \frac{d^2 r_3}{dt^2} - \frac{d^2 r_4}{dt^2} = +u \sin \mathcal{G} \left(\frac{d\mathcal{G}_1}{dt} + \frac{d\mathcal{G}_2}{dt} + \frac{d\mathcal{G}_3}{dt} + \frac{d\mathcal{G}_4}{dt} \right)$$

$$- u' \sin \mathcal{G}' \left(\frac{d\mathcal{G}'_1}{dt} - \frac{d\mathcal{G}'_2}{dt} + \frac{d\mathcal{G}'_3}{dt} - \frac{d\mathcal{G}'_4}{dt} \right) .$$

Further, according to page 102 f.,⁵⁰ if one also attributes the velocity $+u'$ to the *negative* mass of the induced element $-\alpha'e'$, it follows that

$$r \frac{d\mathcal{G}_1}{dt} = r \frac{d\mathcal{G}_3}{dt} = +u \sin \mathcal{G} - u' \sin \mathcal{G}' \cos \omega$$

$$r \frac{d\mathcal{G}_2}{dt} = r \frac{d\mathcal{G}_4}{dt} = -u \sin \mathcal{G} - u' \sin \mathcal{G}' \cos \omega$$

$$r \frac{d\mathcal{G}'_1}{dt} = r \frac{d\mathcal{G}'_3}{dt} = -u' \sin \mathcal{G}' + u \sin \mathcal{G} \cos \omega$$

⁴⁹ [N. E.] Page 159 of Weber's *Werke*, Vol. 3.

⁵⁰ [N. E.] Page 162 f. of Weber's *Werke*, Vol. 3.

$$r \frac{d\mathcal{G}'_2}{dt} = r \frac{d\mathcal{G}'_4}{dt} = -u' \sin \mathcal{G}' - u \sin \mathcal{G} \cos \omega,$$

from which it results that:

$$r \left(\frac{d\mathcal{G}'_1}{dt} - \frac{d\mathcal{G}'_2}{dt} - \frac{d\mathcal{G}'_3}{dt} + \frac{d\mathcal{G}'_4}{dt} \right) = r \left(\frac{d\mathcal{G}'_1}{dt} + \frac{d\mathcal{G}'_2}{dt} - \frac{d\mathcal{G}'_3}{dt} - \frac{d\mathcal{G}'_4}{dt} \right) = 0;$$

however, on the other hand,

$$\begin{aligned} r \left(\frac{d\mathcal{G}'_1}{dt} + \frac{d\mathcal{G}'_2}{dt} + \frac{d\mathcal{G}'_3}{dt} + \frac{d\mathcal{G}'_4}{dt} \right) &= -4u' \sin \mathcal{G}' \cos \omega \\ r \left(\frac{d\mathcal{G}'_1}{dt} - \frac{d\mathcal{G}'_2}{dt} + \frac{d\mathcal{G}'_3}{dt} - \frac{d\mathcal{G}'_4}{dt} \right) &= +4u \sin \mathcal{G} \cos \omega. \end{aligned}$$

From this it follows that:

$$\begin{aligned} r \left(\frac{d^2 r_1}{dt^2} + \frac{d^2 r_2}{dt^2} - \frac{d^2 r_3}{dt^2} - \frac{d^2 r_4}{dt^2} \right) &= 0 \\ r \left(\frac{d^2 r_1}{dt^2} - \frac{d^2 r_2}{dt^2} + \frac{d^2 r_3}{dt^2} - \frac{d^2 r_4}{dt^2} \right) &= -8uu' \sin \mathcal{G} \sin \mathcal{G}' \cos \omega. \end{aligned}$$

Substituting these values, it is obtained the *sum* of both forces, which act at the *positive* and *negative* masses of the induced element,

$$= 0,$$

in contrast, their *difference* is

$$= -\frac{\alpha\alpha'}{r^2} aeu \cdot ae'u' \left(\sin \mathcal{G} \sin \mathcal{G}' \cos \omega - \frac{1}{2} \cos \mathcal{G} \cos \mathcal{G}' \right),$$

or, since, according to page 104,⁵¹ $\cos \varepsilon = \sin \mathcal{G} \sin \mathcal{G}' \cos \omega + \cos \mathcal{G} \cos \mathcal{G}'$ and according to page 94,⁵² $aeu = i$,

$$= -\frac{\alpha\alpha'}{r^2} i \cdot ae'u' \left(\cos \varepsilon - \frac{3}{2} \cos \mathcal{G} \cos \mathcal{G}' \right),$$

which was to be proven.

Now, the force hereby determined seeks to separate from each other the *positive* and *negative* electricities in the induced element α' in the direction of the straight line r . In reality, however, this separation can only ensue in the direction of α' , because in a linear conductor, a galvanic current can only take place in the direction of the conductor. Hence, if one takes the components of the above force in the direction of element α' and perpendicular to it, then only the first part comes under consideration as *electromotive* force, and, if φ denotes the angle which the element α' makes with the extended straight line r , this term is

$$= -\frac{\alpha\alpha'}{r^2} i \left(\cos \varepsilon - \frac{3}{2} \cos \mathcal{G} \cos \mathcal{G}' \right) \cdot ae'u' \cos \mathcal{G}.$$

Ordinarily, by *electromotive force* is understood the accelerating force which the given absolute force exerts on the electrical mass e' contained in the unit of length of the induced conducting wire, which is obtained by division of the above value by e' . Finally, the *electromotive force* of a constant current element at rest on a moving wire element would hence be maintained as

$$= -\frac{\alpha\alpha'}{r^2} i \left(\cos \varepsilon - \frac{3}{2} \cos \mathcal{G} \cos \mathcal{G}' \right) \cdot au' \cos \mathcal{G}.$$

⁵¹ [N. E.] Page 164 of Weber's *Werke*, Vol. 3.

⁵² [N. E.] Page 152 of Weber's *Werke*, Vol. 3.

Now, accordingly as this expression has a *positive* or *negative* value, the inducing current is *positive* or *negative*, where by positive currents is understood one whose positive electricity moves in that direction of element α' which forms the angle φ with the extended straight line r .

If, for example, the elements α and α' are parallel to each other, and the direction in which the latter moves with velocity $+u'$ is in the plane of both elements and perpendicular to them, then, when α' *distances itself* from α by means of its motion,

$$\mathcal{G} = \varphi, \quad \cos \mathcal{G}' = \sin \mathcal{G}, \quad \cos \varepsilon = 0,$$

hence the *electromotive force*

$$= +\frac{3}{2} \frac{\alpha\alpha'}{r^2} i \sin \mathcal{G} \cos^2 \mathcal{G} \cdot au'.$$

This value is always *positive*, when $\mathcal{G} < 180^\circ$, and this *positive* value here denotes an induced current of the same direction as the inducing, in accord with what empirical experience has yielded for this case.

Under the same conditions, with the mere difference that the element α' *approaches* the element α by means of its motion,

$$\mathcal{G} = \varphi, \quad \cos \mathcal{G}' = -\sin \mathcal{G}, \quad \cos \varepsilon = 0,$$

hence the *electromotive force*

$$= -\frac{3}{2} \frac{\alpha\alpha'}{r^2} i \sin \mathcal{G} \cos^2 \mathcal{G} \cdot au'.$$

The *negative* value of this force denotes an induced current of opposite direction from the inducing one, likewise in accord with what empirical experience has yielded for this case.

25.

Comparison with the empirical propositions in Section 11.

The experiments communicated in Sections 10 and 11 relate to the case of *voltaic induction* considered in the previous Section. For *quantitative* determination of *voltaic induction* in this case, the proposition has been set forth and empirically tested there,

that the induction by a constant current at rest in a conducting wire in motion toward it is the same, as the induction in the same conducting wire by a magnet, if the electrodynamic force, which that constant current would exert on that conducting wire with a current flowing through it, were equal to the electromagnetic force, which the magnet would exert on the wire through which the same current were flowing.

In order to empirically establish this proposition, the following experiments were made:

1. the *electrodynamic* force was measured, which a closed circuit A did exert on another closed circuit B ;

2. the closed circuit A was replaced with a magnet C , and the electromagnetic force which C did exert on B was measured;

3. the closed conductor B , without current, was put into a specific motion, and the current was measured, which was then produced by current A in the moving conductor by means of *voltaic induction*;

4. given the same motion of the closed conductor B , the current produced by means of *magnetic induction* by the magnet C , which had been substituted for the current A was measured.

In conformity with these four experiments, the following four laws are now to be listed for comparison:

1. the law of the *electrodynamic* action of a closed circuit on a current element;
2. the law of the *electromagnetic* action of a magnet on a current element;
3. the law of *voltaic induction* by a closed circuit in an element of a moving conductor;
4. the law of *magnetic induction* by a magnet in an element of a moving conductor.

1. *The law of the electrodynamic action of a closed circuit on a current element.*

This law is developed on page 48 in Section 3 of the footnote,⁵³ for the case where the closed circuit delimits a plane and acts at a distance. Instead of returning to this special law, here I shall return to the more general one which Ampère has given on page 214 of his Treatise, and which is presented on page 36 of this Treatise.⁵⁴ According to this law, the electrodynamic force acting on the current element α' is decomposed along three right-angled coordinate axes, whose origin lies in the center of element α' , into the components X, Y, Z , which are defined as follows:

$$X = -\frac{ii'}{2}\alpha'(C \cos \mu - B \cos \nu)$$

$$Y = -\frac{ii'}{2}\alpha'(A \cos \nu - C \cos \lambda)$$

$$Z = -\frac{ii'}{2}\alpha'(B \cos \lambda - A \cos \mu),$$

in which $A = \int \frac{ydz - zdy}{r^3}$, $B = \int \frac{zdx - xdz}{r^3}$, $C = \int \frac{xdy - ydx}{r^3}$, α' denotes the length of the current element which is acted upon, λ, μ, ν the angle which α' forms with the three coordinate axes, and i and i' the intensities of the closed current and of the current element.

2. *The law of the electrodynamic action of a magnet on a current element.*

According to the fundamental law of electromagnetism, the electromagnetic force which a mass of north or south magnetic fluid $\pm \mu$ exerts on a current element of length α' and of current intensity i' at distance r , when φ denotes the angle which α' forms with r , is represented by

$$\pm \frac{i'\alpha'}{\sqrt{2}} \cdot \frac{\mu \sin \varphi}{r^2}$$

in which $i'\sqrt{\frac{1}{2}}$ replaces χ' according to page 48,⁵⁵ and this force seeks to move the current element in a direction perpendicular to α' and r . Thus from this derive the magnitude and direction of both forces, which the two masses of north and south magnetic fluid contained in a *small* magnet exert on the current element. These two forces can be combined according to the law of parallelograms, and from this results the *magnitude* of the resultant, when⁵⁶ m' denotes the magnetic moment and ψ denotes the angle which the magnetic axis makes with the straight line r , and ε the angle which direction α' makes with the direction D lying in the plane of the magnetic

⁵³ [N. E.] Page 86 of Weber's *Werke*, Vol. 3.

⁵⁴ [N. E.] Page 70 of Weber's *Werke*, Vol. 3.

⁵⁵ [N. E.] Page 86 of Weber's *Werke*, Vol. 3.

⁵⁶ [N. E.] In the original it appears m instead of m' .

axis and of line r , and the sine of this angle with line r is to $\sin \psi$ as 1 : the square root of $1 + 3 \cos^2 \psi$, and finally, if for the sake of brevity, $\frac{1}{r^3} \sqrt{1 + 3 \cos^2 \psi}$ is denoted by \bar{d} ,

$$= \frac{i'}{\sqrt{2}} \alpha' m' \bar{d} \sin \varepsilon .$$

The *direction* of this resultant is perpendicular to the directions α' and D . If, now, one denotes by a, b, c

the cosines of the angles which the resultant, thus determined, forms with three right-angled coordinate axes, whose origin lies in the center of element α' , and decomposes the resultant according to the direction of the latter, then the following three components are obtained:

$$\begin{aligned} & \frac{i'}{\sqrt{2}} \cdot \alpha' m' a \bar{d} \sin \varepsilon \\ & \frac{i'}{\sqrt{2}} \cdot \alpha' m' b \bar{d} \sin \varepsilon \\ & \frac{i'}{\sqrt{2}} \cdot \alpha' m' c \bar{d} \sin \varepsilon \end{aligned}$$

and for a, b, c the following equations are obtained, when the angles which the direction of element α' forms with the coordinate axes are denoted

$$\lambda, \mu, \nu,$$

and the cosines of the angles which the direction D forms with the same coordinate axes are denoted

$$\bar{a}, \quad \bar{b}, \quad \bar{c},$$

namely:

$$\begin{aligned} a\bar{a} + b\bar{b} + c\bar{c} &= 0 \\ a \cos \lambda + b \cos \mu + c \cos \nu &= 0 \\ a\bar{a} + b\bar{b} + c\bar{c} &= 1 \\ \frac{\bar{a}}{\bar{d}} \cos \lambda + \frac{\bar{b}}{\bar{d}} \cos \mu + \frac{\bar{c}}{\bar{d}} \cos \nu &= \cos \varepsilon . \end{aligned}$$

These equations, by elimination of b and c , yield the value of a as

$$a = \frac{\bar{b} \cos \nu - \bar{c} \cos \mu}{\sqrt{1 - \left(\frac{\bar{a}}{\bar{d}} \cos \lambda + \frac{\bar{b}}{\bar{d}} \cos \mu + \frac{\bar{c}}{\bar{d}} \cos \nu \right)^2}} = \frac{\bar{b} \cos \nu - \bar{c} \cos \mu}{\bar{d} \sin \varepsilon},$$

and in the same way, the following values of b and c :

$$\begin{aligned} b &= \frac{\bar{c} \cos \lambda - \bar{a} \cos \nu}{\bar{d} \sin \varepsilon} \\ c &= \frac{\bar{a} \cos \mu - \bar{b} \cos \lambda}{\bar{d} \sin \varepsilon} . \end{aligned}$$

If these expressions are substituted into those for the three components of the electromagnetic force, the following values are obtained for the latter:

$$-\frac{i'}{\sqrt{2}} \cdot \alpha' m' (\bar{c} \cos \mu - \bar{b} \cos \nu)$$

$$-\frac{i'}{\sqrt{2}} \cdot \alpha' m' (\bar{a} \cos \nu - \bar{c} \cos \lambda) \\ -\frac{i'}{\sqrt{2}} \cdot \alpha' m' (\bar{b} \cos \lambda - \bar{a} \cos \mu).$$

For a large magnet, which is composed of many small ones, the three components X' , Y' , Z' of the electromagnetic force it exerts on the current element α' are hereafter determined as follows:

$$X' = -\frac{i'}{\sqrt{2}} \cdot \alpha' (C' \cos \mu - B' \cos \nu) \\ Y' = -\frac{i'}{\sqrt{2}} \cdot \alpha' (A' \cos \nu - C' \cos \lambda) \\ Z' = -\frac{i'}{\sqrt{2}} \cdot \alpha' (B' \cos \lambda - A' \cos \mu),$$

in which $A' = S(\bar{a}m')$, $B' = S(\bar{b}m')$, $C' = S(\bar{c}m')$.⁵⁷

3. The law of voltaic induction by a closed circuit in an element of a moving conductor.

The elementary law of induction developed in the previous Section, which holds for any inducing element α , yields the following value for the *electromotive* force with which one such element α seeks to separate from each other the positive and negative electrical masses in the induced element α' in the direction of the straight line r :

$$-\frac{\alpha\alpha'}{r^2} i \left(\cos \varepsilon - \frac{3}{2} \cos \vartheta \cos \vartheta' \right) \cdot au',$$

in which $+u'$ denotes the velocity with which the induced element α' is moved, and ε and ϑ' the angles which the direction of this motion forms with the direction in which the positive electricity flows in the inducing current element α , and with the extended straight line r . ϑ denotes, as in the theory of two constant current elements in Section 22, the angle which the direction in which the positive electricity flows in the first element α , forms with the straight line r .

If this value for the *electromotive* force is compared with the value found on page 104⁵⁸ for the *electrodynamic force* in the theory of two constant current elements, in accordance with Ampère's law, then the following simple relation results between the two, namely, that the former force is obtained from the latter by multiplication with the constant factor au'/i' , provided that the direction, in which the positive electricity flows in element α' , in the latter force, were the same as the direction in which the induced element α' itself moves, in the former force, that is

$$\beta = \lambda, \quad \gamma = \mu, \quad \delta = \nu,$$

when the angle formed by both directions with three right-angled coordinate axes are respectively denoted

$$\lambda, \mu, \nu \text{ and } \beta, \gamma, \delta$$

for then the values of ε and ϑ' are equal in both expressions.

From this it is now obvious, under the presupposition made, that the values stated under (1) for the *electrodynamic force* X, Y, Z also need only to be multiplied by the constant factor au'/i' , in order to obtain the components $\bar{X}, \bar{Y}, \bar{Z}$ of the *electromotive* force which a *closed circuit* exerts on the induced element α' . From this it follows that

⁵⁷ [N. E.] That is, $A' = \int (\bar{a}m')$, $B' = \int (\bar{b}m')$ and $C' = \int (\bar{c}m')$.

⁵⁸ [N. E.] Page 164 of Weber's *Werke*, Vol. 3.

$$\begin{aligned}\bar{X} &= -\frac{au'}{2} \cdot i\alpha'(C \cos \gamma - B \cos \delta) \\ \bar{Y} &= -\frac{au'}{2} \cdot i\alpha'(A \cos \delta - C \cos \beta) \\ \bar{Z} &= -\frac{au'}{2} \cdot i\alpha'(B \cos \beta - A \cos \gamma),\end{aligned}$$

in which A, B, C have the same signification as under (1).

4. *The law of magnetic induction by a magnet in an element of a moving conductor.*

From the *elementary electromagnetic force*, determined according to the basic law of electromagnetism, which a mass of north or south magnetic fluid, $\pm \mu$, exerts on a current element of length α' and of current intensity i' at distance r , when φ denotes the angle which the direction of flow of the positive electricity in α' forms with the straight line r , namely, from the active force cited under (2), normal to the plane parallel with r and α'

$$\pm \frac{i'\alpha'}{\sqrt{2}} \cdot \frac{\mu \sin \varphi}{r^2},$$

we obtain, by multiplication with the constant ku'/i' , according to the basic law of magneto-induction, the *elementary electromotive force* with which that magnetic mass seeks to divide the positive and negative electricity in the induced element α' , in a direction normal to the plane parallel with r and α' , when the induced element α' is moving here with the velocity u in the same direction that the positive electricity flows there in element α' . Therefore this *electromotive force* is

$$= \pm \frac{k\alpha'u'}{\sqrt{2}} \cdot \frac{\mu \sin \varphi}{r^2}.$$

Here k denotes a constant factor independent of u' , whose value, however, has thus far not been more closely determined by any measurement.

If one denotes the angles, which in the one case the direction in which the positive electricity in element α' is moved, in the other case the direction in which the induced element α' itself is moved, form with three right-angled coordinate axes, as respectively

$$\lambda, \mu, \nu \text{ and } \beta, \gamma, \delta,$$

then under the just-presupposed identity of the directions specified,

$$\beta = \lambda, \gamma = \mu, \delta = \nu.$$

Here too, it is obvious that, under the presupposed identity of the two directions mentioned, the values of X', Y', Z' stated under (2) need only be multiplied by the constant factor ku'/i' in order to obtain the components $\bar{X}', \bar{Y}', \bar{Z}'$ of the electromotive force, which a *whole magnet* exerts on the induced element α' . From this it follows that

$$\begin{aligned}\bar{X}' &= -\frac{ku'}{\sqrt{2}} \cdot \alpha'(C' \cos \gamma - B' \cos \delta), \\ \bar{Y}' &= -\frac{ku'}{\sqrt{2}} \cdot \alpha'(A' \cos \delta - C' \cos \beta), \\ \bar{Z}' &= -\frac{ku'}{\sqrt{2}} \cdot \alpha'(B' \cos \beta - A' \cos \gamma),\end{aligned}$$

in which A', B', C' have the same signification as under (2).

The relations will now be examined between the laws set forth here and the empirical proposition mentioned in the beginning. Now, from the foregoing laws there results, when the *electrodynamic* forces stand to the *electromagnetic* forces in the ratio 1 : n , viz., when

$$\frac{X'}{X} = \frac{Y'}{Y} = \frac{Z'}{Z} = n$$

or, if for X, Y, Z , and X', Y', Z' , their values found above are substituted, when

$$\frac{C' \cos \mu - B' \cos \nu}{C \cos \mu - B \cos \nu} = \frac{A' \cos \nu - C' \cos \lambda}{A \cos \nu - C \cos \lambda} = \frac{B' \cos \lambda - A' \cos \mu}{B \cos \lambda - A \cos \mu} = \frac{i}{\sqrt{2}} \cdot n,$$

hence

$$A' = \frac{i}{\sqrt{2}} \cdot nA, \quad B' = \frac{i}{\sqrt{2}} \cdot nB, \quad C' = \frac{i}{\sqrt{2}} \cdot nC$$

the following relationship of the *electromotive* force obtained by means of *voltaic induction* and by means of *magnetic induction*:

$$\begin{aligned} \frac{\bar{X}'}{\bar{X}} &= \frac{k\sqrt{2}}{ai} \cdot \frac{C' \cos \gamma - B' \cos \delta}{C \cos \gamma - B \cos \delta} = \frac{k}{a} \cdot n, \\ \frac{\bar{Y}'}{\bar{Y}} &= \frac{k\sqrt{2}}{ai} \cdot \frac{A' \cos \delta - C' \cos \beta}{A \cos \delta - C \cos \beta} = \frac{k}{a} \cdot n, \\ \frac{\bar{Z}'}{\bar{Z}} &= \frac{k\sqrt{2}}{ai} \cdot \frac{B' \cos \beta - A' \cos \gamma}{B \cos \beta - A \cos \gamma} = \frac{k}{a} \cdot n. \end{aligned}$$

This, finally, yields the following result:

$$\frac{X'}{X} : \frac{\bar{X}'}{\bar{X}} = \frac{Y'}{Y} : \frac{\bar{Y}'}{\bar{Y}} = \frac{Z'}{Z} : \frac{\bar{Z}'}{\bar{Z}} = a : k,$$

which is in agreement with the empirical proposition mentioned at the beginning, because the ratio $a : k$ is *constant*. That empirical proposition, however, shows us still more than the comparison of the above laws, in that it makes this constant ratio equal to *unity*, by means of which the constant factor in the fundamental law of magnetic induction, k , a factor still undetermined by any measurement as yet, becomes equal to the constant factor a in the fundamental electrical law. Specifically, that would also have to take place, if there existed no magnetic fluid in the magnet, but, in accord with Ampère, all the effects of the magnets were produced by electrical currents in them.

26.

Comparison with the theorems established by Fechner and Neumann.

Fechner has been the first to attempt, by developing their intrinsic connection, an *explanation* of the Faraday phenomena of induction in terms of the Ampère electrodynamic phenomena, which Lenz previously put into relation with one another merely by means of an empirical rule; Fechner has published the explanation in *Poggendorff's Annalen*, 1845, Vol. LXIV, page 337. In so doing, Fechner has confined himself to that form of *voltaic induction*, with which the foregoing Section dealt, namely, to that by a constant current at rest in a conducting wire moving toward it. For this form of *voltaic induction*, Fechner has actually succeeded in discovering its *intrinsic connection* with Ampère's electrodynamic phenomena, and in basing an explanation of it on a somewhat *more generalized* form of Ampère's law which holds for the latter phenomena. – That *intrinsic connection* consists essentially in the fact that, with regard to that induction, apart

from the current first elicited by the induction, one is dealing, just as in the Ampère phenomena, with *reciprocal actions of electrical currents*, hence the explanation of both kinds of phenomena would have to rest on the laws of these reciprocal actions. The electricity in the induced conducting wire, Fechner says specifically, would also begin to flow, as soon as this conducting wire were *moved*, specifically because it participates in the motion of its carrier. The electrical currents in such induced conducting wires are only differentiated from the galvanic currents in the inducing wires in that equal masses of *positive* and *negative* electricity move simultaneously with the same velocity in *opposite* directions in the latter, in *the same* directions in the former. – The *generalization* which Fechner has given to Ampère's law, consists *first* in the fact that the force which, according to Ampère, acts on the ponderable carrier, would originally act with the same strength and in the same direction on the electrical masses located in the carrier, and would first be communicated from them to the carrier; *secondly*, in the fact that Ampère's law does not merely hold for the total action of a galvanic current on another, but also for the two partial actions, which the first current would exert on the *positive* and *negative* electricity of the second.

This explanation accords with the theory of this induction developed in the previous Section; for one finds there the justification of the right to generalize Ampère's law, on which that explanation is founded. This can be proven, if one considers in particular the two forces acting on the *positive* or *negative* electricity, as stated on page 99,⁵⁹ where one finds that Ampère's law holds not merely for all four forces, but also for any two of them.

Moreover, Fechner himself has already remarked that the standpoint from which he has interpreted the connection of Faraday's induction phenomena with the Ampère electrodynamic phenomena is not so general that it could be extended over all of Faraday's induction phenomena. As soon as the induced wire is *at rest*, the induction phenomena cannot be grasped from this standpoint, because then the motion of electricity in the induced wire is out of the question. On this point, Fechner says, loc. cit., page 341: “In the induction experiments, instead of moving the (neutral) wire *a'b'* away from the (excited) wire at rest, one could do the opposite, and the induction would always still occur. This must be accepted as an *empirical datum*, for proving that what matters here is simply the relation of the motions, and that it is permissible to substitute the converse for motion of the excited wire and rest in the neutral wire, in order to be able to apply the principle in the stated form.”

Neumann has based his investigation on the empirical rule by which Lenz linked the Faraday induction phenomena to the Ampère electrodynamic phenomena, and has found a supplement to it in the proposition, that the strength of the induction is proportional to the velocity of the motion of the induced wire, when the induction was elicited by a motion of the latter. These two empirical rules complement each other in such a way, that Neumann has been able to derive from them the *general laws of induced currents*, since the laws immediately following from them for the case in which the induction is elicited by a motion of the induced conductor, are of the kind that can immediately find application in wider domains without undergoing modification, and can be extended to all forms of induction. These *general laws of induced currents* admit of virtually no doubt, with respect to their intrinsic connection or also to the empirical rules implied in them, and for that reason it is interesting to compare the results of the theory developed above with these laws which Neumann derived in completely different ways.

Since Neumann's Treatise, submitted to the königliche Akademie der Wissenschaften in Berlin, has not yet been printed, I can only refer to the excerpt just now appearing in *Poggendorff's Annalen*, in this year's first issue, from which I take the following passage:

“§ 1. From Lenz's theorem that the action which the inducing current or magnet exerts on the induced conductor, always produces, when the induction is elicited by a motion of the latter, an

⁵⁹ [N. E.] Page 158 of Weber's *Werke*, Vol. 3.

inhibiting influence on this motion, conjointly with the theorem that the strength of the momentary induction is proportional to the velocity of this motion, is derived the general law of linear induction:

$$Eds = -\varepsilon v C ds .$$

Here ds signifies an element of the inducing wire, and Eds the electromotive force induced in the element ds ; v is the velocity, with which ds is moved, C is the action of the inductor on ds , resolved according to the direction in which ds is moved, this element being thought of as having the unit of current flowing through it. The magnitude ε , independent of the nature of the induced conductor, can be treated as a constant in the case of linear induction, but is a function of time, such that it very quickly decreases, when its argument has an appreciable value, and be treated as such in the case of surface induction and of induction in bodies."

From the theory developed above, has resulted the following expression, at the end of Section 24, for the *electromotor* force induced in element α' , in which u' denotes the velocity with which α' is moved:

$$-\frac{\alpha\alpha'}{r^2}i\left(\cos\varepsilon - \frac{3}{2}\cos\vartheta\cos\vartheta'\right)\cdot au'\cos\varphi .$$

This expression was the value, resolved in the direction of element α' , of the total separating force exerted by the inductor α in the direction of the connecting straight line r , from which, by elimination of the factor $\cos\varphi$, the total force is once more obtained. In Section 25 (3), this total force is compared with the *electrodynamic* force, determined by Ampère's law, which the inductor α would exert on element α' , when α' were parallel to the direction in which the element α' were moved for purposes of induction, and through which a current flowed in this direction, whose intensity were $= i'$. Namely, one obtains that total *electromotive* force exerted in the direction of the connecting straight line r by multiplying this *electrodynamic* force by the factor au'/i' . The above expression itself is obtained by multiplying the same force, *resolved in the direction of the induced element α'* , by the factor au'/i' . If, therefore, this electrodynamic force, resolved in the direction of the induced element α' , is denoted

$$i'\alpha'D ,$$

then the above expression is to be made

$$= -au'D\alpha' .$$

Here, u' and α' are to be written v and ds , in accordance with Neumann's notation; hence the theory developed above, yields the equation, in this notation:

$$Eds = -avDds ,$$

in which a denotes a constant factor independent of the nature of the induced conductor, like ε in Neumann's equation, because here it is a matter of linear induction. Both equations are thus in agreement with each other up to the factors C and D . These factors also have in common their ability, multiplied by ds , to express the *electrodynamic* force, resolved in a definite direction, which the inductor would exert on an element ds , thought of as located in the place through which the induced unit of current flows. Yet the two factors are differentiated from one another 1. by the direction, which the element ds , thought of as at the point of induction, would be given, and 2. through the direction in which the electrodynamic force exerted on this element is to be resolved. Specifically, these two directions are *exchanged* in Neumann's law.

Neumann's law would, as can be seen from this, *contradict* ours, if one wanted to apply it to an individual current element as inductor, because factors C and D would then have entirely different values. It is obvious, however, that Neumann's law, in accordance with its derivation, holds first of all not for that individual inducing current element, but only for a closed circuit or for a magnet as inductor, specifically because Lenz's theorem, from which it is derived, can, being experimentally based, hold merely for closed circuits and magnets. That *apparent contradiction*

now automatically dissolves, as soon as the application of Neumann's law is confined to closed circuits, interchangeable with magnets, as inductors, in which case the identity of factors C and D can then be proven in the following way.

According to Ampère, the three components X, Y, Z of that force which a closed circuit of intensity i , for which the position of the elements is defined by the coordinates x, y, z , exerts on any other current element ds' of current intensity i' , whose direction makes the angles λ, μ, ν with the coordinate axes, when the origin of the coordinates lies in the center of the element ds' , are

$$\begin{aligned} X &= -\frac{1}{2}ii'ds' \left(\cos \mu \cdot \int \frac{xdy - ydx}{r^3} - \cos \nu \cdot \int \frac{zdx - xdz}{r^3} \right) \\ Y &= -\frac{1}{2}ii'ds' \left(\cos \nu \cdot \int \frac{ydz - zdy}{r^3} - \cos \lambda \cdot \int \frac{xdy - ydx}{r^3} \right) \\ Z &= -\frac{1}{2}ii'ds' \left(\cos \lambda \cdot \int \frac{zdx - xdz}{r^3} - \cos \mu \cdot \int \frac{ydz - zdy}{r^3} \right). \end{aligned}$$

From this the values for the factors C and D can now be derived for closed circuits as inductors.

For, *first*, factor C in Neumann's law is obtained, if X_1, Y_1, Z_1 denote the values taken on by X, Y, Z when we make $i' = I$ and λ, μ, ν are the angles which the induced element forms with the coordinate axes. Namely, if α, β, γ are the angles which the direction in which the induced element is moved, forms with the three coordinate axes, then

$$Cds' = X_1 \cos \alpha + Y_1 \cos \beta + Z_1 \cos \gamma.$$

This expression is simplified, if a coordinate system is chosen in which the direction of the x axis coincides with the direction *in which the induced element is moved*. Namely, then

$$\cos \alpha = 1, \cos \beta = 0, \cos \gamma = 0,$$

hence

$$Cds' = X_1 = -\frac{1}{2}ids' \left(\cos \mu \int \frac{xdy - ydx}{r^3} - \cos \nu \int \frac{zdx - xdz}{r^3} \right).$$

Secondly, factor D is obtained, if the values assumed by X, Y, Z are denoted X', Y', Z' , when we make $i' = I$, and $\lambda = \alpha', \mu = \beta', \nu = \gamma'$, where α', β', γ' are the angles which the direction in which the induced element is moved, forms with the three coordinate axes (which would thus be identical with α, β, γ , if the same coordinate system were chosen). Namely, if, according to the present coordinate system, λ', μ', ν' are the angles which the induced element forms with the three coordinate axes (which would thus be identical with λ, μ, ν , if the present coordinate system were identical with the former one), then:

$$Dds' = X' \cos \lambda' + Y' \cos \mu' + Z' \cos \nu'.$$

This expression is simplified, if one chooses a different coordinate system, as earlier, namely, one in which the direction of the x -axis coincides with the direction *of the induced element itself*, because then

$$\cos \lambda' = 1, \cos \mu' = 0, \cos \nu' = 0$$

hence:

$$Dds' = X' = -\frac{1}{2}ids' \left(\cos \beta' \int \frac{xdy - ydx}{r^3} - \cos \gamma' \int \frac{zdx - xdz}{r^3} \right).$$

Now the two coordinate systems, namely, that in which the x -axis is parallel to the direction *in which the induced element is moved*, and that in which the x -axis is parallel to the direction *of the induced element itself*, can have in common the y -axis, if it is normal to both directions, that of the induced element and its motion. Assuming this, it will be the case that

$$\cos \mu = 0, \cos \beta' = 0, \cos \nu = \cos \gamma',$$

and since, moreover, it can be proven that

$$\int \frac{zdx - xdz}{r^3}$$

would have an equal value according to both coordinate systems, then

$$C = D,$$

which was to be proven. That $zdx - xdz$ would have the same value for all right-angled coordinate systems in which, as in the two above, the origin coincides with the y -axis, is evident from the fact

that $\frac{1}{2}(zdx - xdz)$ represents the area projected on a plane normal to the common axis y , which is

formed by the common coordinate-origin, and by the current element in question. The straight line r , which connects the current element in question with the induced element, has a value altogether independent of the coordinate system chosen. From this it results that the value of the quotient $(zdx - xdz)/r^3$ for the two coordinate systems employed above is always the same, hence also is

[equal] the value of the integral extended over the entire closed circuit $\int \frac{zdx - xdz}{r^3}$.

It follows from this that Neumann's law for the domain of phenomena to which, in virtue of its derivation, it refers, namely, where all inductors are either magnets or closed circuits, concurs with the law derived from the theory developed above, but that the application of Neumann's law outside that domain to non-closed circuits as inductors is not permitted.

27.

Law of excitation of a current in a conductor at rest, when a constant current element approaches or withdraws from it.

The law of *voltaic induction* for this case, where the induced conductor is at rest, and the inducing current element is in motion, can be derived just as it was for the first case, from the established fundamental electrical law. It is, however, not necessary to give this derivation, because a simple consideration shows that, for the second case, it would have to lead back to the same law as for the first.

Namely, the fundamental electrical law, from which all laws of *voltaic induction* are to be derived, makes the action of one electrical mass on another dependent merely upon their *relative* distance, velocity, and acceleration. These, however, remain unchanged by a *common* motion attributed to both masses; hence, the action of one electrical mass on another is also not changed by such a *common* motion. Consequently, such a *common* motion can be attributed to all electrical masses without changing their actions, hence also without changing the induction dependent upon them. Therefore, if one has an inducing current element α , which is in motion with the *absolute* velocity u' in any direction, while the induced element α' is at *absolute* rest, then, without changing the induction, one can attribute to both elements, along with the electrical masses contained in them, a *common* motion of velocity u' in that direction which is diametrically opposite to the direction in which current element α actually is in motion. By adding this common motion, the inducing element α is brought to rest, while now the induced element α' moves with the same velocity, but in the opposite direction, as the current element is actually moving. Therefore, from the established fundamental law, the same induction must result for the same *relative* motion of both elements, independently of whether, during this relative motion, one or the other or neither of

the two elements is at *absolute* rest. As is well known, empirical experience accords with this result.

28.

Law of excitation of a current in a conductor by changing the current intensity in an adjacent conductor.

If α and α' denote the lengths of the inducing and induced elements, then in two elements four electrical masses can be further distinguished:

$$+ \alpha e, - \alpha e, + \alpha' e', - \alpha' e'.$$

The *first* of these masses $+ \alpha e$ would move with the *variable* velocity u in the direction of the element at rest α , which makes the angle \mathcal{G} with the straight line drawn from α to α' , and du would denote the change in u during time-element dt ; the *second*, $- \alpha e$, would move, in accordance with the determinations relating to a galvanic current, in the same direction with velocity $-u$, viz. backwards, and $-du$ would denote the change in this velocity during time-element dt ; the *third*, $+ \alpha' e'$, would move with constant velocity $+u'$ in the direction of the element at rest α' , which makes the angle \mathcal{G}' with the straight line drawn and elongated from α to α' ; the *fourth*, $- \alpha' e'$, would, finally, move, again according to the determinations relating to a galvanic current, in the same direction with velocity $-u'$, viz., backwards. The distances of the first two masses from the second two are themselves all the same at the moment in question as distance r between the two elements α and α' ; since, however, they do not remain equal, they are to be denoted r_1, r_2, r_3, r_4 .

For the *sum* of the forces which are acting on the *positive* and *negative* electricity in element α' , i.e., for the force, which moves element α' itself, one obtains the same expression as in Section 24, namely:

$$-\frac{a^2}{16} \cdot \frac{\alpha e \cdot \alpha' e'}{r^2} \left\{ \left(\frac{dr_1^2}{dt^2} + \frac{dr_2^2}{dt^2} - \frac{dr_3^2}{dt^2} - \frac{dr_4^2}{dt^2} \right) - 2r \left(\frac{d^2 r_1}{dt^2} + \frac{d^2 r_2}{dt^2} - \frac{d^2 r_3}{dt^2} - \frac{d^2 r_4}{dt^2} \right) \right\}.$$

However, for the *difference* of those forces, on which the *induction* depends,

$$-\frac{a^2}{16} \cdot \frac{\alpha e \cdot \alpha' e'}{r^2} \left\{ \left(\frac{dr_1^2}{dt^2} - \frac{dr_2^2}{dt^2} + \frac{dr_3^2}{dt^2} - \frac{dr_4^2}{dt^2} \right) - 2r \left(\frac{d^2 r_1}{dt^2} - \frac{d^2 r_2}{dt^2} + \frac{d^2 r_3}{dt^2} - \frac{d^2 r_4}{dt^2} \right) \right\}.$$

Further, the same values hold here for the first differential coefficients as were found in Section 22, namely:

$$\begin{aligned} \frac{dr_1}{dt} &= -\frac{dr_2}{dt} = -u \cos \mathcal{G} + u' \cos \mathcal{G}', \\ \frac{dr_3}{dt} &= -\frac{dr_4}{dt} = -u \cos \mathcal{G} - u' \cos \mathcal{G}'. \end{aligned}$$

Hence

$$\begin{aligned} \left(\frac{dr_1^2}{dt^2} + \frac{dr_2^2}{dt^2} - \frac{dr_3^2}{dt^2} - \frac{dr_4^2}{dt^2} \right) &= -8uu' \cos \mathcal{G} \cos \mathcal{G}', \\ \left(\frac{dr_1^2}{dt^2} - \frac{dr_2^2}{dt^2} + \frac{dr_3^2}{dt^2} - \frac{dr_4^2}{dt^2} \right) &= 0. \end{aligned}$$

Since the velocity u is now variable, however, there result values for the second differential coefficients other than those in Section 22, where it was constant, namely:

$$\begin{aligned}\frac{d^2r_1}{dt^2} &= +u \sin \vartheta \cdot \frac{d\vartheta_1}{dt} - u' \sin \vartheta' \cdot \frac{d\vartheta'_1}{dt} - \cos \vartheta \cdot \frac{du}{dt}, \\ \frac{d^2r_2}{dt^2} &= -u \sin \vartheta \cdot \frac{d\vartheta_2}{dt} + u' \sin \vartheta' \cdot \frac{d\vartheta'_2}{dt} + \cos \vartheta \cdot \frac{du}{dt}, \\ \frac{d^2r_3}{dt^2} &= +u \sin \vartheta \cdot \frac{d\vartheta_3}{dt} + u' \sin \vartheta' \cdot \frac{d\vartheta'_3}{dt} - \cos \vartheta \cdot \frac{du}{dt}, \\ \frac{d^2r_4}{dt^2} &= -u \sin \vartheta \cdot \frac{d\vartheta_4}{dt} - u' \sin \vartheta' \cdot \frac{d\vartheta'_4}{dt} + \cos \vartheta \cdot \frac{du}{dt}.\end{aligned}$$

Therefore, there results for

$$\begin{aligned}\left(\frac{d^2r_1}{dt^2} + \frac{d^2r_2}{dt^2} - \frac{d^2r_3}{dt^2} - \frac{d^2r_4}{dt^2}\right) &= +u \sin \vartheta \left(\frac{d\vartheta_1}{dt} - \frac{d\vartheta_2}{dt} - \frac{d\vartheta_3}{dt} + \frac{d\vartheta_4}{dt}\right) \\ &- u' \sin \vartheta' \left(\frac{d\vartheta'_1}{dt} - \frac{d\vartheta'_2}{dt} + \frac{d\vartheta'_3}{dt} - \frac{d\vartheta'_4}{dt}\right)\end{aligned}$$

the same value as in Section 22, namely, when one substitutes the values of $d\vartheta_1/dt$, $d\vartheta'_1/dt$, and so forth, developed there on page 102,⁶⁰

$$r \left(\frac{d^2r_1}{dt^2} + \frac{d^2r_2}{dt^2} - \frac{d^2r_3}{dt^2} - \frac{d^2r_4}{dt^2}\right) = -8uu' \sin \vartheta \sin \vartheta' \cos \omega.$$

On the other hand,

$$\begin{aligned}\left(\frac{d^2r_1}{dt^2} - \frac{d^2r_2}{dt^2} + \frac{d^2r_3}{dt^2} - \frac{d^2r_4}{dt^2}\right) &= +u \sin \vartheta \left(\frac{d\vartheta_1}{dt} + \frac{d\vartheta_2}{dt} + \frac{d\vartheta_3}{dt} + \frac{d\vartheta_4}{dt}\right) \\ &- u' \sin \vartheta' \left(\frac{d\vartheta'_1}{dt} + \frac{d\vartheta'_2}{dt} - \frac{d\vartheta'_3}{dt} - \frac{d\vartheta'_4}{dt}\right) - 4 \cos \vartheta \cdot \frac{du}{dt}.\end{aligned}$$

Since, however, according to page 102,⁶¹ the values

$$\frac{d\vartheta_1}{dt} + \frac{d\vartheta_2}{dt} = \frac{d\vartheta_3}{dt} + \frac{d\vartheta_4}{dt} = \frac{d\vartheta'_1}{dt} + \frac{d\vartheta'_2}{dt} = \frac{d\vartheta'_3}{dt} + \frac{d\vartheta'_4}{dt} = 0$$

then

$$\left(\frac{d^2r_1}{dt^2} - \frac{d^2r_2}{dt^2} + \frac{d^2r_3}{dt^2} - \frac{d^2r_4}{dt^2}\right) = -4 \cos \vartheta \cdot \frac{du}{dt}.$$

If these values are substituted, one obtains the *sum* of the forces acting on the *positive* and *negative* electricity in element α' , as [in] Section 22

$$= -\frac{\alpha\alpha'}{r^2} \cdot aeu \cdot ae'u' \left(\sin \vartheta \sin \vartheta' \cos \omega - \frac{1}{2} \cos \vartheta \cos \vartheta'\right),$$

viz., the force acting on element α' is, when the current intensity is variable, determined just as it is when the current is constant, and Ampère's law is applicable to variable currents as well.

The *difference* between those two forces acting on the *positive* and *negative* electricity in element α' , on which the *induction* depends, results, on the other hand, as

$$= -\frac{1}{2} \frac{\alpha\alpha'}{r} \cdot a^2 ee' \cdot \cos \vartheta \cdot \frac{du}{dt},$$

or, since according to page 94,⁶² $aeu = i$, hence u is variable, and $ae \cdot du = di$,

⁶⁰ [N. E.] Page 162 of Weber's *Werke*, Vol. 3.

⁶¹ [N. E.] Page 162 of Weber's *Werke*, Vol. 3.

$$= -\frac{1}{2} \frac{\alpha\alpha'}{r} \cdot ae' \cdot \cos \vartheta \cdot \frac{di}{dt}.$$

The force determined in this way tries to separate the *positive* and *negative* electricities in the induced element α' in the direction of the straight line r . But in this direction the separation can not succeed, it can only happen in the direction of the induced element α' itself, which forms the angle ϑ' with the extended straight line r . Decomposing then this total force, which tries to separate both electricities in α' , along this direction, that is, multiplying the *difference* above with $\cos \vartheta'$, we obtain the force which produces the real separation,

$$= -\frac{1}{2} \frac{\alpha\alpha'}{r} \cdot ae' \cdot \cos \vartheta \cos \vartheta' \cdot \frac{di}{dt}.$$

If this value is divided by e' , there results the *electromotor* force, in the ordinary sense, exerted by the inducing element α on the induced element α' (see Section 24, page 109):⁶³

$$= -\frac{a}{2} \cdot \frac{\alpha\alpha'}{r} \cdot \cos \vartheta \cos \vartheta' \cdot \frac{di}{dt}.$$

The *induction* during the time element dt , viz., the product of this time element with the acting electromotive force, is therefore

$$= -\frac{a}{2} \cdot \frac{\alpha\alpha'}{r} \cdot \cos \vartheta \cos \vartheta' \cdot di,$$

hence the *induction* for any period of time, in which the intensity of the inducing current increases to i , while r , ϑ and ϑ' remain unchanged,

$$= -\frac{a}{2} \cdot \frac{\alpha\alpha'}{r} \cdot i \cos \vartheta \cos \vartheta'.$$

The *positive* value of this expression denotes an induced current in element α' in the direction of α' , which makes the angle ϑ' with the extended straight line r ; the *negative* value denotes an induced current of opposite direction.

If both elements α and α' are parallel to each other, and $\vartheta = \vartheta'$, the above expression has a *negative* value for *increasing* current intensity, or for a positive value of i , viz. when the current intensity increases in α , a current in the opposite direction from the inducing current is excited in α' . The reverse takes place when the current intensity decreases. Both results agree with known facts. The proportionality of the induction to the change in intensity i of the inducing current also corresponds to empirical experience, to the degree that estimates suffice without precise measurement.

29.

Comparison of induction effects of constant currents on a moving conductor with those of variable currents on conductors at rest.

In the previous Section, the laws of *voltaiic induction* have been derived from the fundamental electrical law, in agreement with empirical experience, not only for the case where the voltaic induction is elicited by *constant* currents in *moving* conductors, but also for the case, where it is elicited by *variable* currents in conductors *at rest*. The *laws of induction* for these two cases are very different, and on that account it is very interesting, that nevertheless they yield very simple relationships between the effects of both inductions.

⁶² [N. E.] Page 152 of Weber's *Werke*, Vol. 3.

⁶³ [N. E.] Page 170 of Weber's *Werke*, Vol. 3.

One such simple relationship between the induction effect of *constant* currents on a *moving* conductor and the induction effect of *variable* currents on a conductor at rest, results from the laws already developed in Sections 24 and 28 for individual inducing and induced *elements*, when the motion of the induced element occurs, in the first case, in the direction of the straight line r . For if one calculates under this assumption the total induction effect, which a current element of *constant* intensity i elicits, while the induced element is withdrawn from a given position infinitely far in the direction of the straight line r , or, from an infinite distance, approaches that position, then one finds that this total induction effect is equal to that which the inducing element would elicit, if its current intensity were to decrease or increase by i , in the induced element, if it continued in the given position. Therefore this yields the rule, for this special case, to begin with, *that, by means of the appearance or disappearance of a current in the proximity of a conductor, the same current would be induced in this conductor, as if that current would have uniformly persisted, but were either transferred from a great distance into that proximity to the conductor, or, conversely, transferred from that proximity to a great distance.*

For the cited special case, this theorem easily results, as follows. The expression found at the end of Section 24 for the electromotor force is to be multiplied by the time element dt , in order to obtain the *induction effect* corresponding to this time element dt , or corresponding to the element of displacement $u'dt$ traversed during this time element. The value of the integral of this product between definite time or displacement limits then yields the total *induction effect* corresponding to the time interval or to the displacement traversed in that time interval

$$= -ai \int \frac{\alpha\alpha'}{r^2} \left(\cos \varepsilon - \frac{3}{2} \cos \vartheta \cos \vartheta' \right) \cos \varphi \cdot u' dt .$$

In our case, where the motion occurs in the straight line r , now

$$u'dt = dr, \text{ and } \cos \vartheta' = 1 .$$

According to Section 24, $\cos \varepsilon = \sin \vartheta \sin \vartheta' \cos \omega + \cos \vartheta \cos \vartheta'$, therefore here:

$$\cos \varepsilon = \cos \vartheta .$$

Since, finally, the angles ϑ and φ have constant values during the motion in the direction of straight line r of the element α' constantly parallel to itself, that *induction effect* is

$$= + \frac{ai}{2} \cdot \alpha\alpha' \cos \vartheta \cos \varphi \cdot \int \frac{dr}{r^2} .$$

The value of this integral between the limits $r = r$ to $r = \infty$, viz. the *induction effect*, while the induced element is infinitely distant from a given position, is

$$= + \frac{ai}{2} \frac{\alpha\alpha'}{r} \cos \vartheta \cos \varphi ;$$

between the limits $r = \infty$ to $r = r$, viz. the *induction effect*, while the induced element, from an infinite distance, *reaches* a given position, is, on the contrary,

$$= - \frac{ai}{2} \frac{\alpha\alpha'}{r} \cos \vartheta \cos \varphi .$$

If it is taken into consideration that φ denotes here, in accordance with Section 24, the same angle which is ϑ' in Section 28, namely, the angle which the induced element α' makes with the prolonged straight line r , then it is seen that the induction effect is equal to that which, according to the law given in Section 28, is obtained when the induced element α' persists in the given position, and the current intensity i in the inducing element α vanishes or arises.

The relation found for both induction effects can be expressed more generally, not, of course, for individual elements, but for *closed currents and conductors*. The case may first of all be considered, where all elements of the induced closed conductor have the same, parallel, motion.

The *induction effect* of current element α on the induced element α' is, as before,

$$= -ai \int \frac{\alpha\alpha'}{r^2} \left(\cos \varepsilon - \frac{3}{2} \cos \vartheta \cos \vartheta' \right) \cos \varphi \cdot u' dt .$$

If β and β' now denote the angle, which the two elements α and α' make with the plane produced by the straight line r by the motion of the element α' , and further, if γ and γ' denote the angle, which the projections of α and α' make in the plane with the direction of the motion, then

$$\cos \vartheta = \cos \beta \cos(\vartheta' - \gamma),$$

$$\cos \varphi = \cos \beta' \cos(\vartheta' - \gamma'),$$

$$\cos \varepsilon = \cos \beta \cos \gamma .$$

The projection of the displacement element $u' dt$ on the straight line r yields the value of dr for the time-element dt ,

$$dr = u' dt \cdot \cos \vartheta' \quad \text{or} \quad u' dt = \sec \vartheta' \cdot dr .$$

If these values are substituted, the *induction effect* of α on α' becomes

$$= - \int ai \alpha \alpha' \cos \beta \cos \beta' \left(\cos \gamma \sec \vartheta' - \frac{3}{2} \cos(\vartheta' - \gamma) \right) \cos(\vartheta' - \gamma') \cdot \frac{dr}{r^2} ,$$

or, when $\cos(\vartheta' - \gamma)$ and $\cos(\vartheta' - \gamma')$ are developed,

$$= + \frac{ai}{2} \int \alpha \alpha' \cos \beta \cos \beta' \cdot dR ,$$

in which, for the sake of brevity, the following expression is denoted by dR :

$$\left(\cos \gamma \cos \gamma' - 2 \cos \gamma \sin \gamma' \tan \vartheta' - 3 \cos(\gamma + \gamma') \sin^2 \vartheta' + 3 \sin(\gamma + \gamma') \sin \vartheta' \cos \vartheta' \right) \cdot \frac{dr}{r^2} .$$

If it is taken into consideration, that in the like and parallel motion of all elements, each of them is displaced *parallel with itself*, hence the angles β , β' , γ , γ' are constant, and if one makes

$$\sin \vartheta' = \frac{b}{r}, \quad \cos \vartheta' = \frac{\sqrt{r^2 - b^2}}{r}, \quad \tan \vartheta' = \frac{b}{\sqrt{r^2 - b^2}},$$

in which b denotes the perpendicular from α to the path of induced element α' , then the integration can be carried out, and the following expression is obtained as an *indefinite integral*:

$$- \frac{ai}{2} \frac{\alpha \alpha'}{r} \cos \vartheta \cos \varphi - \frac{ai}{2} \frac{\alpha \alpha'}{r} \cos \beta \cos \beta' \sin(\gamma' - \gamma) \cot \vartheta' .$$

The sought-for *induction effect* is the *definite integral* or the difference between the two values, which the expression receives, when the two limiting values for r , ϑ , φ , and ϑ' are substituted in it.

If the same expression as that for elements α and α' is formed for *all* combinations of inducing and induced elements, which are contained in the closed circuit and conductor, and if the *summation* of all of them is denoted

$$- \frac{ai}{2} \mathbf{S} \frac{\alpha \alpha'}{r} \cos \vartheta \cos \varphi - \frac{ai}{2} \mathbf{S} \frac{\alpha \alpha'}{r} \cos \beta \cos \beta' \sin(\gamma' - \gamma) \cot \vartheta' ,$$

then the induction effect of the closed circuit on the closed conductor is equal to the difference between the two values, which this summation receives, when the values for r , ϑ , φ and ϑ' , corresponding to those at the beginning and end of the induction, are substituted in it.

Now, the above *summation* consists of two terms, and it will be proven, that the *latter term* is null for all values of r and ϑ' . Then the *induction effect* of a *closed* circuit on a *closed* conductor reduces itself to the difference between the two values, which the *first term* of the above summation assumes, when the values for r , ϑ , φ , corresponding to the beginning and end of the induction are substituted in it.

That the *latter term* of the above summation is, namely,

$$-\frac{ai}{2} \mathbf{S} \frac{\alpha\alpha'}{r} \cos \beta \cos \beta' \sin(\gamma'-\gamma) \cot \mathcal{G}' = 0$$

can easily be proven, if one analyzes the inducing and induced elements according to the law that, for determining the interaction of two elements, for any one of them, three others can be put in, which form the three edges of a parallelepiped, whose diagonal is taken up by the given elements. On this theorem, see Section 31 below.

Accordingly, if the elements α and α' are each decomposed into three elements, of which the *first* would be parallel to the direction of the motion, the *second* perpendicular to r , in the plane produced by r when α' is in motion, the *third* perpendicular to the two others, and if they are denoted

$$\alpha_1, \alpha_2, \alpha_3, \quad \text{and} \quad \alpha'_1, \alpha'_2, \alpha'_3,$$

then $[\alpha\alpha'/r] \cdot \cos \beta \cos \beta' \sin(\gamma'-\gamma) \cot \mathcal{G}'$ becomes a summation of 9 terms. For the two terms proportional to $\alpha_3\alpha'_1$ and to $\alpha_3\alpha'_2$, the factor is $\cos \beta = 0$; for the two terms proportional to $\alpha_1\alpha'_3$ and to $\alpha_2\alpha'_3$, the factor is $\cos \beta' = 0$; for the term proportional to $\alpha_3\alpha'_3$ the two factors are $\cos \beta = \cos \beta' = 0$; finally, for the 6th and 7th terms, which are proportional to $\alpha_1\alpha'_1$ and to $\alpha_2\alpha'_1$, the factor is $\sin(\gamma'-\gamma) = 0$. Hence there remain only two more terms, namely, those proportional to $\alpha_1\alpha'_2$ and to $\alpha_2\alpha'_1$, for which $\cos \beta = 1$, $\cos \beta' = 1$, $\sin(\gamma'-\gamma) = \mp \cos \mathcal{G}'$; these two terms are thus:

$$+\frac{ai}{2} \cdot \frac{\alpha_1\alpha'_2}{r} \cos \mathcal{G}' \cot \mathcal{G}' \quad \text{and} \quad \pm \frac{ai}{2} \cdot \frac{\alpha_2\alpha'_1}{r} \cos \mathcal{G}' \cot \mathcal{G}',$$

and for the sake of brevity, may be denoted A and B . If one now proceeds in like manner with each two elements of the closed circuit and conductor, then one finds that, among the remaining terms formed in just this way, two terms exist, by which A and B are cancelled, and which are to be denoted A' and B' . If this holds true in general, then it follows that

$$-\frac{ai}{2} \mathbf{S} \frac{\alpha\alpha'}{r} \cos \beta \cos \beta' \sin(\gamma'-\gamma) \cot \mathcal{G}' = 0,$$

which was to be proven.

Now, the element A' , by which A was cancelled, is found in the following way. Through the center of the *inducing* element α as apex, let two cones be put, whose common axis would be parallel to the direction of motion, i.e., to α_1 . Let these two cones delimit the *induced* element α' . It is evident, that at least a *second* element $\bar{\alpha}'$ of the *closed circuit* would still have to be delimited. And specifically, a current, which goes into α' *from the outer cone to the inner*, must go into $\bar{\alpha}'$ *conversely from the inner to the outer*. The value of \mathcal{G}' is the same for both elements. If one now decomposes the second element $\bar{\alpha}'$ in just the same way as the first α' , and denotes as $\bar{\alpha}'_2$ that lateral element which, perpendicular to the r' connecting $\bar{\alpha}'$ with α , lies in the plane produced by r' by the motion of $\bar{\alpha}'$, then the term proportional to $\alpha_1\bar{\alpha}'_2$ will be the term A' , by means of which A is cancelled. However,

$$A' = \mp \frac{ai}{2} \cdot \frac{\alpha_1\bar{\alpha}'_2}{r'} \cdot \cos \mathcal{G}' \cot \mathcal{G}',$$

and $\alpha'_2 : \bar{\alpha}'_2$ are in the ratio of their distances from the common apex of the two cones, i.e., the ratio $r : r'$, hence

$$\frac{\bar{\alpha}'_2}{r'} = \frac{\alpha'_2}{r}.$$

If these values are substituted, then

$$A' = \mp \frac{ai}{2} \frac{\alpha_1 \alpha'_2}{r} \cdot \cos \mathcal{G}' \cot \mathcal{G}',$$

and is, irrespective of the sign, equal to the value of A . From the *opposite direction* in which, as stated above, the elements α' and $\bar{\alpha}'$, or α'_2 and $\bar{\alpha}'_2$, have the same current flowing through them, it can be easily recognized, that if in A , $\sin(\gamma' - \gamma) = \mp \cos \mathcal{G}'$, and in A' , $\sin(\gamma' - \gamma) = \pm \cos \mathcal{G}'$, that therefore the values of A and A' always have opposite signs; hence the two cancel each other out.

It can occur, that in addition to α' and $\bar{\alpha}'$, yet a *third* element of the conductor is defined by the same cones; then, however, there must necessarily exist, if the conductor is *closed*, yet a *fourth* as well, and the same is true of the third and fourth as of the first and second, and so forth.

In a similar way, B' , which cancels B , is found, when the center of the *induced* element α' is made the apex of two cones, whose common axis is parallel to the direction of the motion, and which delimit the *inducing* element α . The same cones then delimit, from the *closed inductor*, yet a second element, from whose decomposition B' results, as A' did previously from the decomposition/analysis of element $\bar{\alpha}'$.

From the mutual cancellation of all terms denoted A , A' , B , B' , and so forth, it now follows that for *closed currents and conductors*, the equation is valid:

$$-\frac{ai}{2} \mathbf{S} \frac{\alpha \alpha'}{r} \cos \beta \cos \beta' \sin(\gamma' - \gamma) \cot \mathcal{G}' = 0.$$

Now, from this it follows, *first*, when a closed conductor with all its parts is moved identically and parallel *always in the same direction*, the *induction effect* is

$$= \frac{ai}{2} \mathbf{S} \frac{\alpha \alpha'}{r_0} \cos \mathcal{G}_0 \cos \varphi_0 - \frac{ai}{2} \mathbf{S} \frac{\alpha \alpha'}{r_1} \cos \mathcal{G}_1 \cos \varphi_1,$$

in which the values of r , \mathcal{G} , φ are denoted r_0 , \mathcal{G}_0 , φ_0 for the beginning of the induction, and r_1 , \mathcal{G}_1 , φ_1 for the end. If one makes $r_1 = \infty$, viz. the closed conductor, from a given position, is removed infinitely far distant from the inducing current, then the total induction effect elicited thereby is

$$= \frac{ai}{2} \mathbf{S} \frac{\alpha \alpha'}{r_0} \cos \mathcal{G}_0 \cos \varphi_0,$$

the same, which results, according to the preceding Section, for the same *inducing* current conductor and for the same *induced* conductor, when they *persist* in their initial mutual positions and the current i *vanishes* in the former.

Secondly, when a closed conductor with all its parts is only slightly displaced identically and parallel in any definite direction, and then displaced again in a somewhat *changed* direction, and so forth, and when the values of r , \mathcal{G} , φ are denoted r_0 , \mathcal{G}_0 , φ_0 at the start of the induction, at the end of the first or beginning of the second displacement are denoted r_1 , \mathcal{G}_1 , φ_1 , at the end of the second or beginning of the third displacement r_2 , \mathcal{G}_2 , φ_2 , and so forth, it follows that the total *induction effect* is

$$\begin{aligned} &= + \frac{ai}{2} \mathbf{S} \frac{\alpha \alpha'}{r_0} \cos \mathcal{G}_0 \cos \varphi_0 - \frac{ai}{2} \mathbf{S} \frac{\alpha \alpha'}{r_1} \cos \mathcal{G}_1 \cos \varphi_1 \\ &+ \frac{ai}{2} \mathbf{S} \frac{\alpha \alpha'}{r_1} \cos \mathcal{G}_1 \cos \varphi_1 - \frac{ai}{2} \mathbf{S} \frac{\alpha \alpha'}{r_2} \cos \mathcal{G}_2 \cos \varphi_2 \\ &+ \text{and so forth.} \end{aligned}$$

If r_n , \mathcal{G}_n , φ_n denote the values of r , \mathcal{G} , φ at the end of all these motions effected successively in *different* directions, then, because all terms with the exception of the first and last cancel each other out, the indicated value of the total induction effect reduces itself to

$$\frac{ai}{2} \mathbf{S} \frac{\alpha\alpha'}{r_0} \cos \mathcal{G}_0 \cos \varphi_0 - \frac{ai}{2} \mathbf{S} \frac{\alpha\alpha'}{r_n} \cos \mathcal{G}_n \cos \varphi_n,$$

from which one sees, when $r_n = \infty$, that the *induction effect* is the same, when a closed conductor is removed, from a given position with respect to a closed current, infinitely far from the inducing current through an arbitrarily *curved* trajectory, but in such a way that all parts always remain parallel to each other, as if the same thing would occur through a *straight* trajectory, or as if the closed conductor would *persist* in its original position and the current i in the inducing conductor would *vanish*, namely

$$= \frac{ai}{2} \mathbf{S} \frac{\alpha\alpha'}{r_0} \cos \mathcal{G}_0 \cos \varphi_0.$$

If, *thirdly* and finally, the closed conductor moves with complete arbitrariness, then the motion of any one of its elements at any moment can be resolved into a *rotation* around its center, and into a parallel *displacement* of the whole element. The induction effect of the *rotation* of an element around its center is = 0, because r remains unchanged thereby, hence $dr = 0$. The *displacement* of each element can be decomposed into three displacements in the directions of three coordinate axes. For the parallel displacement of all elements of the closed conductor in *any* of these directions, then,

$$\mathbf{S} \frac{\alpha\alpha'}{r} \cos \beta \cos \beta' \sin(\gamma' - \gamma) \cos \mathcal{G}' = 0,$$

from which it can easily be seen that even in *arbitrary motion* of the closed conductor, it follows that the *induction effect*

$$= \frac{ai}{2} \mathbf{S} \frac{\alpha\alpha'}{r_0} \cos \mathcal{G}_0 \cos \varphi_0 - \frac{ai}{2} \mathbf{S} \frac{\alpha\alpha'}{r_n} \cos \mathcal{G}_n \cos \varphi_n$$

in which r_0 , \mathcal{G}_0 , φ_0 and r_n , \mathcal{G}_n , φ_n denote the values of r , \mathcal{G} , φ at the beginning and end of the induction.

The relationship discussed here between the induction effect of a closed *constant* current on a closed conductor *in motion*, and between the induction effect of a closed *variable* current on a closed conductor *at rest*, has already been presented with greater generality by Neumann, loc. cit. Namely, Neumann bases on the *empirical* foundation cited in Section 26, the conclusion that the total induction effect corresponding to the transference of the induced conductor from one position to another, is independent of the intermediate positions, which it passes through, and merely depends upon the difference in the *potential values* of the inductor at the start and end of the trajectory. After Neumann has stated this theorem for the induction effect of *constant* currents on *moving* conductors, he continues on page 39, loc. cit.: "From the independence of the induced electromotor force from the motion per se, it is inferred, that *any cause*, which elicits a change in the value of the *potential* of a closed current with respect to a closed conductor, induces a current, whose electromotor force is expressed by means of the *change* which the *potential* has undergone." With the help of this theorem, Neumann has reduced the determination of the second kind of *voltaic induction*, namely, that of a *variable* current on a conductor at rest, to that of the first kind, namely, of a *constant* current on a conductor *in motion*. The above-mentioned relationship between both induction effects follows self-evidently. The final basis of all these relationships can now be directly proven according to the above, in the *fundamental electrical law*, according to which every two electrical masses act on each other at a distance.

General Law of Volta-induction.

After considering the two main cases of *voltaic induction*, namely, where either the current is *constant*, but the conductor is *in motion*, or where the current is *variable*, but the conductor is *unmoved*, the general law of determination of the effects of *arbitrarily moving currents through which a current passes according to the laws of galvanism* can easily be developed.

α and α' denote once again the lengths of two elements, of which the first, α , is assumed to be *at rest*. In accordance with Section 27, this assumption does not restrict the generality of the treatment, because each motion of element α can be carried over to α' , by attributing to it the opposite direction in α' . In these two elements, as earlier, the following four electrical masses are distinguished:

$$+ae, -ae, +\alpha'e', -\alpha'e'.$$

The *first* of these masses, $+ae$, would move with velocity $+u$ in the direction of the element at rest α , which makes the angle ϑ with the straight line drawn from α to α' . This velocity would change during time-element dt by $+du$. The *second* mass $-ae$, in conformity with the determinations given for a galvanic current, would move in the same direction, with velocity $-u$, viz., backwards, and this velocity would change during time-element dt by $-du$. The *third* mass $+\alpha'e'$ would move with velocity $+u'$ in the direction of element α' , which makes the angle ϑ' with the straight line drawn and extended from α to α' . This velocity changes in time-element dt by $+du'$. However, this electrical mass also shares the motion of element α' itself, which occurs with velocity v in a direction which makes the angle η with the straight line drawn and extended from α to α' , and is contained in a plane laid through this straight line, which forms the angle \aleph with the plane laid through the same straight line parallel to element α . Velocity v would change during the time-element dt by dv . The *fourth* mass $-\alpha'e'$ would move, in conformity with the determinations for a galvanic current, in the same direction as element α' with velocity $-u'$, which changes in time-element dt by $-du'$; additionally, however, it would share with the preceding mass the velocity v of element α' itself in the already signified direction. The distances of the two former masses from the two latter ones are all, at the moment in question, equal to the distance r of the two elements themselves; however, since they do not remain equal, they are to be denoted r_1, r_2, r_3, r_4 . If two planes are laid through the straight line drawn from α to α' , the one parallel to α , the other with α' , then ω denotes the angle formed by these two planes.

For the *sum* of the forces which act on the *positive* and *negative* electricity in element α' , that is, for the force, which moves element α' itself, one then obtains the same expression as in Section 24, namely:

$$-\frac{a^2}{16} \cdot \frac{\alpha e \cdot \alpha' e'}{r^2} \left\{ \left(\frac{dr_1^2}{dt^2} + \frac{dr_2^2}{dt^2} - \frac{dr_3^2}{dt^2} - \frac{dr_4^2}{dt^2} \right) - 2r \left(\frac{d^2 r_1}{dt^2} + \frac{d^2 r_2}{dt^2} - \frac{d^2 r_3}{dt^2} - \frac{d^2 r_4}{dt^2} \right) \right\}.$$

for the *difference* of those forces, however, on which *induction* depends,

$$-\frac{a^2}{16} \cdot \frac{\alpha e \cdot \alpha' e'}{r^2} \left\{ \left(\frac{dr_1^2}{dt^2} - \frac{dr_2^2}{dt^2} + \frac{dr_3^2}{dt^2} - \frac{dr_4^2}{dt^2} \right) - 2r \left(\frac{d^2 r_1}{dt^2} - \frac{d^2 r_2}{dt^2} + \frac{d^2 r_3}{dt^2} - \frac{d^2 r_4}{dt^2} \right) \right\}.$$

Further, when, along with the motion of the electrical masses in their conductors, one also takes into calculation the motion they share with their conductors, the first differential coefficients are found in the way presented in Section 22, by adding to the values found there the velocity of element α' , resolved in the direction of straight line r . One then obtains:

$$\begin{aligned}\frac{dr_1}{dt} &= -u \cos \vartheta + u' \cos \vartheta' + v \cos \eta \\ \frac{dr_2}{dt} &= +u \cos \vartheta - u' \cos \vartheta' + v \cos \eta \\ \frac{dr_3}{dt} &= -u \cos \vartheta - u' \cos \vartheta' + v \cos \eta \\ \frac{dr_4}{dt} &= +u \cos \vartheta + u' \cos \vartheta' + v \cos \eta.\end{aligned}$$

Therefore:

$$\begin{aligned}\left(\frac{dr_1^2}{dt^2} + \frac{dr_2^2}{dt^2} - \frac{dr_3^2}{dt^2} - \frac{dr_4^2}{dt^2}\right) &= -8uu' \cos \vartheta \cos \vartheta', \\ \left(\frac{dr_1^2}{dt^2} - \frac{dr_2^2}{dt^2} + \frac{dr_3^2}{dt^2} - \frac{dr_4^2}{dt^2}\right) &= -8uv \cos \vartheta \cos \eta.\end{aligned}$$

The second differential coefficient is obtained as in Section 22, when, in addition, the variability of velocities u , u' , v is considered, namely:

$$\begin{aligned}\frac{d^2 r_1}{dt^2} &= +u \sin \vartheta \cdot \frac{d\vartheta}{dt} - u' \sin \vartheta' \cdot \frac{d\vartheta'}{dt} - v \sin \eta \frac{d\eta}{dt} - \cos \vartheta \frac{du}{dt} + \cos \vartheta' \frac{du'}{dt} + \cos \eta \frac{dv}{dt} \\ \frac{d^2 r_2}{dt^2} &= -u \sin \vartheta \cdot \frac{d\vartheta}{dt} + u' \sin \vartheta' \cdot \frac{d\vartheta'}{dt} - v \sin \eta \frac{d\eta}{dt} + \cos \vartheta \frac{du}{dt} - \cos \vartheta' \frac{du'}{dt} + \cos \eta \frac{dv}{dt} \\ \frac{d^2 r_3}{dt^2} &= +u \sin \vartheta \cdot \frac{d\vartheta}{dt} + u' \sin \vartheta' \cdot \frac{d\vartheta'}{dt} - v \sin \eta \frac{d\eta}{dt} - \cos \vartheta \frac{du}{dt} - \cos \vartheta' \frac{du'}{dt} + \cos \eta \frac{dv}{dt} \\ \frac{d^2 r_4}{dt^2} &= -u \sin \vartheta \cdot \frac{d\vartheta}{dt} - u' \sin \vartheta' \cdot \frac{d\vartheta'}{dt} - v \sin \eta \frac{d\eta}{dt} + \cos \vartheta \frac{du}{dt} + \cos \vartheta' \frac{du'}{dt} + \cos \eta \frac{dv}{dt}.\end{aligned}$$

Hence

$$\begin{aligned}\left(\frac{d^2 r_1}{dt^2} + \frac{d^2 r_2}{dt^2} - \frac{d^2 r_3}{dt^2} - \frac{d^2 r_4}{dt^2}\right) &= +u \sin \vartheta \left(\frac{d\vartheta}{dt} - \frac{d\vartheta_2}{dt} - \frac{d\vartheta_3}{dt} + \frac{d\vartheta_4}{dt}\right) \\ &- u' \sin \vartheta' \left(\frac{d\vartheta'_1}{dt} - \frac{d\vartheta'_2}{dt} + \frac{d\vartheta'_3}{dt} - \frac{d\vartheta'_4}{dt}\right) - v \sin \eta \left(\frac{d\eta_1}{dt} + \frac{d\eta_2}{dt} - \frac{d\eta_3}{dt} - \frac{d\eta_4}{dt}\right)\end{aligned}$$

and

$$\begin{aligned}\left(\frac{d^2 r_1}{dt^2} - \frac{d^2 r_2}{dt^2} + \frac{d^2 r_3}{dt^2} - \frac{d^2 r_4}{dt^2}\right) &= +u \sin \vartheta \left(\frac{d\vartheta}{dt} + \frac{d\vartheta_2}{dt} + \frac{d\vartheta_3}{dt} + \frac{d\vartheta_4}{dt}\right) \\ &- u' \sin \vartheta' \left(\frac{d\vartheta'_1}{dt} + \frac{d\vartheta'_2}{dt} - \frac{d\vartheta'_3}{dt} - \frac{d\vartheta'_4}{dt}\right) - v \sin \eta \left(\frac{d\eta_1}{dt} - \frac{d\eta_2}{dt} + \frac{d\eta_3}{dt} - \frac{d\eta_4}{dt}\right) \\ &- 4 \cos \vartheta \cdot \frac{du}{dt}.\end{aligned}$$

For the determination of the differential coefficients $d\vartheta/dt$, $d\vartheta'/dt$, $d\eta/dt$, and so forth, one now proceeds as on page 100 ff.⁶⁴ or as in the footnote on page 102.⁶⁵ Namely, the resulting changes in the direction of straight line r_1

⁶⁴ [N. E.] Page 159 ff. of Weber's *Werke*, Vol. 3.

⁶⁵ [N. E.] Page 162 of Weber's *Werke*, Vol. 3.

in the plane of angle $\vartheta = +\frac{udt}{r_1} \cdot \sin \vartheta$

in the plane of angle $\vartheta' = -\frac{u'dt}{r_1} \cdot \sin \vartheta'$

in the plane of angle $\eta = -\frac{vdt}{r_1} \cdot \sin \eta$.

If one now draws lines parallel to line r , and with the directionalities of velocities u , u' and v , through the center of a sphere, which cut the surface (Figure 21) at R , U , U' , and V , and connects R with U , U' and V through the greatest arcs, then the plane containing the arc $UR = \vartheta$, forms the angle designated ω , with the plane of the arc $U'R = \vartheta'$, and forms the angle designated \aleph with the plane of the arc $VR = \eta$.

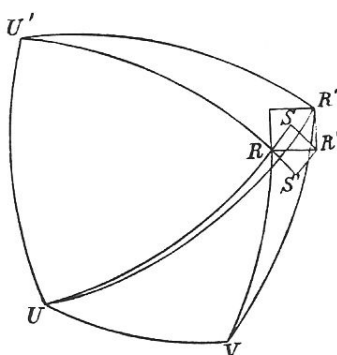

Fig. 21.

Let the arc UR be extended to S , $U'R$ to S' , and VR to T , and let

$$RS = +\frac{udt}{r_1} \sin \vartheta, \quad RS' = -\frac{u'dt}{r_1} \sin \vartheta', \quad RT = -\frac{vdt}{r_1} \sin \eta.$$

The element of the sphere's surface in which R , S , S' and T lie, can now, as on page 102,⁶⁶ be considered as an element of the plane touching the sphere at R , and the arc elements RS , RS' and RT as straight lines in this plane. If the parallelogram $RSR'S'$ is completed in this plane, the diagonal RR' is drawn, and the second parallelogram $RR'R''T$ is completed, then a line drawn through the center parallel to straight line r_1 , which connects the two *positive* masses $+\alpha e$ and $+\alpha'e'$ at the end of time element dt , goes through point R'' .

Finally, if R'' is connected with U , U' and V by the greatest arc, then

$$\begin{aligned} UR'' &= \vartheta + d\vartheta_1 = UR + d\vartheta_1 \\ U'R'' &= \vartheta' + d\vartheta'_1 = U'R + d\vartheta'_1 \\ VR'' &= \eta + d\eta' = VR + d\eta_1. \end{aligned}$$

From this follows that

$$\begin{aligned} d\vartheta_1 &= UR'' - UR = RS + RS' \cos \omega + RT \cos \aleph \\ d\vartheta'_1 &= U'R'' - U'R = RS' + RS \cos \omega + RT \cos(\omega + \aleph) \\ d\eta_1 &= VR'' - VR = RT + RS \cos \aleph + RS' \cos(\omega + \aleph). \end{aligned}$$

If the values presented above of RS , RS' and RT are substituted, then one obtains:

⁶⁶ [N. E.] Page 161 of Weber's *Werke*, Vol. 3.

$$\begin{aligned}
r_1 \frac{d\mathcal{G}_1}{dt} &= +u \sin \mathcal{G} - u' \sin \mathcal{G}' \cos \omega - v \sin \eta \cos \aleph \\
r_1 \frac{d\mathcal{G}'_1}{dt} &= -u' \sin \mathcal{G}' + u \sin \mathcal{G} \cos \omega - v \sin \eta \cos(\omega + \aleph) \\
r_1 \frac{d\eta_1}{dt} &= -v \sin \eta + u \sin \mathcal{G} \cos \aleph - u' \sin \mathcal{G}' \cos(\omega + \aleph).
\end{aligned}$$

In the same way, the result for the two *negative* masses $-\alpha e$ and $-\alpha' e'$ is:

$$\begin{aligned}
r_2 \frac{d\mathcal{G}_2}{dt} &= -u \sin \mathcal{G} + u' \sin \mathcal{G}' \cos \omega - v \sin \eta \cos \aleph \\
r_2 \frac{d\mathcal{G}'_2}{dt} &= +u' \sin \mathcal{G}' - u \sin \mathcal{G} \cos \omega - v \sin \eta \cos(\omega + \aleph) \\
r_2 \frac{d\eta_2}{dt} &= -v \sin \eta - u \sin \mathcal{G} \cos \aleph + u' \sin \mathcal{G}' \cos(\omega + \aleph);
\end{aligned}$$

further for the *positive* mass $+\alpha e$ and for the *negative* mass $-\alpha' e'$:

$$\begin{aligned}
r_3 \frac{d\mathcal{G}_3}{dt} &= +u \sin \mathcal{G} + u' \sin \mathcal{G}' \cos \omega - v \sin \eta \cos \aleph \\
r_3 \frac{d\mathcal{G}'_3}{dt} &= +u' \sin \mathcal{G}' + u \sin \mathcal{G} \cos \omega - v \sin \eta \cos(\omega + \aleph) \\
r_3 \frac{d\eta_3}{dt} &= -v \sin \eta + u \sin \mathcal{G} \cos \aleph + u' \sin \mathcal{G}' \cos(\omega + \aleph);
\end{aligned}$$

finally, for the *negative* $-\alpha e$ and for the *positive* $+\alpha' e'$:

$$\begin{aligned}
r_4 \frac{d\mathcal{G}_4}{dt} &= -u \sin \mathcal{G} - u' \sin \mathcal{G}' \cos \omega - v \sin \eta \cos \aleph \\
r_4 \frac{d\mathcal{G}'_4}{dt} &= -u' \sin \mathcal{G}' - u \sin \mathcal{G} \cos \omega - v \sin \eta \cos(\omega + \aleph) \\
r_4 \frac{d\eta_4}{dt} &= -v \sin \eta - u \sin \mathcal{G} \cos \aleph - u' \sin \mathcal{G}' \cos(\omega + \aleph).
\end{aligned}$$

Now, since for the moment under consideration, $r_1 = r_2 = r_3 = r_4 = r$, from this one obtains

$$\begin{aligned}
r \left(\frac{d\mathcal{G}_1}{dt} - \frac{d\mathcal{G}_2}{dt} - \frac{d\mathcal{G}_3}{dt} + \frac{d\mathcal{G}_4}{dt} \right) &= -4u' \sin \mathcal{G}' \cos \omega \\
r \left(\frac{d\mathcal{G}_1}{dt} + \frac{d\mathcal{G}_2}{dt} + \frac{d\mathcal{G}_3}{dt} + \frac{d\mathcal{G}_4}{dt} \right) &= -4v \sin \eta \cos \aleph;
\end{aligned}$$

further:

$$\begin{aligned}
r \left(\frac{d\mathcal{G}'_1}{dt} - \frac{d\mathcal{G}'_2}{dt} + \frac{d\mathcal{G}'_3}{dt} - \frac{d\mathcal{G}'_4}{dt} \right) &= +4u \sin \mathcal{G} \cos \omega \\
r \left(\frac{d\mathcal{G}'_1}{dt} + \frac{d\mathcal{G}'_2}{dt} - \frac{d\mathcal{G}'_3}{dt} - \frac{d\mathcal{G}'_4}{dt} \right) &= 0,
\end{aligned}$$

finally:

$$\begin{aligned}
r \left(\frac{d\eta_1}{dt} + \frac{d\eta_2}{dt} - \frac{d\eta_3}{dt} - \frac{d\eta_4}{dt} \right) &= 0 \\
r \left(\frac{d\eta_1}{dt} - \frac{d\eta_2}{dt} + \frac{d\eta_3}{dt} - \frac{d\eta_4}{dt} \right) &= +4u \sin \mathcal{G} \cos \aleph.
\end{aligned}$$

If one substitutes these values into the aggregates of the second differential coefficients given above, then one obtains

$$r \left(\frac{d^2 r_1}{dt^2} + \frac{d^2 r_2}{dt^2} - \frac{d^2 r_3}{dt^2} - \frac{d^2 r_4}{dt^2} \right) = -8uu' \sin \vartheta \sin \vartheta' \cos \omega$$

$$r \left(\frac{d^2 r_1}{dt^2} - \frac{d^2 r_2}{dt^2} + \frac{d^2 r_3}{dt^2} - \frac{d^2 r_4}{dt^2} \right) = -8uv \sin \vartheta \sin \eta \cos \aleph - 4r \cos \vartheta \cdot \frac{du}{dt}.$$

These values, finally, yield the *sum* of the forces which act on the *positive* and *negative* electricity in element α' ,

$$-\frac{\alpha\alpha'}{r^2} \cdot aeu \cdot ae'u' \left(\sin \vartheta \sin \vartheta' \cos \omega - \frac{1}{2} \cos \vartheta \cos \vartheta' \right),$$

viz., the electrodynamic force acting on the ponderable element α' is determined for moving conductors and variable current intensities, as well as for conductors at rest and constant current intensities, and Ampère's law finds general application with regard to these forces for given positions of the current elements and given current intensities. The application of this law only requires that the current intensities *for each individual moment* be given, with inclusion of the portion added as a result of *induction*.

The *difference* of the forces acting on the *positive* and *negative* electricity in element α' results in the same way,

$$-\frac{\alpha\alpha'}{r^2} \cdot aeu \cdot ae'u' \left(\sin \vartheta \sin \eta \cos \aleph - \frac{1}{2} \cos \vartheta \cos \eta \right) - \frac{1}{2} \frac{\alpha\alpha'}{r} a^2 ee' \cos \vartheta \cdot \frac{du}{dt},$$

or, since, in accordance with page 94,⁶⁷ $aeu = i$, and, because u is variable, $ae \cdot du = di$,

$$= -\frac{\alpha\alpha'}{r^2} i \left(\sin \vartheta \sin \eta \cos \aleph - \frac{1}{2} \cos \vartheta \cos \eta \right) \cdot ae'v - \frac{1}{2} \frac{\alpha\alpha'}{r} ae' \cos \vartheta \cdot \frac{di}{dt}.$$

Now, the force determined in this way seeks to separate the *positive* and *negative* electricity in the induced element α' in the direction of straight line r . The separation cannot succeed in this direction, but only in the direction of the induced element α' itself, which makes the angle ϑ' with the extended straight line r . If, therefore, one resolves that entire force in this direction, viz., if one multiplies the above value by $\cos \vartheta'$, then one obtains the force which actually brings about the separation,

$$= -\frac{\alpha\alpha'}{r^2} i \left(\sin \vartheta \sin \eta \cos \aleph - \frac{1}{2} \cos \vartheta \cos \eta \right) \cdot ae'v \cos \vartheta' - \frac{1}{2} \frac{\alpha\alpha'}{r} ae' \cos \vartheta \cos \vartheta' \cdot \frac{di}{dt}.$$

If this value is divided by e' , then the result is the *electromotor* force, in the usual sense (see Section 24, page 109),⁶⁸ exerted by the inducing element α on the induced element α'

$$= -\frac{\alpha\alpha'}{r^2} i \left(\sin \vartheta \sin \eta \cos \aleph - \frac{1}{2} \cos \vartheta \cos \eta \right) \cdot av \cos \vartheta' - \frac{1}{2} \frac{\alpha\alpha'}{r} a \cos \vartheta \cos \vartheta' \frac{di}{dt}.$$

If the change in the current intensity is made

$$\frac{di}{dt} = 0,$$

then once more we find the same law which was found in Section 24 for the induction of a *constant* current element on the *moving* element of a conductor, and then the *electromotor* force is

⁶⁷ [N. E.] Page 152 of Weber's *Werke*, Vol. 3.

⁶⁸ [N. E.] Page 170 of Weber's *Werke*, Vol. 3.

$$= -\frac{\alpha\alpha'}{r^2}i\left(\sin\vartheta\sin\eta\cos\aleph - \frac{1}{2}\cos\vartheta\cos\eta\right)\cdot av\cos\vartheta',$$

in which the same angles, which were denoted ϑ' , ω , φ in Section 24, are named η , \aleph and ϑ' , and the velocity, which was called u' , is denoted v .

On the other hand, if, in the general value, one makes

$$v = 0,$$

one obtains the same law which was found in Section 28 for the induction of a *variable* current element on the element of a conductor *at rest*, and then the *electromotor* force is

$$= -\frac{1}{2}\frac{\alpha\alpha'}{r}a\cos\vartheta\cos\vartheta'\cdot\frac{di}{dt}.$$

The electromotor force of a *variable* current element on the *moving* element of a conductor is therefore the sum of the electromotor forces which would take place, 1) if the element of the conductor were *not in motion* at the moment under consideration, 2) when the element of the conductor were indeed in motion, but the *current intensity* of the inducing element at the moment under consideration were *unchanged*.

The general law of determining the effects of *arbitrarily moving* conductors with a current flowing through them *according to the galvanic laws*, is herewith completely given, if it may be assumed, that all electrical motions in linear conductors comprised under the name *galvanic currents*, actually conform precisely to the determinations given on page 83 and page 85.⁶⁹ However, even if it is not to be doubted that all *galvanic currents* come close to those determinations, small deviations can nevertheless rightly be expected, given the great dissimilarity in the *sources of galvanism*. These deviations and their influence on the *electrodynamic determination of measure* will be further discussed here.

According to the determinations given on page 83 and page 85,⁷⁰ each current element should contain the *same amount* of positive and negative electricity, and both should flow through the element with *the same velocity*, but in opposite directions. If a *constant* current were to consist of nothing but such elements, whose respective positions remained unchanged, then they would mutually exert no *electromotor* force whatever on each other. See Section 24, page 107.⁷¹ The *electromotor* forces, which would overcome the resistance of the individual elements, and would thereby, according to page 84,⁷² bring about the continuation of the current in all elements simultaneously, would then have to exist *independently of the current elements*, and would be distributed on all current elements in proportion to their resistance, if the current is to uniformly continue to exist in all elements.

Depending on the nature of the *sources of galvanism* generating the *original* electromotor forces, which are independent of the interaction of the current elements themselves, that equal relation between the forces and the resistance to be overcome by them in all elements of the conductor will sometimes occur, sometimes not. Serving an example of the first case, is a homogeneous, circularly shaped conductor, in which a galvanic current is induced by the motion of a magnet in the normal passing through the center of the circle to the plane of the circle. In this case an *electromotor* force acting uniformly on all the elements of the circle would be obtained by means of *magneto-induction*, and, since the *resistance* is likewise the same for all elements, the conditions are hereby fulfilled for the uniform presence of the current in all segments. Given the nature of things, however, such a case seldom occurs; as a rule, no equal relation between the *original* electromotor forces and the *resistance* in all the elements will occur, and the inequalities

⁶⁹ [N. E.] Pages 135 and 139 of Weber's *Werke*, Vol. 3.

⁷⁰ [N. E.] Pages 135 and 139 of Weber's *Werke*, Vol. 3.

⁷¹ [N. E.] Page 168 of Weber's *Werke*, Vol. 3.

⁷² [N. E.] Page 136 of Weber's *Werke*, Vol. 3.

must then be equalized by means of the *interaction* of the elements. Now, if such an interaction of the elements of a constant current, an interaction consisting of electromotor forces, is not to be excluded, then the definition of galvanic currents must be broadened.

By a *galvanic current*, as opposed to other electrical motions not comprised under this name, should be understood a motion of the electricity in a closed conductor, such that the same amounts of positive and negative electricity flow through all its cross-sections simultaneously in the opposite directions. This equality of the positive and negative electricity *flowing through* does not necessarily presuppose the equality of the *moving* positive and negative masses, which was previously assumed, but rather, it can exist even when the latter are of unequal magnitudes, if the *larger* mass flows *slower*, the *smaller* one *faster*. In a galvanic current of the latter kind, *new* electromotor forces arise from the interaction of the elements, by means of which forces the unequal relationship of the *original* electromotor forces can be equalized. For as soon as the *positive* amount of electricity in an element is not equal to the *negative*, viz., as soon as the element, because of an excess of one electricity, is charged with *free electricity*, this *free electricity* itself, *in accordance with the laws of the excitation of electricity by means of separation*, becomes a source of *electromotor* forces for all other elements, which, through intensifying that charge, can be increased such that, added to the *original* electromotor forces, they become proportional to the resistance in all elements, for which, in the galvanic circuits with which we are familiar, a very low degree of electrical charge suffices.

The investigation of how this charge in the individual elements in a closed galvanic circuit *arises* spontaneously in virtue of the initial inequality of the current in the different parts of the circuit, and increases until the given condition of a current uniform in all parts of the circuit is satisfied, leads to the *internal mechanics of the galvanic circuit* and is outside the scope of this Treatise, because there the action of electrical masses on *adjacent* masses must be taken into calculation, while here, merely the actions exerted *at a distance* need be considered. Independently of the investigation of the generation of these charges, and the resulting laws of their strength and distribution, here we will only discuss the influence which they have, *when they are present*, on the electrodynamic determinations of measure. The discussion of this influence is important in this connection, because the presence of such charges is to be viewed as a rule having only infrequent exceptions. Even if this influence is so slight that, even without taking it into consideration, the calculation accords with empirical experience in most cases, nevertheless, it can be useful to know what this influence consists of and how it can become appreciable.

Under the conditions stated on page 128,⁷³ think of the *positive* mass $+ \alpha e$ in the element α as increased by $m \alpha e$, where m denotes a small fraction, while the velocity $+u$ of this mass, however, is thought of as decreasing by the small magnitude $+mu$; likewise think of the *positive* mass $+ \alpha' e$ as increased by $n \alpha' e$, its velocity $+u'$ as decreased by nu' . The forces acting on both electrical masses in element α' are to be determined, which come about through these changes.

The two forces which the *positive* mass $+ \alpha e$ in element α exerted on the *positive* and *negative* masses $+ \alpha' e$ and $- \alpha' e$ in element α' , were

$$+ \frac{\alpha e \cdot \alpha' e'}{r^2} \left(1 - \frac{a^2}{16} \frac{dr_1^2}{dt^2} + \frac{a^2}{8} r \frac{d^2 r_1}{dt^2} \right) \\ - \frac{\alpha e \cdot \alpha' e'}{r^2} \left(1 - \frac{a^2}{16} \frac{dr_3^2}{dt^2} + \frac{a^2}{8} r \frac{d^2 r_3}{dt^2} \right),$$

in which, in accordance with page 129,⁷⁴ we are to make

⁷³ [N. E.] Page 196 of Weber's *Werke*, Vol. 3.

⁷⁴ [N. E.] Page 198 of Weber's *Werke*, Vol. 3.

$$\frac{dr_1}{dt} = -u \cos \vartheta + u' \cos \vartheta' + v \cos \eta$$

$$\frac{dr_3}{dt} = -u \cos \vartheta - u' \cos \vartheta' + v \cos \eta,$$

and, in accordance with page 129 and page 131:⁷⁵

$$r \frac{d^2 r_1}{dt^2} = +u^2 \sin^2 \vartheta + u'^2 \sin^2 \vartheta' + v^2 \sin^2 \eta$$

$$- 2(uu' \sin \vartheta \sin \vartheta' \cos \omega + uv \sin \vartheta \sin \eta \cos \aleph - u'v \sin \vartheta' \sin \eta \cos(\omega + \aleph))$$

$$- r \left(\cos \vartheta \frac{du}{dt} - \cos \vartheta' \frac{du'}{dt} - \cos \eta \frac{dv}{dt} \right)$$

$$r \frac{d^2 r_3}{dt^2} = +u^2 \sin^2 \vartheta + u'^2 \sin^2 \vartheta' + v^2 \sin^2 \eta$$

$$+ 2(uu' \sin \vartheta \sin \vartheta' \cos \omega - uv \sin \vartheta \sin \eta \cos \aleph - u'v \sin \vartheta' \sin \eta \cos(\omega + \aleph))$$

$$- r \left(\cos \vartheta \frac{du}{dt} + \cos \vartheta' \frac{du'}{dt} - \cos \eta \frac{dv}{dt} \right).$$

The *Difference* between the above two forces, on which the *electromotor* force depends, can be made

$$= 2 \frac{\alpha e \cdot \alpha' e'}{r^2},$$

because the remaining terms are very small in comparison with this first one. Now, if $(1+m)e$ is substituted for e and multiplied by $\cos \vartheta' / e'$, and the original value multiplied by $\cos \vartheta' / e'$ is subtracted, one obtains, in accordance with page 109 and page 133,⁷⁶ the *electromotor* force which arises from the charging of element α with free electricity and which acts on element α'

$$= 2m \frac{\alpha \alpha'}{r^2} e \cos \vartheta'.$$

Charging element α' itself, which is acted upon, does not change the electromotor force; for if, in the above difference, $(1+n)e'$ is substituted for e' and multiplied by $\cos \vartheta' / (1+n)e'$, and the original value multiplied by $\cos \vartheta' / e'$ is subtracted, there is no remainder.

The *sum* of the above two forces, on which the *electrodynamical* force acting on the ponderable carrier depends, is obtained by substitution of the values arrived at

$$= -\frac{1}{2} \frac{\alpha \alpha'}{r^2} \cdot \alpha e \cdot \alpha' e' [uu' \sin \vartheta \sin \vartheta' \cos \omega - u'v \sin \vartheta \sin \eta \cos(\omega + \aleph)$$

$$- \frac{1}{2} uu' \cos \vartheta \cos \vartheta' + \frac{1}{2} u'v \cos \vartheta' \cos \eta - \frac{1}{4} r \cos \vartheta' \cdot \frac{du}{dt}].$$

From this is obtained 1) the portion arising from the increase in the mass $+ \alpha e$, of the force with which the elements α and α' repel each other, when $(1+m)e$ is substituted for e , and the original value is subtracted,

⁷⁵ [N. E.] Pages 198 and 200 of Weber's *Werke*, Vol. 3.

⁷⁶ [N. E.] Pages 170 and 202 of Weber's *Werke*, Vol. 3.

$$= -\frac{m}{2} \frac{\alpha\alpha'}{r^2} \cdot ae \cdot ae' \left[uu' \sin \vartheta \sin \vartheta' \cos \omega - u'v \sin \vartheta' \sin \eta \cos(\omega + \aleph) \right. \\ \left. - \frac{1}{2} uu' \cos \vartheta \cos \vartheta' + u'v \cos \vartheta' \cos \eta - \frac{1}{4} r \cos \vartheta' \frac{du}{dt} \right];$$

2) the portion of the force arising from the decrease in velocity $+u$, when $(1-m)u$ is substituted for u , and the original value is subtracted,

$$= +\frac{m}{2} \frac{\alpha\alpha'}{r^2} \cdot ae \cdot ae' \left[uu' \sin \vartheta \sin \vartheta' \cos \omega - \frac{1}{2} uu' \cos \vartheta \cos \vartheta' \right];$$

3) the portion of the force arising from the increase in the mass $+\alpha'e'$, when $(1+n)e'$ is substituted for e' , and the original value is subtracted,

$$= -\frac{n}{2} \frac{\alpha\alpha'}{r^2} \cdot ae \cdot ae' \left[uu' \sin \vartheta \sin \vartheta' \cos \omega - u'v \sin \vartheta' \sin \eta \cos(\omega + \aleph) \right. \\ \left. - \frac{1}{2} uu' \cos \vartheta \cos \vartheta' + \frac{1}{2} u'v \cos \vartheta' \cos \eta - \frac{1}{4} r \cos \vartheta' \frac{du'}{dt} \right];$$

4) the portion of the force arising from the decrease in the velocity $+u'$, when $(1-n)u'$ is substituted for u' , and the original value is subtracted,

$$= +\frac{n}{2} \frac{\alpha\alpha'}{r^2} \cdot ae \cdot ae' \left[uu' \sin \vartheta \sin \vartheta' \cos \omega - u'v \sin \vartheta' \sin \eta' \cos(\omega + \aleph) \right. \\ \left. - \frac{1}{2} uu' \cos \vartheta \cos \vartheta' + \frac{1}{2} u'v \cos \vartheta' \cos \eta \right].$$

If all these portions which arise are conjoined, one obtains the influence which the charging of elements α and α' with free *positive* electricity (if m and n have positive values) or *negative* electricity (if m and n have negative values) has on the *electrodynamic* repulsive force which α and α' exert; to be precise, it is the resulting increase in this repulsive force, when one makes $ae v = \chi$, $ae' u' = i'$ and $ae' du' = di'$,

$$= +\frac{m}{2} \frac{\alpha\alpha'}{r^2} \chi i' \left(\sin \vartheta' \sin \eta \cos(\omega + \aleph) - \frac{1}{2} \cos \vartheta' \cos \eta \right) + \frac{m+n}{8} \frac{\alpha\alpha'}{r} ae \cos \vartheta' \frac{di'}{dt}.$$

This influence, therefore, wholly vanishes, when the action on a *constant* current element *at rest* is considered, for which $v = 0$ and $di' = 0$. Further, this influence also vanishes in a *constant* current element *in motion* α' , when the element α acting upon it possesses no free electricity, because in that case $m = 0$ and $di' = 0$. Finally, if free electricity is present in element α , there exists that influence in a force which is equal to that force which would be exerted on current element α' by another current element in the place of α , when the masses contained in it, $+\frac{1}{2} m \alpha e$ and

$-\frac{1}{2} \alpha e$ were to flow with velocities $-v$ and $+v$ in the direction in which current element α' is moved with velocity $+v$. The necessity of this influence can also be examined from Fechner's viewpoint in Section 16, page 116.⁷⁷ For the case where a change occurs in current intensity i' in current element α' , which is acted upon, there is added to the above, finally, an influence proportional to this change di' , and with the sum of the free electricity present in both elements α and α' , which determines the last term in the formula.

⁷⁷ [N. E.] Page 179 of Weber's *Werke*, Vol. 3.

In the method for determining galvanic current given in Section 19, on which the law describing two electrical masses acting on one another at a distance is based, instead of the *actual* current, in which the velocity of the flowing electricity probably fluctuates in its passage from one ponderable particle to the other in a steady alternation, an *ideal* current of *uniform* velocity is assumed. This substitution was necessary to simplify the treatment, and it seems permissible because it is simply a question of an action *at a distance*. It now remains to prove this initial assumption about the electrical law.

Let there be two electrical masses, e and e' , which at the end of time t are found at a distance r from one another. Let their relative velocity up to this instant be a constant $= \gamma$. The repulsive force of the two masses in the last moment of the given time period t , would thus be, according to the fundamental electrical law:

$$\frac{ee'}{r^2} \left(1 - \frac{a^2}{16} \gamma^2 \right).$$

In the following element of time, ε , an acceleration

$$\frac{d^2r}{dt^2} = \alpha$$

occurs, whereby the repulsive force for the duration of the time period will be

$$= \frac{ee'}{r^2} \left(1 - \frac{a^2}{16} \gamma^2 \right) + \frac{a^2}{8} \cdot \frac{ee'}{r} \alpha.$$

We now multiply the increase in force, which has occurred from the previous moment to the present one, by the time element ε itself. We thus obtain, as the amount by which the repulsive action has grown by this acceleration over the path dr , in which the masses e and e' have distanced themselves in the time ε ,

$$= \frac{a^2}{8} \cdot \frac{ee'}{r} \cdot \alpha \varepsilon.$$

The relative velocity of the two masses, which before the time element ε was $= \gamma$ is then, after this time element,

$$= \gamma + \alpha \varepsilon.$$

Let this now remain unchanged, then the repulsive force of the two masses, when they have arrived at the distance ρ ,

$$= \frac{ee'}{\rho^2} \left(1 - \frac{a^2}{16} (\gamma + \alpha \varepsilon)^2 \right),$$

whereby, when $\alpha \varepsilon$ is very small in comparison to γ , it becomes

$$= \frac{ee'}{\rho^2} \left(1 - \frac{a^2}{16} \gamma^2 - \frac{a^2}{8} \alpha \gamma \varepsilon \right).$$

Multiplying this expression by the time

$$\frac{d\rho}{\gamma + \alpha \varepsilon},$$

in which both masses have distanced themselves from one another by the line element $d\rho$, and integrating between the limits $\rho = r$ to $\rho = r_1$, we get the repulsive action of the two masses over the distance $r_1 - r$, as

$$= \frac{ee'}{\gamma + \alpha\varepsilon} \left(1 - \frac{a^2}{16} \gamma^2 - \frac{a^2}{8} \alpha\gamma\varepsilon \right) \left(\frac{1}{r} - \frac{1}{r_1} \right).$$

Finally at the instant when the two masses are at the distance r_1 , a deceleration

$$\frac{d^2r}{dt^2} = -\alpha$$

occurs, which just as the earlier acceleration lasted only during the time element ε , so now the relative velocity of the two masses again returns to its original value

$$= \gamma,$$

and in the path traveled in the time element ε there takes place a decrease in the repulsive action

$$= -\frac{a^2}{8} \cdot \frac{ee'}{r_1} \cdot \alpha\varepsilon.$$

One then gets as the sum of the repulsive action over the entire path $r_1 - r$, including the time elements ε , in which both the acceleration and deceleration took place,

$$= +\frac{a^2}{8} \frac{ee'}{r} \alpha\varepsilon + \frac{ee'}{\gamma + \alpha\varepsilon} \left(1 - \frac{a^2}{16} \gamma^2 - \frac{a^2}{8} \alpha\gamma\varepsilon \right) \left(\frac{1}{r} - \frac{1}{r_1} \right) - \frac{a^2}{8} \cdot \frac{ee'}{r_1} \alpha\varepsilon,$$

or, when $\alpha\varepsilon$ is very small in comparison to γ ,

$$= \frac{ee'}{\gamma + \alpha\varepsilon} \left(1 - \frac{a^2}{16} \gamma^2 \right) \left(\frac{1}{r} - \frac{1}{r_1} \right).$$

The time for which this sum applies is, however

$$= \frac{r_1 - r}{\gamma + \alpha\varepsilon}.$$

If one divides the sum by this time, the average repulsive force during this time is obtained:

$$= \frac{ee'}{rr_1} \left(1 - \frac{a^2}{16} \gamma^2 \right),$$

that is, the same value as would occur if the path $r_1 - r$ had been traversed at the original velocity γ . It thus follows that if the relative velocity of two electrical masses, arriving successively at two different distances of separation is the same, their average repulsive force over the time interval is the same as the average repulsive force which they would have achieved, if they had traveled with the initial relative velocity from the first distance to the latter.

This theorem may now be applied to the proof of the above assumption. For, when a particle of electricity moves in a galvanic current from one ponderable molecule to another, it will arrive in places both before and behind the molecule, where its velocity is the same as that of another electrical particle moving in another current. The average repulsive force of both particles for the duration of the passage of the first particle out of the first position into the next, is then the same, as it would have been if both particles had moved through the space with their initial relative velocities, that is, as if no change had taken place in the velocity of the electricity flowing from one molecule of the ponderable conductor to the other.

Besides the change in velocity of the electrical particles as they move from one molecule of the ponderable conductor to the next, we must also consider the changes of direction by which approaching particles avoid one other. One easily sees that within the measurable distances of the current element under consideration, no significant variation in the distances would occur, and accordingly only periodic variations in the relative velocity produced by these changes of direction would remain, which variations have already been included in the foregoing.

It stands to reason, that in place of a current in which the velocity and direction of the flowing electricity are subjected to a periodic change, a *uniform* current can rightfully be substituted, as is done in Section 19.

It is also permitted, that, in place of a straight current element, a bent one be substituted, so long as the beginning and end points remain unaltered, and no perceptible difference from the straight line joining them is allowed. Finally, as happens in Article 29, in place of one element, three elements may be considered, which behave in respect to the one like the edges of a parallelepiped to its diagonal.

32.

The discovered fundamental electrical law can be expressed in different ways, which will be illustrated by a few examples.

1) Because distance r is always a positive magnitude, it can be written as ρ^2 . This yields⁷⁸

$$dr = 2\rho d\rho, \quad d^2r = 2\rho d^2\rho + 2d\rho^2$$

hence⁷⁹

$$r = \rho^2, \quad \frac{dr^2}{dt^2} = 4\rho^4 \frac{d\rho^2}{dt^2}, \quad \frac{d^2r}{dt^2} = 2\rho \frac{d^2\rho}{dt^2} + 2\frac{d\rho^2}{dt^2}.$$

If these values are substituted in the formula $\frac{ee'}{r^2} \left(1 - \frac{a^2}{16} \frac{dr^2}{dt^2} + \frac{a^2}{8} r \frac{d^2r}{dt^2} \right)$, the following *shorter* formula is obtained:

$$\frac{ee'}{\rho^4} \left(1 + \frac{a^4}{4} \rho^3 \frac{d^2\rho}{dt^2} \right).$$

2) By *reduced relative velocity* of the masses e and e' should be understood that relative velocity, which those masses, reaching at the end of time t the distance r , the relative velocity dr/dt , and the relative acceleration d^2r/dt^2 , would possess, *if the last-named were constant*, at the moment $(t - \mathcal{G})$, at which both, according to this premise, would meet at one point. If v denotes this *reduced relative velocity*, then according to the well-known law of *uniform acceleration*:

$$\frac{dr}{dt} - v = \frac{d^2r}{dt^2} \cdot \mathcal{G}$$

$$r = v\mathcal{G} + \frac{1}{2} \frac{d^2r}{dt^2} \cdot \mathcal{G}^2.$$

By elimination of \mathcal{G} , these two equations yield:

$$\frac{1}{2}v^2 = \frac{1}{2} \frac{dr^2}{dt^2} - r \frac{d^2r}{dt^2}.$$

If these values are substituted in the formula $\frac{ee'}{r^2} \left(1 - \frac{a^2}{16} \frac{dr^2}{dt^2} + \frac{a^2}{8} r \frac{d^2r}{dt^2} \right)$ the following *shorter* formula is obtained:

⁷⁸ [N. E.] The last equation should be understood as $d^2r = 2\rho d^2\rho + 2(d\rho)^2$.

⁷⁹ [N. E.] These equations should be understood as $r = \rho^2$, $\left(\frac{dr}{dt}\right)^2 = 4\rho^2 \left(\frac{d\rho}{dt}\right)^2$, $\frac{d^2r}{dt^2} = 2\rho \frac{d^2\rho}{dt^2} + 2\left(\frac{d\rho}{dt}\right)^2$.

$$\frac{ee'}{r^2} \left(1 - \frac{a^2}{16} v^2 \right),$$

which can be verbally expressed in the following way: *The decrease, caused by the motion, in the force with which two electrical masses would act upon each other, if they were not in motion, is proportional to the square of their reduced relative velocity.*

3) If $\frac{ee'}{r^2} \left(1 - \frac{a^2}{16} \frac{dr^2}{dt^2} + \frac{a^2}{8} r \frac{d^2r}{dt^2} \right)$ is the *absolute force* with which the mass e acts on and repels the mass e' , and conversely, e' acts on and repels e , then there follows from this the *accelerative force* for mass e ⁸⁰

$$= \frac{e'}{r^2} \left(1 - \frac{a^2}{16} \frac{dr^2}{dt^2} + \frac{a^2}{8} r \frac{d^2r}{dt^2} \right),$$

for mass e' ,

$$= \frac{e}{r^2} \left(1 - \frac{a^2}{16} \frac{dr^2}{dt^2} + \frac{a^2}{8} r \frac{d^2r}{dt^2} \right).$$

The following *relative acceleration* results for both masses:

$$= \frac{e+e'}{r^2} \left(1 - \frac{a^2}{16} \frac{dr^2}{dt^2} + \frac{a^2}{8} r \frac{d^2r}{dt^2} \right).$$

If to this is added that *relative acceleration* which results for the same masses, partly from the persistence of their motion in their present trajectories, partly from the influence of other bodies, which would be conjointly denoted as f , then the following equation is obtained for the *total relative acceleration*, i.e., for d^2r/dt^2 :

$$\frac{d^2r}{dt^2} = \frac{e+e'}{r^2} \left(1 - \frac{a^2}{16} \frac{dr^2}{dt^2} + \frac{a^2}{8} r \frac{d^2r}{dt^2} \right) + f.$$

With the help of this equation, the differential coefficient d^2r/dt^2 can be determined and its value put into the formula $\frac{ee'}{r^2} \left(1 - \frac{a^2}{16} \frac{dr^2}{dt^2} + \frac{a^2}{8} r \frac{d^2r}{dt^2} \right)$, which then becomes the following expression, representing the force with which two electrical masses act upon each other, independent of their *relative acceleration*.⁸¹

⁸⁰ [N. E.] What Weber calls here the *accelerative force for mass e* (beschleunigende Kraft für die Masse e) is the acceleration of the particle with charge e relative to an inertial system of reference when we suppose a system of units for which the inertial mass of this particle is equal to e . In his sixth major Memoir published in 1871, which has already been translated to English (W. Weber, *Philosophical Magazine*, Vol. 42, pp. 1-20 and 119-149 (1872), "Electrodynamic measurements – Sixth Memoir, relating specially to the principle of the conservation of energy"), Weber generalizes this result considering the inertial masses of the particles with charges e and e' as given by, respectively, ε and ε' . In this case he was considering a system of units for which the unit of mass is one milligram; see especially pages 2 and 3 of this English translation of 1872. In this case the acceleration of the particle with charge e would be given by, according to Newton's second law of motion: $a = \frac{ee'}{\varepsilon r^2} \left(1 - \frac{a^2}{16} \frac{dr^2}{dt^2} + \frac{a^2}{8} r \frac{d^2r}{dt^2} \right)$. By the same reasoning the

acceleration a' of the particle with charge e' would be given by $a' = \frac{ee'}{\varepsilon' r^2} \left(1 - \frac{a^2}{16} \frac{dr^2}{dt^2} + \frac{a^2}{8} r \frac{d^2r}{dt^2} \right)$.

⁸¹ [N. E.] In the paper of 1871 quoted above, this expression takes the following more generalized form (see pages 3, 4 and 147 of W. Weber, *Philosophical Magazine*, Vol. 43, pp. 1-20 and 119-149 (1872), "Electrodynamic measurements – Sixth Memoir, relating specially to the principle of the conservation of energy"):

$$\frac{ee'}{r^2 - \frac{a^2}{8}(e+e')r} \cdot \left(1 - \frac{a^2}{16} \frac{dr^2}{dt^2} + \frac{a^2}{8} rf\right).$$

Accordingly, this force depends on the magnitude of the masses, on their distance, on their relative velocity, and, finally, on that relative acceleration f , which it reaches partly as a result of the persistence of its already existing motion, partly as a result of the forces acting on it from *other bodies*.

It seems to follow from this, that the *direct interaction of two electrical masses* would not exclusively depend on these masses themselves and their relations to one another, but would also depend on the presence of *third* bodies. Now, it is well known that Berzelius has already supposed the possibility of the *dependency of the direct interaction of two bodies on the presence of a third*, and has given the name *catalytic* to the forces resulting from this. If we avail ourselves of this name, then it can be said hereafter that the *electrical phenomena* also originate in part from *catalytic forces*.

This demonstration of *catalytic* forces for *electricity* is, however, no *strict* inference from the discovered fundamental electrical law. That would be the case only if one necessarily had to associate this fundamental law with the *idea* that only such forces would thereby be determined which electrical masses *directly* exerted upon one another at a distance. It is, however, possible to *conceive* that the forces included under the discovered fundamental law are also the kind of forces which two electrical masses *indirectly* exert upon one another, and which hence must depend, *first of all* upon the *transmitting medium*, and *further* upon all *bodies, which act on this medium*. It can easily occur, that such *indirectly* exerted forces, when the transmitting medium evades our observation, *appear as catalytic forces*, although they are not. In order to speak of *catalytic* forces in such cases, the concept of *catalytic* force would have to be fundamentally modified. That is, by *catalytic* force one would have to understand the kind of *indirectly* exerted force, which can be determined by a *general rule*, by means of a positive knowledge of the bodies to whose influence the *transmitting* medium is subjected, without knowledge, however, of this *medium itself*. The discovered fundamental electrical law yields a general rule for determination of *catalytic* forces in this sense.

Another still undecided question is, however, whether the knowledge of the *transmitting* medium, even if it is not necessary for the determination of forces, would nevertheless be *useful*. That is, the general rule for determination of forces could perhaps be expressed still more *simply*, when the transmitting medium were taken into consideration, than was otherwise possible in the *fundamental electrical law presented here*. However, *investigation of the transmitting medium*, which perhaps would elucidate many other things as well, is itself necessary in order to decide this question.

The *idea of the existence* of such a transmitting medium is already found in the *idea of the all-pervasive neutral electrical fluid*, and even if this *neutral fluid*, apart from conductors, has up to

$$\frac{ee'}{rr - \frac{2r}{cc} \cdot \frac{\varepsilon + \varepsilon'}{\varepsilon\varepsilon'} ee'} \cdot \left(1 - \frac{1}{cc} \frac{dr^2}{dt^2} + \frac{2rf}{cc}\right).$$

In this equation e and e' are the charges of the particles with inertial masses

ε and ε' , and Weber replaced $4/a$ by c . This constant c had already been measured by Weber and Kohlrausch in 1854-5, who found it as $439450 \times 10^6 \text{ mm/s}$. That is, it is essentially $\sqrt{2}$ times light velocity in vacuum. It should not be confused with the present day constant c , which is equal to the light velocity in vacuum. There is an English translation of a paper by Weber and Kohlrausch describing this fundamental measurement which they were the first to perform: W. Weber and R. Kohlrausch, "On the amount of electricity which flows through the cross-section of the circuit in galvanic currents," In: F. Bevilacqua and E. A. Gianetto, editors, *Volta and the History of Electricity*, pp. 287-297 (Università degli Studi di Pavia and Editore Ulrico Hoepli, Milano, 2003).

now almost entirely evaded the physicists' observations, nevertheless there is now hope that we can succeed in gaining more direct elucidation of this all-pervasive fluid in several new ways. Perhaps in other bodies, apart from conductors, no currents appear, but only *vibrations*, which can be observed more precisely for the first time with the methods discussed in Section 16. Further, I need only recall Faraday's latest discovery of the influence of *electrical currents on light vibrations*, which make it not improbable, that the all-pervasive neutral electrical medium is itself that all-pervasive ether, which creates and propagates light vibrations, or that at least the two are so intimately interconnected, that observations of light vibrations may be able to explain the behavior of the neutral electrical medium.

Ampère has already called attention to the possibility of an *indirect* action of electrical masses on each other, as cited in the introduction on page 3,⁸² “namely, according to which, the *electrodynamic phenomena*” would be ascribed “to the *motions communicated to the ether* by electrical currents.” Ampère himself, however, pronounced the examination of this possibility an extraordinarily difficult investigation, which he would have no time to undertake.

If, in addition, new empirical data, such as, for example, those which will perhaps emerge from further pursuit of the experiments to be carried out in accordance with Section 16 on *electrical vibrations*, and from Faraday's discovery, should appear to be particularly appropriate for gradually eliminating the difficulties not overcome by Ampère, then the fundamental electrical law in the form given here, independent of the transmitting medium, may afford a not insignificant basis for expressing this law in other forms, dependent upon the transmitting medium.

⁸² [N. E.] Page 30 of Weber's *Werke*, Vol. 3.

Errata of the paper by W. Weber, “Determinations of electrodynamic measure: concerning a universal law of electrical action”, English translation by S. P. Johnson, edited by L. Hecht and A. K. T. Assis, available through the magazine 21st Century Science and Technology, 146 pages in PDF, posted in March, 2007: <http://21sci-tech.com/translation.html> and <https://www.ifi.unicamp.br/~assis>

- Page 3, line 23 should read:
 motions imparted to the ether by the electrical currents, could lead to the same formula.”

- Page 19, lines 28 and 29 should read:
 72.589
 36.786,

- Page 27, line 17 should read:

400	510.04			561.90		
-----	--------	--	--	--------	--	--

- Page 27, line 25 should read:

		79.45			298.81	
--	--	-------	--	--	--------	--

- Page 27, line 40 should read:

westerly		192.02	192.17		297.99	297.81
----------	--	--------	--------	--	--------	--------

- Page 28, line 17 should read:

300	433.35			265.02		
-----	--------	--	--	--------	--	--

- Page 28, line 18 should read:

easterly		190.23	190.08		296.98	297.30
----------	--	--------	--------	--	--------	--------

- Page 30, line 13 should read:

	485.70			329.30		
--	--------	--	--	--------	--	--

- Page 35, line 21 should read:

R	v	v'
0.5 m	0°10'12''	0°4'44''

- Page 36, line 13 should read:
 is an expression for the magnitude of the reciprocal action of both elements;
 the direction of this action for both

- Page 39, line 1 should read:

$$\frac{1}{r^5} = \frac{1}{l^5} \left(1 + \frac{5}{2}k \cos \omega + \frac{35}{8}k^2 \cos^2 \omega + \frac{105}{16}k^3 \cos^3 \omega + \frac{1155}{128}k^4 \cos^4 \omega + \dots \right) .$$

- Page 42, line 11 should have α^2 instead of a^2 , namely:

$$A \left(1 - \frac{\alpha^2}{5000} + \frac{\gamma^2}{22000} \right) \cdot \alpha \gamma ,$$

- Page 46, line 9 should read (original German expressions: *nordmagnetische Masse* $+\mu$ and *südmagnetische Masse* $-\mu$):

If, in a steel rod, the north magnetic mass $+\mu$ and the south magnetic mass $-\mu$ are divided at C by line α , which

- Page 46, lines 12 and 13 should read:

α , in which the mass $+\mu$ is thought of as concentrated, and C its midpoint, and δ designates the angle which Cn' forms with the direction CD or DC of the force given above, then $\alpha \sin \delta$ is the distance of the points of action of

- Page 46, line 18 should read:
force given above.

- Page 46, line 20 should read:

From the *electromagnetic law*, the effect of a closed current on the north magnetic mass $+\mu$ of the

- Page 47, there should exist the following expression between lines 7 and 8:

$$\cos AC\sigma' = \sin ACs' = ACs'$$

- Page 48, line 12 should read:

magnetic rod at A , whose magnetic moment is

- Page 51, the equation on line 36 should read:

$$\frac{29314000 \cdot 21327000}{\frac{1}{3}\pi^2 \cdot 55.8^2 \cdot 44.4^3} \cdot \pi^2 i^2 = 180000$$

- Page 54, line 7 of the 5th paragraph should read:

of the induction mediated oscillations, as well as of the decrease of the arc of the oscillations,

- Page 58, line 4 of the first Table should read:

25.	23' 4.39"	28.17"	- 0.23"
-----	-----------	--------	---------

- Page 60, line 4 of the first table should read:

9.	32' 7.03"	464.44	679.15	2.831 966	
----	-----------	--------	--------	-----------	--

- Page 60, line 9 of the first table should read:

74.	49' 16.79"	464.22	292.27	2.465 784	109.10
-----	------------	--------	--------	-----------	--------

- Page 63, the last line should read:

closed up and put into oscillation, while the current of the same voltaic battery was conducted through

- Page 65, line 7 should read:

calculates from the measured arcs of oscillation of our coil and from its periods of oscillation, likewise

- Page 69, the title of Section 14 should read:

14. Repetition of Ampre's fundamental experiment with common electricity, and measurement of the duration of the electrical spark during discharge of a Leyden battery.

- Page 69, line 10 of Section 14 should read:

However, it seems still more important to repeat Ampre's fundamental experiment with *common*

- Page 69, line 12 of Section 14 should read:

wire, since there are such considerable differences between this current of common electricity and all

- Page 69, line 16 of Section 14 should read:

of a current of common electricity, or, given a longer duration, the *discontinuity* of the current might be

- Page 69, lines 21 and 22 of Section 14 should read:

with common electricity, of which I will now give a more precise account here.

It is known, that the repetition of Oersted's fundamental experiment with the *common*

- Page 70, line 1 of the 2nd paragraph should read:

Now, while the main point of performing Oersted's fundamental experiment with common

- Page 70, line 8 of the 4th paragraph should read:

of common electricity passing through, turned out to be like that which was already *predetermined* by

- Page 70, line 10 of the 4th paragraph should read:

made with a current of common electricity.

- Page 70, line 3 of the 5th paragraph should read:

any cases at all, where the current of common electricity would yield Oersted's fundamental

- Page 71, line 1 should read:

experiment, but not Ampre's, or whether with respect to common electricity, both kinds of effects

- Page 72, line 4 below the second table should read:
intensity of the discharge by means of the resistance of these bodies, and to make all the electricity

- Page 73, line 9 of the table should read:

1 000 mm	95.8	210.1	43.7
----------	------	-------	------

- Page 74, line 7 below the third table should read:
discontinuity of the currents of common electricity (which was already discussed above, and which

- Page 80, line 4 should read:
greater range to electrodynamic experiments with common electricity, by rendering dispensable the

- Page 84, lines 17 and 18 should read:
ponderable carrier, by means of which, in an immeasurably short time, it is canceled once more. Through this *resistance*, during the time interval in which this motion is canceled, all forces,

- Page 98, line 24 should read:
to the same values, as are given for this case by the fundamental law of *electrostatics*; for these

- Page 101, the first line of the fourth equation should read:

$$\left(\frac{d^2 r_1}{dt^2} + \frac{d^2 r_2}{dt^2} - \frac{d^2 r_3}{dt^2} - \frac{d^2 r_4}{dt^2} \right) = +u \sin \vartheta \left(\frac{d\vartheta_1}{dt} - \frac{d\vartheta_2}{dt} - \frac{d\vartheta_3}{dt} + \frac{d\vartheta_4}{dt} \right)$$

- Page 103, the last line of the footnote should read:

$$y' - y = r_1 \cos RY .$$

- Page 105, line 2 upwards from the bottom should read:
dependency given by Ohm's law of the current intensity on the electromotive force and the total

- Page 106, line 5 should read:
effects of the above-cited currents, and which move the ponderable conductors themselves.

- Page 106, footnote 45 should read:
[N. E.] See beginning of Section 22.

- Page 107, line 17 should read:
masses, the electrical masses themselves are, however, somewhat displaced in their carriers, and

- Page 109, line 26 should read:

$$= -\frac{\alpha\alpha'}{r^2}i \left(\cos \varepsilon - \frac{3}{2} \cos \vartheta \cos \vartheta' \right) \cdot ae' u' \cos \varphi .$$

- Page 109, the last equation should read:

$$= -\frac{\alpha\alpha'}{r^2}i \left(\cos \varepsilon - \frac{3}{2} \cos \vartheta \cos \vartheta' \right) \cdot au' \cos \varphi .$$

- Page 111, line 24 should read:

element in a direction perpendicular to α' and r . It follows from this the magnitude and direction

- Page 112, lines 1 and 2 should read:

axis and of line r , and the sine of this angle with line r is to $\sin \psi$ as $1 : \sqrt{1 + 3 \cos^2 \psi}$, and finally, if for the sake of brevity, $\frac{1}{r^3} \sqrt{1 + 3 \cos^2 \psi}$ is denoted by \bar{d} ,

- Page 116, line 26 should read:

(neutral) wire $a'b'$ away from the (excited) wire ab at rest, one could do the opposite, and the induction

- Page 117, line 30 should read:

Here, u' and α' are to be written v and ds , in accordance with Neumann's notation; hence the theory

- Page 117, line 32 should read:

$$Eds = -avDds ,$$

- Page 125, line 15 should read:

$\cos \beta = \cos \beta' = 0$; finally, for the 6th and 7th terms, which are proportional to $\alpha_1 \alpha'_1$ and to $\alpha_2 \alpha'_2$,

- Page 125, line 18 should read:

$$\pm \frac{ai}{2} \cdot \frac{\alpha_1 \alpha'_2}{r} \cos \vartheta' \cot \vartheta' \quad \text{and} \quad \pm \frac{ai}{2} \cdot \frac{\alpha_2 \alpha'_1}{r} \cos \vartheta' \cot \vartheta' ,$$

- Page 136, line 26 should read:

$-\frac{1}{2}mae$ were to flow with velocities $-v$ and $+v$ in the direction in which current element α'

- Page 139, line 6 should read:

straight line joining them is allowed. Finally, as happens in Section 29, in place of one element,

- Page 139, line 14 should read:

$$r = \rho^2 , \quad \frac{dr^2}{dt^2} = 4\rho^2 \frac{d\rho^2}{dt^2} , \quad \frac{d^2r}{dt^2} = 2\rho \frac{d^2\rho}{dt^2} + 2 \frac{d\rho^2}{dt^2} .$$